

*Pioneer Dj*

DJ Controller

# DDJ-1000

[pioneerdj.com/support/  
rekordbox.com](http://pioneerdj.com/support/rekordbox.com)

For FAQs and other support information for this product, visit the above site.

Operating Instructions

# Contents

## How to read this manual

- Thank you for purchasing this Pioneer DJ product.  
Be sure to read this manual and the “Operating Instructions (Quick Start Guide)” included with the unit. Both documents include important information that you should understand before using this product.
- In this manual, names of buttons and terminals, menus of this product and your computer, etc., are enclosed in square brackets ([ ]) (e.g. [FILE], [CUE] button, [PHONES] output terminal).
- Screens, external appearance, and software and hardware specifications described in this manual are based on the product that is still under development and may differ from the final specifications.
- Depending on your operating system, the web browser settings, etc., the procedures described in this manual may differ from actual operations.

This manual consists mainly of explanations of functions of this unit as hardware. For detailed instructions on operating the rekordbox software, see the rekordbox Manual.

- The rekordbox Operating Instructions can be downloaded from the following site.  
[rekordbox.com/manual](http://rekordbox.com/manual)

## 01 Before start

Features .....	3
Accessories.....	3
Viewing the rekordbox introduction.....	3
rekordbox.....	3
Installing rekordbox.....	4

## 02 Part names and functions

Top panel of the unit.....	5
Browser section.....	5
Deck sections.....	6
Jog dial display section .....	8
Mixer section .....	8
Rear panel .....	10
Front panel .....	11

## 03 Basic operation

Example of connections.....	12
Starting the system.....	15
Turning off the system.....	16

## 04 Advanced operation

Using 4 beat loops .....	17
Using manual loops .....	17
Using the performance pads.....	17
Using slip mode.....	20
Using the fader start function.....	21
Using effects .....	21
Using the BEAT FX function .....	21
Types of BEAT FX .....	22
Using the SOUND COLOR FX function .....	24
Using a microphone.....	24
Using external inputs .....	25

## 05 Changing the settings

Launching utilities mode.....	26
Changing the settings with rekordbox.....	26
Setting utility software.....	28

## 06 Additional information

Troubleshooting.....	29
Liquid crystal display .....	30
Signal flow .....	31
Using this unit as a controller for other DJ software.....	31
Trademarks and registered trademarks .....	33

# Before start

## Features

This unit is an all-in-one DJ controller designed specifically for rekordbox dj. Its interfaces incorporating various controls such as "BIG JOG", "PERFORMANCE PADS", and "4-CHANNEL MIXER" are positioned with room to spare to allow for more individualistic DJ performances using rekordbox dj. Also, numerous input and output terminals support a variety of DJ styles, and the design makes the unit look high quality, which is appropriate in a variety of scenes such as nightclubs and home parties.

## Accessories

- AC adapter
- Power cord
- USB cable<sup>1)</sup>
- Warranty (for some regions only)<sup>2)</sup>
- Operating Instructions (Quick Start Guide)
- rekordbox dj license key card

<sup>1)</sup> One USB cable is included with this unit.

To connect two units, separately prepare a cable that conforms to the USB 2.0 standard.

<sup>2)</sup> Products for Europe only. (The corresponding information is provided on the back cover of the "Operating Instructions (Quick Start Guide)" for Japan, and on the last page of the English and French versions of the "Operating Instructions (Quick Start Guide)" for the North American region.)

## Cautions

The license key cannot be reissued. Be careful not to lose it.

## Viewing the rekordbox introduction

**1 Launch a web browser on the computer and access the site below.**

[rekordbox.com/manual](http://rekordbox.com/manual)

**2 Click the required language of the rekordbox introduction.**

## rekordbox

- rekordbox  
rekordbox is music management software for DJs to prepare tracks and perform DJ play.
- rekordbox dj  
The DJ performance functions of rekordbox are called rekordbox dj. Enter the license key on the rekordbox dj license key card included with this product to use rekordbox dj.

## Operating environment

Supported operating systems	CPU and required memory
Mac: macOS High Sierra 10.13/ Sierra 10.12 (latest update), OS X 10.11/10.10 (latest update)	Intel® processor Core™ i7, i5, i3 Intel® processor Core™ 2 Duo 2.0 GHz or better 4 GB or more of RAM
Windows: 32-bit version or 64-bit version of Windows 10, Windows 8.1, or Windows 7 (latest service pack)	Intel® processor Core™ i7, i5, i3 Intel® processor Core™ 2 Duo 2.0 GHz or better 4 GB or more of RAM
Others	
USB port	A USB 2.0 port is required to connect a computer to this unit.
Display resolution	1 280 x 768 or greater
Internet connection	An Internet connection is required for registering the rekordbox user account and downloading the software.

- For information on the latest system requirements, compatibility, and supported operating systems of rekordbox, see the site below.  
[rekordbox.com/system](http://rekordbox.com/system)
- Operation on all computers is not guaranteed, even if the computers meet the required operating environment.
- The CPU and hard disc may not provide sufficient processing capabilities depending on the power-saving setting, etc. on the computer. Confirm that the computer meets the conditions to provide constant high-performance (for example, connecting the computer to a power outlet to maintain a stable power supply) especially when using rekordbox on a laptop.
- A separate contract with an Internet service provider and payment of the utilization fee are required to access the Internet.
- Use the latest version/service pack of the operating system.

# Installing rekordbox

## Preparing rekordbox

Install the software by following the procedure below when you use rekordbox for the first time or if you are using rekordbox 4.x or an earlier version.

If you have already installed rekordbox Ver. 5.x, update it to the latest version from **rekordbox Update Manager**. In this case, the following installation procedure is not required. For details on the update procedure, access the site below and see "rekordbox Introduction".  
rekordbox.com/manual

- The user is responsible for preparing the computer, network devices, and other elements of the Internet usage environment required for a connection to the Internet.

## Installation procedure

The installation procedure differs depending on the operating system (OS) of your computer.

### ❖ Installation (Mac)

Do not connect this unit and the computer until the installation is completed.

- Close all the applications running on the computer before installing the software.

#### 1 Unzip the downloaded rekordbox software file.

#### 2 Double-click the rekordbox software to launch the installer.

#### 3 Read the license agreement, and select [Agree] if you agree to the terms.

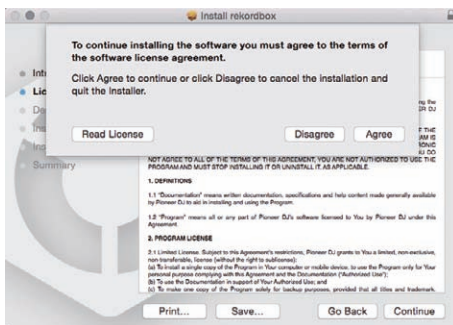

- If you do not agree to the contents of the license agreement, click [Disagree] to cancel the installation.

#### 4 If the installation completion screen appears, click [Close] to close the rekordbox installer.

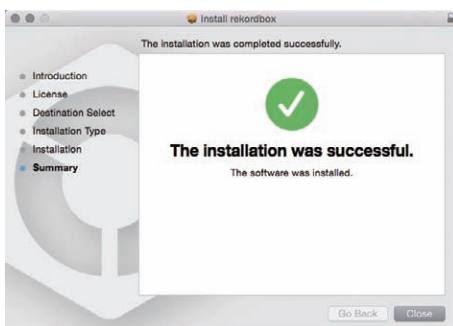

### ❖ Installation (for Windows)

Do not connect this unit and the computer until the installation is completed.

- Log in to the computer as the administrator before installation.
- Close all the applications running on the computer before installing the software.

#### 1 Unzip the downloaded rekordbox software file.

#### 2 Double-click the rekordbox software to launch the installer.

#### 3 Read the license agreement, select [Agree] if you agree to the terms, and click [Next].

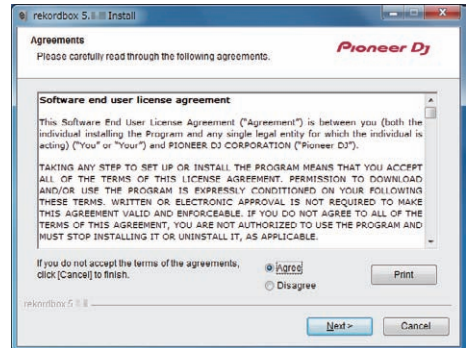

- If you do not agree to the license agreement, click [Cancel] to cancel the installation. After the installation destination is specified, the installation starts.

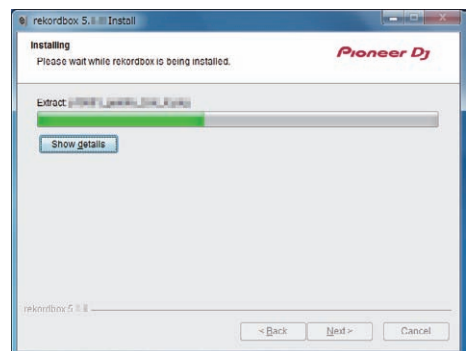

When the installation is completed, an installation successful message appears.

#### 4 Click [Finish] to close the rekordbox installer.

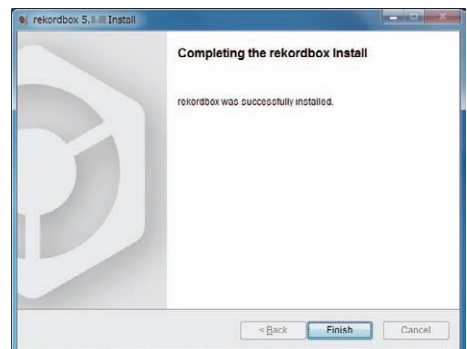

The installation is completed.

# Part names and functions

## Top panel of the unit

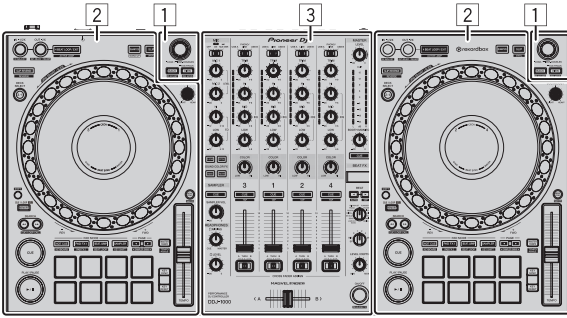

1 Browser section

2 Deck sections

3 Mixer section

## Browser section

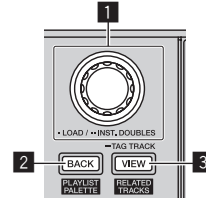

### 1 Rotary selector

Rotate:

Moves the selection cursor in rekordbox dj.

[SHIFT] + Rotate:

Enlarges or reduces the enlarged waveform display of rekordbox dj. Rotate to the right to enlarge the waveform display, and rotate to the left to reduce.

Press:

If this selector is pressed when the cursor is on a track, that track is loaded to the deck. If the rotary selector is pressed when the cursor is on a folder or playlist, the cursor moves from the tree view to the track list.

- If the playlist palette is displayed, the cursor can be moved among the tree view, the track list, and the playlist.
- The tree view, the track list, and the playlist palette are in the browser section of rekordbox dj. For details on the functions of each section, see the rekordbox Manual.

Press twice:

Loads the track loaded on the deck that is not being operated to the deck that is being operated. The track is loaded with the playback position unchanged.

### 2 BACK button

Press:

Moves the cursor between the tree view and track list each time the button is pressed.

- If the playlist palette is displayed, the cursor can be moved among the tree view, the track list, and the playlist.
- The tree view, the track list, and the playlist palette are in the browser section of rekordbox dj. For details on the functions of each section, see the rekordbox Manual.

[SHIFT] + Press:

Displays or hides the rekordbox dj playlist palette.

### 3 VIEW button

Press:

Reduces the size of the rekordbox dj deck display and expands the browser area display. Press again to undo the change.

[SHIFT] + Press:

Moves the cursor to [Related Tracks] in the tree view area.

Press + Hold:

Registers or deletes the selected track to [Tag List].

## Deck sections

The deck sections are used to control the four decks. The buttons and controls for operating decks 1 and 3 are located on the left side of the controller, and those for operating decks 2 and 4 are located on the right side of the controller.

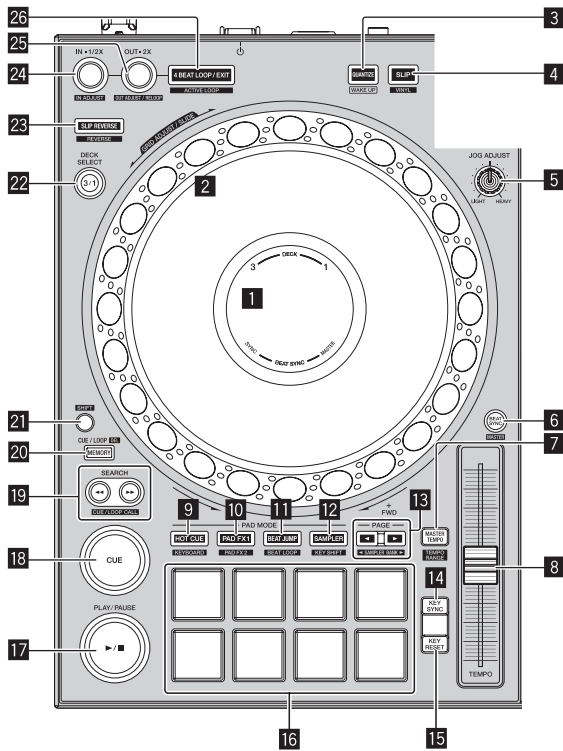

### 1 Jog dial display section

➔ *Jog dial display section* (p.8)

### 2 Jog dial

Rotate the top of the jog dial when VINYL mode is on:  
Performs scratching.

Rotate the outer section or rotate the top of the jog dial when VINYL mode is off:  
Performs pitch bending (adjustment of the playing speed).

[SHIFT] + Rotate top section:  
The beat grid interval for the loaded track can be adjusted.

[SHIFT] + Rotate the outer section:  
The entire beat grid of the loaded track can be slid to the left or right.

[SEARCH] + Rotate the top:  
The track is advanced at high speed in the direction in which the jog dial is turned.

### 3 QUANTIZE button

Press:  
Turns the quantize function on.  
If the quantize function is turned on when a hot cue is set, the point is automatically set to the nearest beat position.

- The resolution of the quantized beat can be selected in [Preferences] of rekordbox.

Press (in standby mode):  
Cancels standby mode.

- This function is only available for the button on the left side of the deck.

### 4 SLIP button

Press:  
Turns slip mode on and off.  
➔ *Using slip mode* (p.20)

[SHIFT] + Press:  
Turns VINYL mode on and off.

### 5 JOG FEELING ADJUST control

Adjusts the load applied when the jog dial is rotated.  
Rotate clockwise to increase the load, and rotate counterclockwise to decrease the load.

### 6 BEAT SYNC button

Press:  
Automatically synchronizes with the tempos (pitches) and beat grids of the deck set as the master for synchronization.

[SHIFT] + Press:  
Sets the deck whose button is pressed as the master deck for synchronization.

### 7 MASTER TEMPO button

Press:  
Turns the master tempo function on and off.  
When the master tempo function is on, the key does not change even if the playback speed is changed with the [TEMPO] slider.

[SHIFT] + Press:  
Changes the [TEMPO] slider's range of variation each time the button is pressed.

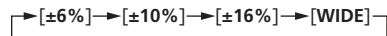

### 8 TEMPO slider

Adjusts the playing speed of tracks.

### 9 HOT CUE mode button

Press:  
Sets hot cue mode.  
➔ *Using hot cues* (p.17)

[SHIFT] + Press:  
Sets keyboard mode.  
➔ *Using the keyboard* (p.19)

### 10 PAD FX1 mode button

Press:  
Sets pad FX mode 1.  
➔ *Using the pad FX* (p.18)

[SHIFT] + Press:  
Sets pad FX mode 2.  
➔ *Using the pad FX* (p.18)

### 11 BEAT JUMP mode button

Press:  
Sets beat jump mode.  
➔ *Using beat jump* (p.18)

[SHIFT] + Press:  
Sets beat loop mode.  
➔ *Using beat loops* (p.19)

### 12 SAMPLER mode button

Press:  
Sets sampler mode.  
➔ *Using the sampler function* (p.19)

[SHIFT] + Press:  
Sets key shift mode.  
➔ *Using the key shift function* (p.19)

### 13 PAGE ◀, ▶ button

Press:  
Switches the page of the pad in each pad mode.  
➔ *Using the performance pads* (p.17)

**[SHIFT]** + Press:  
Switches the sampler bank.

#### 14 KEY SYNC button

Shifts the key of the track playing on the selected deck to the same key as the source track, to a dominant key (5 degrees higher), or to a subdominant key (4 degrees higher).

#### 15 KEY RESET button

Resets the key of the track playing on the selected deck to its original key.

#### 16 Performance pads

Achieves various performances.  
➔ *Using the performance pads* (p.17)

#### 17 PLAY/PAUSE ►/II button

Plays or pauses the track.

#### 18 CUE button

Sets, calls out, and plays cue points.

- Press the **[CUE]** button while paused to set a cue point.
- During playback, press the **[CUE]** button to return to the cue point and pause playback. (Back Cue)
- When the **[CUE]** button is pressed after playback returns to the cue point, playback continues while the button is kept pressed. (Cue Sampler)

#### 19 SEARCH ◀◀, ▶▶ buttons

Press:  
Searches for the beginning of a track.

Press + Hold:  
Fast-forwards or rewinds the track while the button is kept pressed.

**[SHIFT]** + Press:  
Calls out stored cue and loop points.

#### 20 MEMORY button

Press:  
Stores cue and loop points.

**[SHIFT]** + Press:  
Deletes stored cue and loop points.

#### 21 SHIFT button

Calls out another function if this button is pressed while a button is pressed.

#### 22 DECK selector button

Switches the deck to be operated.

#### 23 SLIP REVERSE button

Press:  
Plays a track in the reverse direction while this button is pressed, and resumes normal playback when the button is released.

- Normal playback continues in the background of the reverse playback. If the button is released, normal playback resumes from the current point playing in the background.
- Slip reverse play is automatically canceled after 8 beats and normal playback resumes even if the **[SLIP REVERSE]** button is kept pressed.

**[SHIFT]** + Press:  
Plays a track in the reverse direction. Reverse playback is canceled and normal playback resumes when the **[SHIFT]** and **[SLIP REVERSE]** buttons are pressed again.

#### 24 LOOP IN, LOOP 1/2X (IN•1/2X) button

Press:  
During normal playback, sets the loop-in point. During loop playback, shortens the length of loop playback to half.

**[SHIFT]** + Press:  
During loop playback, press this button while pressing the **[SHIFT]** button to fine-tune the loop-in point using the jog dial.

#### 25 LOOP OUT, LOOP 2X (OUT•2X) button

Press:  
During normal playback, sets the loop-out point and starts loop playback. During loop playback, doubles the length of loop playback.

**[SHIFT]** + Press:  
During loop playback, press this button while pressing the **[SHIFT]** button to fine-tune the loop-out point using the jog dial. Press this button while pressing the **[SHIFT]** button when loop playback is canceled to return to the loop-in point that was previously set and start loop playback.

#### 26 4 BEAT LOOP/EXIT button

Press:  
During normal playback, sets the auto beat loop for 4 beats and starts loop playback. During loop playback, cancels loop playback.

**[SHIFT]** + Press:  
Switches the status of the loop stored in the track between active and non-active. (Active Loop)

- If this button is pressed while the **[SHIFT]** button is pressed in playback mode, of the loops stored in that track, the loop closest to the playback position becomes active.
- When a loop that is stored in a track is called out, and this button is pressed while the **[SHIFT]** button is pressed, the loop that is called out becomes active or non-active.

## Jog dial display section

When a track from rekordbox is loaded, the following information is displayed on the jog dial display section.



### 1 Deck number display

The number of the deck currently being operated lights up.

### 2 Artwork display

Displays the artwork for the loaded track. You can change whether to display or hide the artwork in [Preferences] of rekordbox.

➔ *Changing the settings with rekordbox* (p.26)

### 3 Key display

Displays the current key.

### 4 Key variation display

Displays the variation between the track's original key and the current key.

### 5 Display CUE SCOPE

Displays with indicator marks the cue points, loop points, and hot cue points set in the interval from 4 bars before and 16 bars after the current playback position. Displays indicator marks in 4-bar intervals with the position of the set and called out cue or loop as a reference point. You can change whether to display or hide the CUE SCOPE in [Preferences] of rekordbox.

➔ *Changing the settings with rekordbox* (p.26)

### 6 Deck status display

The current status of the deck is indicated by the background color.

- White (bright): On-air with deck 1 or deck 2 selected
- White (dark): Off-air with deck 1 or deck 2 selected
- Blue (bright): On-air with deck 3 or deck 4 selected
- Blue (dark): Off-air with deck 3 or deck 4 selected
- Red (bright): Slip playback

- The display for slip playback has priority regardless of the deck's on-air status.

### 7 Cue point display

Displays the position of the set and called out cue point.

### 8 BPM display

The current BPM is displayed.

### 9 Playing speed display

The value changes according to the position of the [TEMPO] slider.

### 10 Playing speed adjustment range display

Displays the range that the playing speed can be adjusted.

### 11 Waveform display

Displays the waveform of the sound.

You can switch the color and format ([Full Waveform]/[Half Waveform]) of the waveform in association with the [Waveform]

setting in [Preferences] of rekordbox. For details on the procedure for changing the setting, see the rekordbox Manual.

### 12 Cue/loop/hot cue point memory display

Displays with indicator marks the cue points, loop points, and hot cue points set in the loaded track.

### 13 Playback position display

Displays the current playback position.

### 14 Time display (minutes, seconds)

Displays the remaining time or elapsed time.

You can change the displayed information in [Preferences] of rekordbox.

➔ *Changing the settings with rekordbox* (p.26)

- The loop beat is displayed in the time display during loop playback.

### 15 MASTER display

Lights up when the deck being operated is set as the master.

### 16 Operation display

Displays the current playback position.

Rotates during playback, and stops when paused.

### 17 SYNC display

Lights up when [BEAT SYNC] is turned on.

## Mixer section

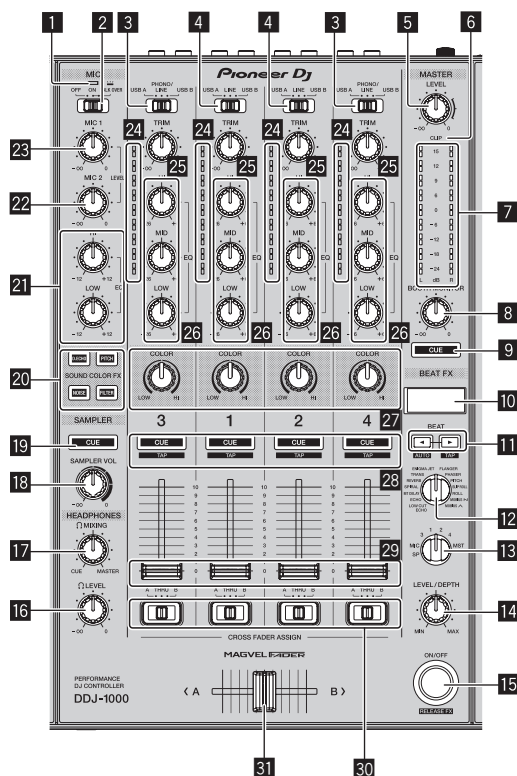

### 1 Microphone indicator

➔ *Using a microphone* (p.24)

### 2 OFF, ON, TALK OVER selector switch

Turns the microphone on and off.

➔ *Using a microphone* (p.24)

### 3 USB A, PHONO/LINE, USB B selector switch

Selects the input source for each channel from the components connected to this unit.

- [USB A]: Uses the track loaded in the rekordbox dj deck.



- **[PHONO/LINE]**: Uses a phono level (for MM cartridges) output device (analog player, etc.) connected to the **[LINE/PHONO]** input terminals.
  - ➔ *Using external inputs* (p.25)
  - **[USB B]**: Uses the track loaded in the rekordbox dj deck.
- 4 USB A, LINE, USB B selector switch**  
Selects the input source for each channel from the components connected to this unit.
- **[USB A]**: Uses the track loaded in the rekordbox dj deck.
  - **[LINE]**: Uses a line level output device (DJ player, etc.) connected to the **[LINE]** input terminals.
- ➔ *Using external inputs* (p.25)
- **[USB B]**: Uses the track loaded in the rekordbox dj deck.
- 5 MASTER LEVEL control**  
Adjusts the level of sound output to the master channel.
- 6 CLIP indicator**  
**[CLIP]** blinks when the output level is too high.
- Blinking slowly: indicates that the sound is about to be distorted.
  - Blinking quickly: Indicates that the sound is distorted.
- 7 Master level indicator**  
Displays the level of sound output to the master channel.
- 8 BOOTH MONITOR LEVEL control**  
Adjusts the level of sound output to the booth channel.
- 9 MASTER CUE button**  
Outputs the sound of the master channel to the headphones.
- 10 Effect section display**  
Displays the effect name, BPM, effect parameter, etc.
- 11 BEAT ◀, ▶ buttons**  
Press:  
Set the beat fraction to synchronize the effect sound with.
- Press **[SHIFT]** + **[BEAT ◀]**:  
Sets the mode for automatically measuring the BPM from the input audio signal.
- Press **[SHIFT]** + **[BEAT ▶]**:  
Sets the mode for inputting the BPM manually.
- 12 BEAT FX SELECT control**  
Sets the BEAT FX type.
- 13 BEAT FX CH SELECT control**  
Switches the channel to which the BEAT FX is to be applied.
- 14 BEAT FX LEVEL/DEPTH control**  
Adjusts the BEAT FX quantitative parameter.
- 15 BEAT FX ON/OFF button**  
Press:  
Turns BEAT FX on and off.
- [SHIFT]** + Press:  
Turns release FX on for rekordbox.
- ➔ *Using the BEAT FX function* (p.21)
- 16 HEADPHONES LEVEL control**  
Adjusts the level of sound output to the headphones.
- 17 HEADPHONES MIXING control**  
Adjusts the balance of the monitor volume between the sound of the channels for which the headphones **[CUE]** button is pressed and the sound of the master channel.
- 18 SAMPLER VOL control**  
Adjusts the sound level of the sampler.
- 19 SAMPLER CUE button**  
Outputs the sound of the sampler to the headphones.
- 20 SOUND COLOR FX SELECT buttons**  
Turns on and off SOUND COLOR FX.  
➔ *Using the SOUND COLOR FX function* (p.24)
- 21 MIC EQ (HI, LOW) controls**  
Adjusts the tone quality of the **[MIC1]** and **[MIC2]** channels.
- 22 MIC2 LEVEL control**  
Adjusts the level of sound output from the **[MIC2]** channel.
- 23 MIC1 LEVEL control**  
Adjusts the level of sound output from the **[MIC1]** channel.
- 24 Channel level indicator**  
Displays the sound level of each channel before it passes through the channel faders.
- 25 TRIM control**  
Adjusts the level of sound output from each channel.
- 26 EQ (HI, MID, LOW) control**  
Boosts or cuts frequencies for the different channels.
- 27 COLOR control**  
Changes the parameters of the SOUND COLOR FX of the different channels.
- 28 Headphones CUE button**  
Press:  
Outputs the sound of the channel for which this button is pressed to the headphones.
- [SHIFT]** + Press:  
The tempo for each deck can be set by tapping this button. (Tap function)
- 29 Channel fader**  
Adjusts the level of sound output from each channel.
- 30 Crossfader assign selector switch**  
Assigns the channel output to the crossfader.  
**[A]**: Outputs to **[A]** (left) of the crossfader.  
**[B]**: Outputs to **[B]** (right) of the crossfader.  
**[THRU]**: Select when not using the crossfader. The signals do not pass through the crossfader.
- 31 Crossfader**  
Outputs the sound assigned by the crossfader assign switch.

Do not pull the channel fader and crossfader knobs with excessive force. The knobs are not detachable. Pulling the knobs with excessive force may break the unit.

## Rear panel

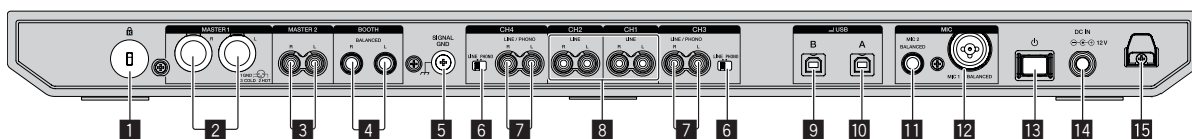

### 1 Kensington security slot

### 2 MASTER 1 output terminal

Connect a powered speaker, a power amp, etc.

- Compatible with XLR connector type balanced outputs. Be sure to use these as balanced outputs.
- **Be careful not to accidentally insert the power cord of another unit.**
- **Do not connect a terminal that can supply phantom power.**

### 3 MASTER 2 output terminal

Connect a powered speaker, a power amp, etc.

- Compatible with RCA pin-jack type unbalanced outputs.

### 4 BOOTH output terminal

Output terminals for a booth monitor.

- Compatible with TRS connector type balanced outputs. Be sure to use these as balanced outputs.
- The master channel sound can be output from the [BOOTH] output terminals regardless of the audio level set for the master channel. The sound level can be adjusted using the [BOOTH MONITOR LEVEL] control.

### 5 SIGNAL GND terminal

Connect a ground wire of an analog player to reduce noise that occurs when an analog player is connected.

### 6 LINE/PHONO switch

Selects the input source for each channel from the components connected to this unit.

- [LINE]: Uses a line level output device (DJ player, etc.) connected to the [LINE/PHONO] input terminals.
- [PHONO]: Uses a phono level (for MM cartridges) output device (analog player, etc.) connected to the [LINE/PHONO] input terminals.

### 7 LINE/PHONO input terminals

Connect a phono level (for MM cartridges) output device (analog player, etc.) or a line level output device (DJ player, etc.). Switch the input source according to the connected device using the [LINE/PHONO] switch on the rear panel of this unit.

- Set the [USB A, PHONO/LINE, USB B] selector switch on top of the unit to [PHONO/LINE] beforehand.

### 8 LINE input terminals

Connect to a DJ player or other line level device.

- Set the [USB A, LINE, USB B] selector switch on top of the unit to [LINE] beforehand.

### 9 USB terminals (USB B)

Connect to a computer.

- Connect this unit to your computer directly via the USB cable included with this product or one that conforms to USB 2.0.
- Do not use a USB hub.

### 10 USB terminals (USB A)

Connect to a computer.

- Connect this unit to your computer directly via the USB cable included with this product or one that conforms to USB 2.0.
- Do not use a USB hub.

### 11 MIC2 input terminals

Connect a microphone.

- Only phone plugs (Ø 6.3 mm) can be used.

### 12 MIC1 input terminals

Connect a microphone.

- Either an XLR connector or a phones plug (Ø 6.3 mm) can be used.

### 13 ⏻ switch

Turns this unit on or puts this unit into standby mode.

### 14 DC IN terminal

Connect to a power outlet using the included AC adapter (with the included power cord connected).

- Connect the AC adapter after all the connections between devices are completed.
- Use the included AC adapter.

### 15 DC cord hook

Hook for the AC adapter power cord.

- If the AC adapter is disconnected during playback, the sound will be interrupted.

## Front panel

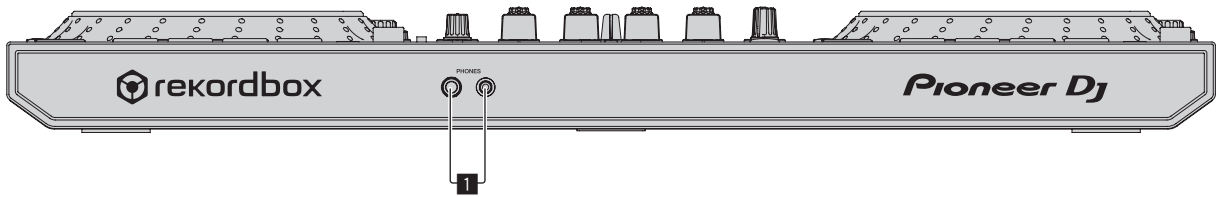

### **1** PHONES output terminals

Connect headphones.

Stereo phone plugs (ø 6.3 mm) and stereo mini phone plugs (ø 3.5 mm) can be used.

# Basic operation

- Connect the power cord to a power outlet after all the connections are completed.  
Turn off this unit and disconnect the power cord from the power outlet before connecting components or changing the connections.  
Refer to the operating instructions for the components to be connected.
- Be sure to use the included power cord and AC adapter.
- Be sure to use the USB cable included with this product or one that conforms to USB 2.0.
- A USB hub cannot be used.

## Example of connections

### Connecting input terminals

#### Rear panel

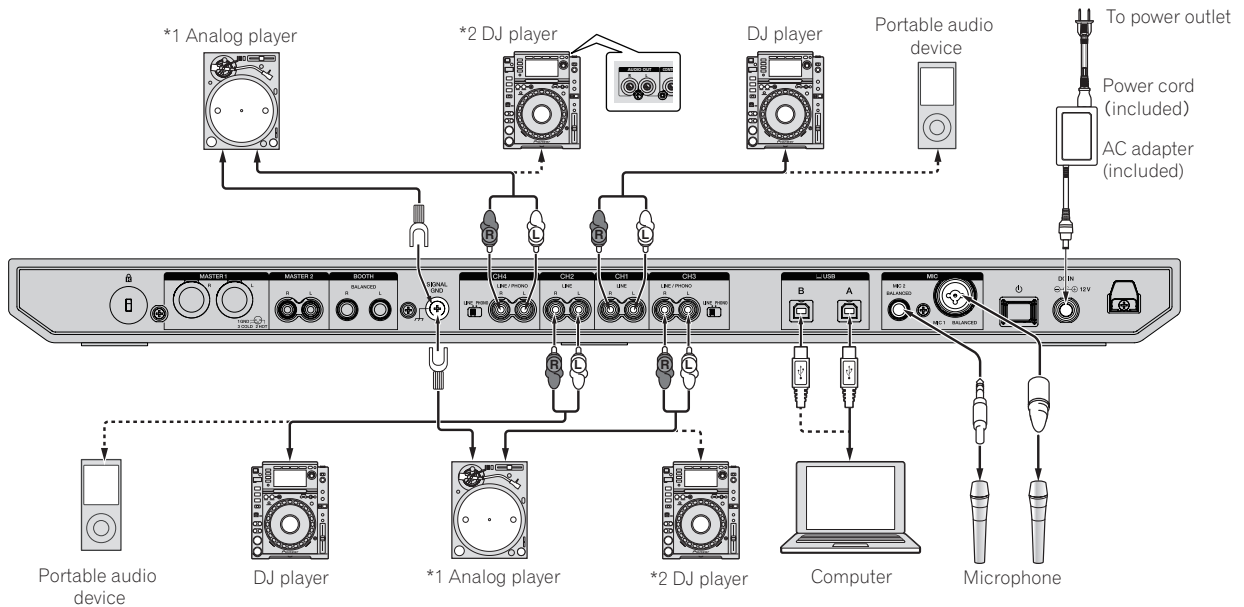

\*1 When connecting an analog player, switch the [LINE/PHONO] switch beside the terminals to [PHONO].

\*2 When connecting a DJ player, switch the [LINE/PHONO] switch beside the terminals to [LINE].

### Cord hook

#### ● Hooking the AC adapter power cord onto the cord hook

Fasten the AC adapter power cord into place by hooking it onto the cord hook. This prevents the power cord from being accidentally pulled and causing the plug to get disconnected from the terminal.

- Do not fasten with the base of the AC adapter power cord bent. If used continuously under these conditions, the power cord may be damaged, resulting in faulty contact.
- If the AC adapter is disconnected during playback, the sound will be interrupted.

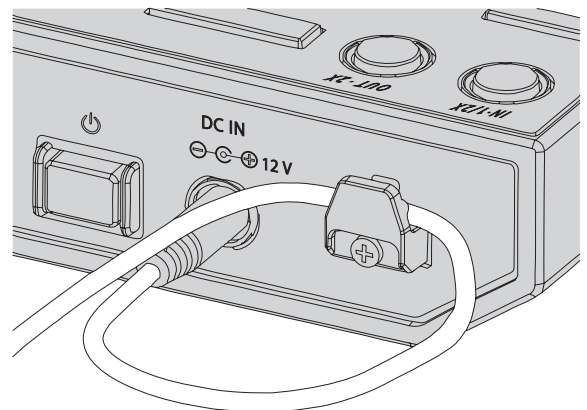

## Connecting output terminals

### Rear panel

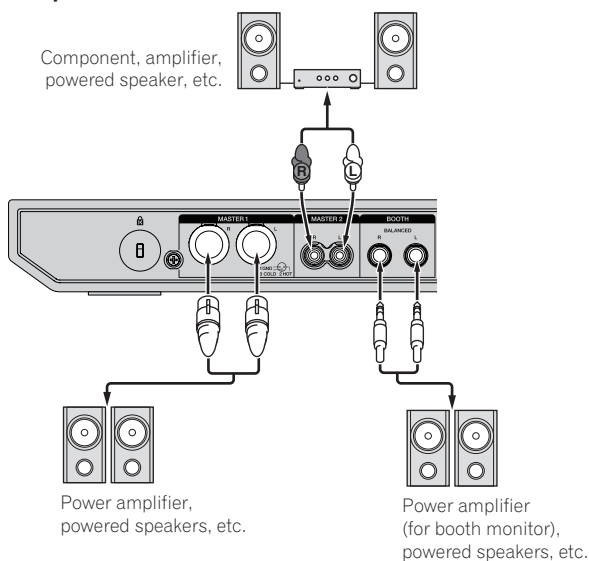

### Front panel

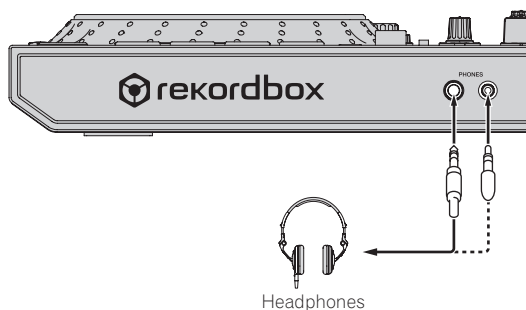

- 1 Be sure to use the **[MASTER 1]** output terminals for a balanced output. If they are connected to an unbalanced input (such as RCA) using an XLR to RCA converter cable (or converter adapter), etc., the sound quality may be lowered or noise may occur. For connection with an unbalanced input (such as RCA), use the **[MASTER 2]** output terminals.
- 2 **Be careful not to accidentally insert the power cord plug of another unit into a [MASTER 1] output terminals. Do not connect terminals capable of supplying phantom power to the [MASTER 1] output terminals.**
- 3 Be sure to use the **[BOOTH]** output terminals for a balanced output. If they are connected to an unbalanced input (such as an RCA or TS terminal) with an TRS to RCA converter cable (or converter adapter), TS cable, etc., the sound quality may be lowered or noise may occur.

## Connections

1 Connect headphones to the [PHONES] output terminals.

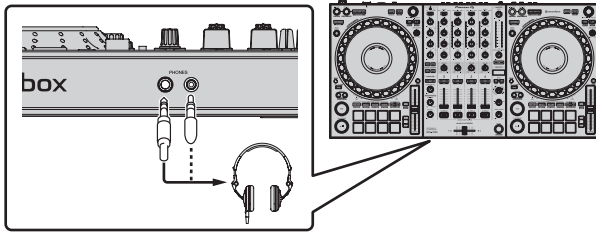

2 Connect devices such as powered speakers, a power amplifier, and components to the [MASTER 1] or [MASTER 2] output terminals.

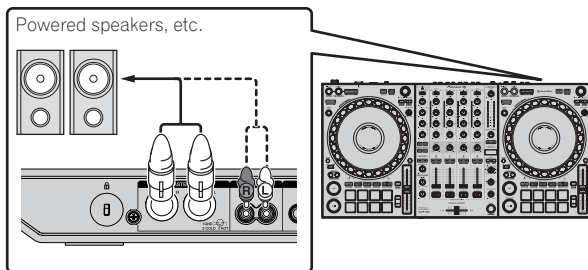

- To output the sound from the [BOOTH] output terminals, connect devices such as speakers to the [BOOTH] output terminals.

3 Connect this unit to your computer using a USB cable.

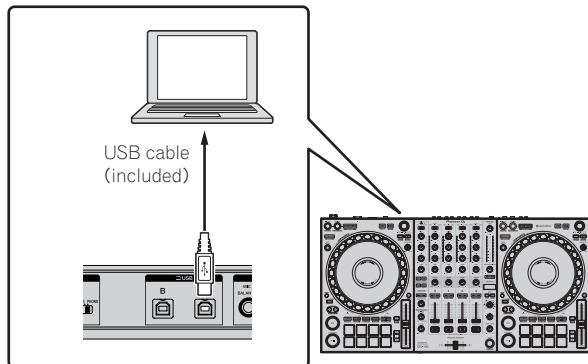

4 Turn the computer on.

5 Connect the AC adapter.

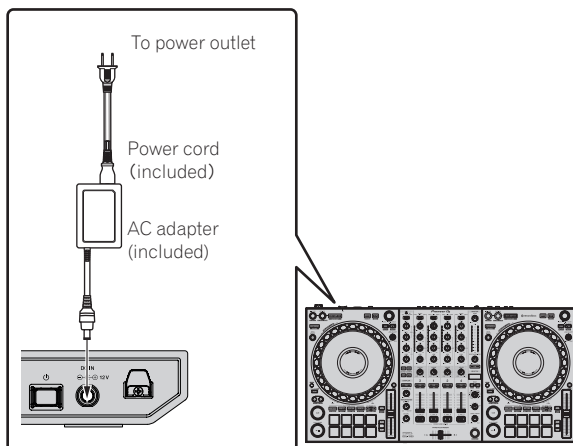

6 Press the [⏻] switch on the rear panel of this unit to turn this unit on.

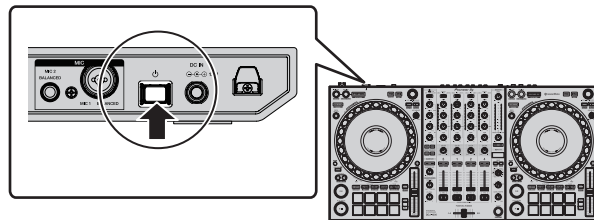

This unit turns on.

- For Windows  
[Installing device driver software] may appear when this unit is connected to the computer for the first time or connected to a different USB port on the computer. Wait for a while until [Your devices are ready for use] appears.

7 Turn on the devices connected to the output terminals (powered speakers, power amplifier, components, etc.).

- If a microphone, DJ player or other external device is connected to the input terminals, turn on the connected device.

---

---

## Starting the system

---

### Launching rekordbox

Account registration and activation work for rekordbox dj are required at first startup. For details on each work procedure, access the site below and see "rekordbox Introduction".  
rekordbox.com/manual

#### For Mac

Open the [Applications] folder in Finder, and double-click the [rekordbox] icon.

#### For Windows 10

From the [Start] menu, click [Pioneer] > [rekordbox] icon.

#### For Windows 8.1

Click the [rekordbox] icon in [Apps view].

#### For Windows 7

Click the [Start] menu > [All Programs] > [Pioneer] > [rekordbox X.X.X X.X.X] > the [rekordbox X.X.X] icon in order.

---

## Checking audio settings

Check that the [Audio] settings in [Preferences] of rekordbox are set as follows.

#### For Mac

[Audio]: [DDJ-1000]

[Output channels]:

[Master Output]: [DDJ-1000: MASTER]

[Headphones Output]: [DDJ-1000: HEADPHONES]

#### For Windows

[Audio]: [DDJ-1000 ASIO]

[Output channels]:

[Master Output]: [DDJ-1000 ASIO: MASTER]

[Headphones Output]: [DDJ-1000 ASIO: HEADPHONES]

If PC MASTER OUT is enabled, the "+ Name of audio device in computer" information will also be displayed after [MASTER] of the [Master Output] item in the [Audio] settings.

---

## Adding music files to [Collection]

A list of track files managed by rekordbox is displayed on the [Collection] screen.

Register the track files on the computer as the collection of music for rekordbox and analyze them to enable those tracks to be used with rekordbox.

### 1 Click [Collection] in the tree view.

A list of the tracks registered in [Collection] is displayed.

### 2 Open Finder or Windows Explorer, and drag and drop track files or folders containing track files to the track list.

The track files are added to [Collection], and the waveform analysis of the track files starts. Wait until the analysis of all the track files is finished.

---

---

## Loading tracks into a deck

The following describes the procedure for loading tracks into deck 1 (left side) as an example.

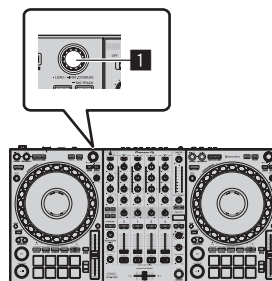

### 1 Rotary selector

- Turn the rotary selector of deck 1 (left side) to select a track in [Collection] and then press the rotary selector.

The track is loaded into deck 1.

## Playing a music file

The following describes the procedure for outputting the sound of deck 1 (left side) as an example.

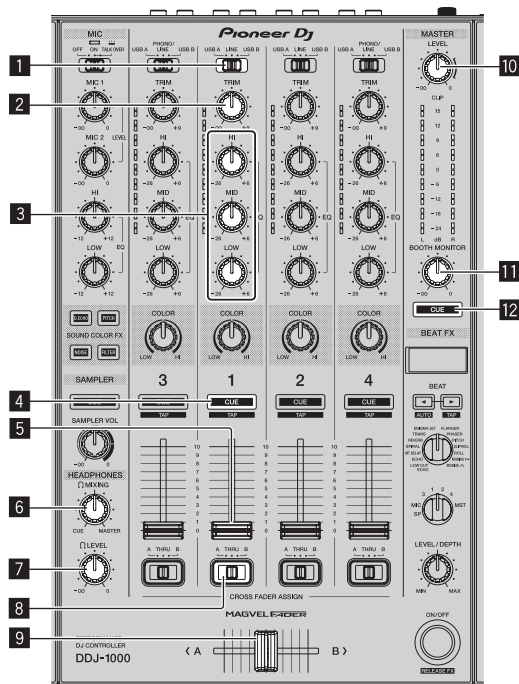

- 1 USB A, LINE, USB B selector switch
- 2 TRIM control
- 3 EQ (HI, MID, LOW) control
- 4 Headphones CUE button
- 5 Channel fader
- 6 HEADPHONES MIXING control
- 7 HEADPHONES LEVEL control
- 8 Crossfader assign selector switch
- 9 Crossfader
- 10 MASTER LEVEL control
- 11 BOOTH MONITOR LEVEL control
- 12 MASTER CUE button

1 Set the following as specified.

Part	Operation
USB A, LINE, USB B selector switch	USB A
TRIM control	Rotate it clockwise until it stops.
EQ (HI, MID, LOW) control	Center position
COLOR control	Center position
Channel fader	Move it forward.
MASTER LEVEL control	Rotate it clockwise until it stops.
Crossfader	Center position
Crossfader assign selector switch	[THRU] position

2 Press the [PLAY/PAUSE ►/II] button to play the track.

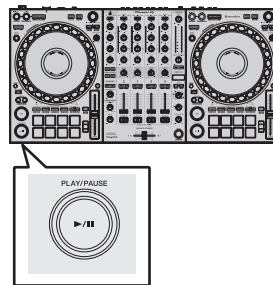

3 Rotate the [TRIM] control.

Adjust the [TRIM] control to confirm that the channel level indicator lights up in orange at the highest volume.

4 Move the channel fader forward.

5 Rotate the [MASTER LEVEL] control to adjust the sound level of the speakers.

Adjust the level of the sound output from the [MASTER 1] and [MASTER 2] output terminals to an appropriate level.

- To output sound from the computer's speaker, adjust the volume of the computer's speaker instead of the [MASTER LEVEL] control.

## Monitoring sound with headphones

Set the following as specified.

Part	Operation
HEADPHONES MIXING control	Center position
HEADPHONES LEVEL control	Rotate it clockwise until it stops.

1 Press the headphones [CUE] button for channel 1.

2 Rotate the [HEADPHONES LEVEL] control.

Adjust the level of sound output from the headphones to an appropriate level.



### Note

This unit and rekordbox dj include many functions to allow for more individualistic DJ performances. For details on each function, access the site below and see the "rekordbox Manual".  
[rekordbox.com/manual](http://rekordbox.com/manual)

## Turning off the system

1 Close rekordbox.

2 Press the [⏻] switch on the rear panel of this unit to set the unit to standby.

3 Disconnect the USB cable from the computer.



# Advanced operation

## Using 4 beat loops

- During loop playback, press the [4 BEAT LOOP/EXIT] button.

A 4 beat loop automatically starts from the point where the button is pressed, and loop playback starts.

- When the quantize function is on, there may be a slight delay in operation of this function to synchronize the beat.

## Canceling loop playback

- Press the [4 BEAT LOOP/EXIT] button again.

Playback continues beyond the loop-out point without returning to the loop-in point.

## Using manual loops

Use this function to play specific sections repeatedly.

- When the quantize function is on, there may be a slight delay in operation of this function to synchronize the beat.

- 1 During playback, press the [IN•1/2X] button at the point where you want to start loop playback (the loop-in point).

The loop-out point is set.

- 2 Press the [OUT•2X] button at the point where you want to end loop playback (the loop out point).

## Cutting loops

- During loop playback, press the [IN•1/2X] button.

Each time the button is pressed, the length of the loop playback is cut in half.

- The length of the loop can be cut in half even during 4 beat loop playback.

## Extending loops

- During loop playback, press the [OUT•2X] button.

Each time the button is pressed, the length of the loop playback is doubled.

- The length of the loop can be doubled even during 4 beat loop playback.

## Canceling loop playback

- Press the [4 BEAT LOOP/EXIT] button.

Playback continues beyond the loop-out point without returning to the loop-in point.

## Changing the point where loop playback starts

- Press the [IN•1/2X] button while pressing the [SHIFT] button, and rotate the jog dial.

Moves the position of the loop-in point.

## Changing the point where loop playback ends

- Press the [OUT•2X] button while pressing the [SHIFT] button, and rotate the jog dial.

Moves the position of the loop-out point.

## Using the performance pads

### Using hot cues

You can start playback from the position where a hot cue is set. In addition to hot cues, loops can be set to call out a playback point.

- Up to 16 hot cue points can be set and stored in one track.

#### ❖ Setting and calling out a hot cue

- 1 Press the [HOT CUE] mode button.

This unit enters hot cue mode.

- For the registered 16 hot cues, you can switch to hot cues A to H by pressing the [PAGE ◀] button, and hot cues I to P by pressing the [PAGE ▶] button. The content of the hot cue display area within the rekordbox dj deck screen can also be switched by performing the same operation.

- 2 During playback or in pause mode, press a performance pad to set a hot cue point.

The hot cue points are assigned to the respective performance pads as shown below.

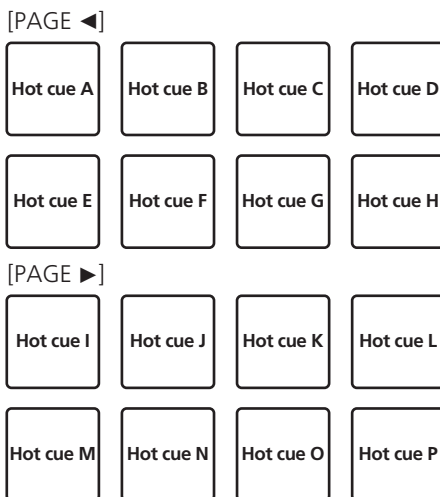

- 3 Press the performance pad to which the hot cue point is set.

Playback starts from the hot cue point.

- Press a performance pad while pressing the [SHIFT] button to clear the hot cue point.

#### ❖ Setting and calling out a 4 beat loop

- 1 Press the [HOT CUE] mode button.

This unit enters hot cue mode.

## 2 During loop playback, press the [4 BEAT LOOP/EXIT] button.

Sets a 4 beat loop at the point where the button is pressed, and loop playback starts.

## 3 During loop playback, press a performance pad to set a loop during loop playback.

## 4 Press the performance pad to which the loop is set.

Loop playback starts from the point where the loop is set.

- Press a performance pad while pressing the [SHIFT] button to clear the loop.

### ❖ Setting and calling out a manual loop

## 1 Press the [HOT CUE] mode button.

This unit enters hot cue mode.

## 2 During playback, press the [IN•1/2X] button, and press the [OUT•2X] button.

Loop playback starts.

## 3 During loop playback, press a performance pad to set a loop during loop playback.

## 4 Press the performance pad to which the loop is set.

Loop playback starts from the point where the loop is set.

- Press a performance pad while pressing the [SHIFT] button to clear the loop.

---

## Using the pad FX

Various performances are possible with the simple operation of pressing and releasing performance pads.

## 1 Press the [PAD FX1] mode button.

This unit enters pad FX mode 1.

Effects are assigned to the performance pads as shown below.

For the effects assigned to the pads, you can switch to effects A to H by pressing the [PAGE ◀] button, and effects I to P by pressing the [PAGE ▶] button. The content of the pad FX display area within the rekordbox dj deck screen can also be switched by performing the same operation.

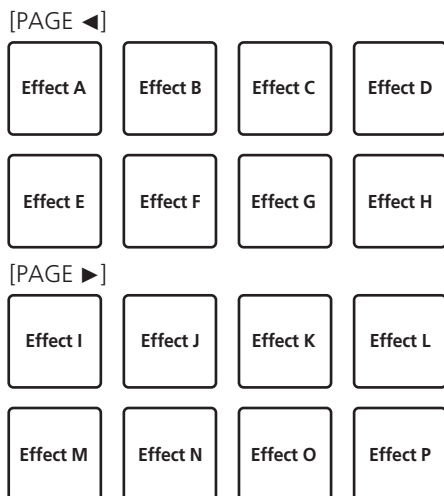

- Press the [PAD FX1] mode button while pressing the [SHIFT] button to switch to pad FX mode 2. Effects are assigned to the performance pads as shown below.

For the effects assigned to the pads, you can switch to effects Q to X by pressing the [PAGE ◀] button, and effects Y to AF by pressing the [PAGE ▶] button. The content of the pad FX display area within

the rekordbox dj deck screen can also be switched by performing the same operation.

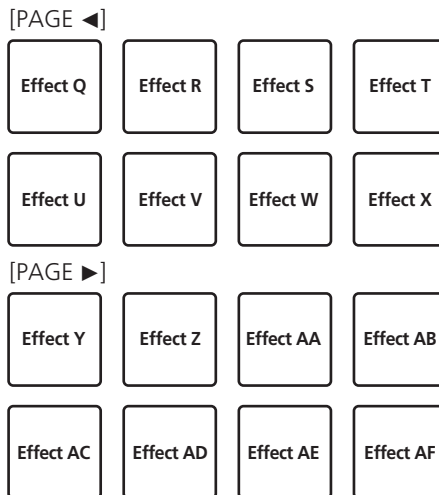

## 2 Press and hold a performance pad.

The effect turns on according to the effect and number of beats assigned to the pad.

## 3 Release the performance pad.

The effect turns off.

### ❖ Using the release FX of the pad FX

Release FX must be assigned to a performance pad beforehand.

## 1 Press and hold a performance pad to which an effect other than release FX is assigned.

The effect turns on according to the effect and number of beats assigned to the pad.

## 2 Press the performance pad to which release FX is assigned.

The effect that was on turns off, and the release FX effect is added.

---

## Using beat jump

You can move the playback position instantly without breaking the rhythm of the track currently playing.

## 1 Press the [BEAT JUMP] mode button.

This unit enters beat jump mode.

The number of beats or number of bars skipped is assigned to the respective performance pads as shown below. (Default value)

- Press the [PAGE ◀] button or the [PAGE ▶] button to switch the number of beats or number of bars assigned to the performance pad.



## 2 Press pad 1, pad 3, pad 5, or pad 7.

The playback position moves to the left by the number of beats or number of bars assigned to the pressed pad.

## 3 Press pad 2, pad 4, pad 6, or pad 8.

The playback position moves to the right by the number of beats or number of bars assigned to the pressed pad.

## Using the sampler function

You can play the tracks loaded in the sampler slots of the sampler using the performance buttons.

### ❖ Preparing to use the sampler

#### Select the [SAMPLER] check box at the upper part of the rekordbox dj screen.

The sampler panel appears on the rekordbox dj screen.

### ❖ Loading a track into a sampler slot

#### 1 Press the [SAMPLER] mode button.

This unit enters sampler mode.

#### 2 Press the [PAGE ◀] button or the [PAGE ▶] button while pressing the [SHIFT] button.

The sampler bank is switched. The sampler has four banks and each bank has sixteen slots.

#### 3 Press the rotary selector to move the cursor to the track list.

#### 4 Rotate the rotary selector.

Select the track to be loaded in a sampler slot.

#### 5 Press the performance pad while pressing the [SHIFT] button.

The selected track is loaded into the sampler slot.

- Loading by overwriting an already loaded sampler slot may not be possible depending on the [Preferences] setting of rekordbox.

### ❖ Using the performance pads to play the sampler

#### 1 Press the [SAMPLER] mode button.

This unit enters sampler mode.

#### 2 Press the [PAGE ◀] button or the [PAGE ▶] button while pressing the [SHIFT] button.

Switches the sampler bank.

#### 3 Adjusting the sampler gain on the rekordbox dj screen

#### 4 Press a performance pad.

The sound for the slot assigned to the pad is played.

- Sampler slots are assigned to the respective performance pads as shown below.

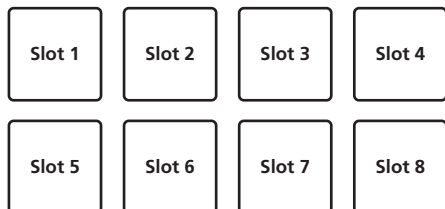

#### 5 During sampler playback, press a performance pad.

Playback continues by returning to the beginning.

#### 6 During sampler playback, press the performance pad while pressing the [SHIFT] button.

The sound of the slot that is currently playing stops.

## Using the keyboard

You can use the performance pads as a keyboard, assigning a musical scale to the hot cues.

#### 1 Press the [HOT CUE] mode button while pressing the [SHIFT] button.

This unit enters keyboard mode.

- Press the [PAGE ◀] button or the [PAGE ▶] button to switch the pitch of the sound assigned to the performance pad.

#### 2 Press a performance pad.

Select the hot cue to use in keyboard mode.

- If there are no hot cues set, the currently playback position is set as a hot cue and is used in keyboard mode.
- If you want to reselect the hot cue to use in keyboard mode, press the [HOT CUE] mode button while pressing the [SHIFT] button.

#### 3 Press a performance pad.

The hot cue is played in the pitch assigned to the pressed pad.

## Using beat loops

When a performance pad is pressed, a loop with the number of beats or number of bars assigned to that pad is set, and loop playback continues even if the pad is released.

#### 1 Press the [BEAT JUMP] mode button while pressing the [SHIFT] button.

This unit enters beat loop mode.

The number of beats or number of bars for beat loop mode is assigned to the respective performance pads as shown below.

- Press the [PAGE ◀] button or the [PAGE ▶] button to switch the number of beats or number of bars assigned to the performance pad.

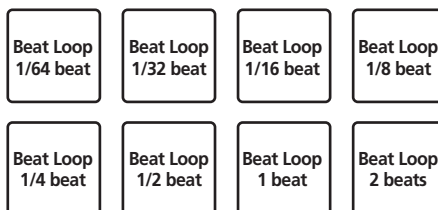

#### 2 Press a performance pad.

Loop playback is performed for a loop with the number of beats or number of bars assigned to the pressed pad.

#### 3 Press the same performance pad again.

Loop playback is canceled.

## Using the key shift function

When a performance pad is pressed, the key of the track being played changes to the pitch assigned to that pad.

#### 1 Press the [SAMPLER] mode button while pressing the [SHIFT] button.

This unit enters key shift mode.

- Press the [PAGE ◀] button or the [PAGE ▶] button to switch the pitch of the sound assigned to the performance pad.

#### 2 Press a performance pad.

The key of the track being played changes to the pitch assigned to the pad that is pressed.

#### 3 Press the [KEY RESET] button.

The key of the track being played changes to the pitch assigned to the pad that is pressed.

## Setting cue points

Cue points or loop points can be set in the loaded track.

#### 1 Move the playback position to the point where you want to set a cue point.

2 Press the [CUE] button in the pause mode.

3 Press [MEMORY].

The cue point set in step 2 is stored.

Press the [MEMORY] button while looping to store the loop point.

---

## Calling out cue points

Set cue points or loop points can be called out.

● While pressing the [SHIFT] button, press the [SEARCH ◀◀] button or the [SEARCH ▶▶] button.

Calls out the set cue points or loop points.

---

## Deleting cue points

Set cue points or loop points can be deleted.

1 While pressing the [SHIFT] button, press the [SEARCH ◀◀] button or the [SEARCH ▶▶] button.

Call out the cue point that you want to delete.

2 Press the [MEMORY] button while pressing the [SHIFT] button.

The cue point called out is deleted.

---

---

## Using slip mode

When slip mode is turned on, normal playback with the original rhythm continues in the background during scratching, looping and hot cue playback. When scratching, looping or hot cue playback is canceled, normal playback resumes from the position where the operation was canceled.

Various performances can be achieved without breaking the rhythm.

- The [SLIP] button lights up when slip mode is set and flashes while playing the sound in the background.

---

## Slip scratching

1 Turn VINYL mode on.

Press the [SHIFT] button to check if the [SLIP] button lights up.

2 Press the [SLIP] button.

This unit enters slip mode.

3 During playback, perform scratching using the top of the jog dial.

Normal playback continues in the background while scratching is performed.

4 Release the top of the jog dial.

Playback starts from the current position playing in the background playback.

- Press the [SLIP] button again to cancel slip mode.

---

## How to check VINYL mode on/off

VINYL mode is turned on by default, and scratching is available. You can check the current status based on the light status of the [SLIP] button while the [SHIFT] button is pressed.

- When VINYL mode is on, the [SLIP] button lights up while the [SHIFT] button is pressed.
- When VINYL mode is off, the [SLIP] button does not light up while the [SHIFT] button is pressed.

Press the [SLIP] button while pressing the [SHIFT] button to switch VINYL mode on and off.

---

## Slip hot cue

1 Press the [HOT CUE] mode button.

This unit enters hot cue mode.

2 Set the hot cue.

Press a performance pad to set a hot cue.

3 Press the [SLIP] button.

This unit enters slip mode.

4 During playback, press and hold a performance pad.

Playback starts from the position where the hot cue is set. Playback continues while the performance pad is pressed.

Normal playback continues in the background while playing the hot cue.

5 Release the performance pad.

Playback starts from the current position playing in the background playback.

- Press the [SLIP] button again to cancel slip mode.

---

## Slip braking

1 Adjust the setting for [Vinyl Speed Adjust] - [Touch/Brake] in the [Deck] tab of [Preferences] > [Controller] menu for rekordbox.

Adjusts the speed, etc., at which track playback stops with

[Vinyl Speed Adjust].

When using slip braking, adjust the [Touch/Brake] control of [Vinyl Speed Adjust] on the computer screen and set to stop the sound slowly.

2 Press the [SLIP] button.

This unit enters slip mode.

3 During playback, press the [PLAY/PAUSE ▶/II] button.

Playback slowly stops while normal playback continues in the background.

4 Press the [PLAY/PAUSE ▶/II] button again.

Playback starts from the current position playing in the background playback.

- Press the [SLIP] button again to cancel slip mode.

---

## Slip auto beat loop

1 Press the [SLIP] button.

This unit enters slip mode.

2 Press the [4 BEAT LOOP/EXIT] button.

A loop with the specified number of beats is set and loop playback starts. Normal playback continues in the background even during loop playback.

3 Press the [4 BEAT LOOP/EXIT] button again.

Loop playback is canceled and playback starts from the current position playing in the background playback.

- Press the [SLIP] button again to cancel slip mode.

---

## Manual slip looping

1 Press the [SLIP] button.

This unit enters slip mode.

2 Press the [IN•1/2X] button, and press the [OUT•2X] button.

Loop playback starts.

Normal playback continues in the background even during loop playback.

### 3 Press the [4 BEAT LOOP/EXIT] button.

Loop playback is canceled and playback starts from the current position playing in the background playback.

- Press the [SLIP] button again to cancel slip mode.

## Using the fader start function

### Using the channel fader start function

#### 1 Set a cue point.

Pause playback at the position where you want to set a cue point (playback start point), and press the [CUE] button for the corresponding deck.

- Cue points can also be set by moving the channel fader from the back to the position nearest you while pressing the [SHIFT] button in the pause mode.

#### 2 Move the channel fader from the position nearest you towards the back while pressing the [SHIFT] button.

Playback of the track starts from the set cue point.

- When the channel fader is moved back to the position nearest you while pressing the [SHIFT] button during playback, the track moves back to the set cue point and playback is paused (back cue).

If a cue point is not set, playback starts from the beginning of the track.

When the channel fader is moved from the back to the position nearest you while pressing the [SHIFT] button when a cue is in standby, playback starts from the set cue point.

### Using the crossfader start function

To use the crossfader start function, set the crossfader assign selector switch of the channel to [A] or [B].

#### 1 Set a cue point.

Pause playback at the position where you want to set a cue point (playback start point), and press the [CUE] button for the corresponding deck.

- Cue points can also be set by moving the crossfader to the far left or the far right while pressing the [SHIFT] button in pause mode.

#### 2 Move the crossfader to the far-left or far-right position.

Set the crossfader to the far end of the channel to be used with the fader start function.

#### 3 Move the crossfader to the opposite direction while pressing the [SHIFT] button.

Playback of the track starts from the set cue point.

- When the crossfader is returned to the original position while pressing the [SHIFT] button during playback, the track moves instantaneously back to the set cue point and pause mode is set (Back Cue). If a cue point is not set, playback starts from the beginning of the track.

When the crossfader is moved from the left edge to the right edge (or from the right edge to the left edge) while pressing the [SHIFT] button when a cue is in standby, playback starts from the set cue point.

## Using effects

This product is equipped with two types of effect functions, BEAT FX and SOUND COLOR FX.

For details on operating these effects using the performance pads, see *Using the pad FX* (p.18).

## Using the BEAT FX function

You can set various effects according to the tempo (BPM = Beats Per Minute) of the track currently playing using the BEAT FX function.

### Main display



1	Effect name	Displays the name of the selected effect.
2	AUTO (TAP)	When the BPM measurement mode is auto mode, [AUTO] is displayed. When it is manual input mode, [TAP] is displayed.
3	BPM value display (3 digits)	Displays the automatically detected BPM in auto mode. If the BPM cannot be detected, the previously detected BPM value flashes. Displays the manually input BPM value in manual input mode.
4	Beat/parameter display section	Displays the selected number of beats. Displays parameters when the [BEAT ◀, ▶] buttons are pressed for some effects. Blinks when outside the parameter limits.
5	Selected channel display section	Displays the channel to which the effect is to be applied. Displays SP (SAMPLER), MIC, CH 1, CH 2, CH 3, CH 4, or MST (MASTER), depending on what is selected.

#### 1 Press the [BEAT ◀] or [BEAT ▶] button while pressing the [SHIFT] button.

Select the BPM measurement mode.

- [AUTO]: Press the [BEAT ◀] button while pressing the [SHIFT] button. The BPM is automatically measured from the input audio signal.
- [TAP]: Press the [BEAT ◀] button while pressing the [SHIFT] button. Enter the BPM manually. For information on manual input, refer to *Inputting the BPM manually* (p.21).

- The BPM measurement range for the [AUTO] setting is 70 to 180. BPM cannot be correctly measured for some tracks. If the BPM cannot be measured, the BPM value on the display flashes. In such cases, use the [TAP] button to input the BPM manually.

#### 2 Rotate the [BEAT FX SELECT] control.

Selects the type of effect.

- For information on the types of effects, refer to *Types of BEAT FX* (p.22).

#### 3 Rotate the [BEAT FX CH SELECT] control.

Selects the channel to apply the effect to.

- [SP]: Applies the effect to the sound of [SAMPLER] for rekordbox.
- [MIC]: Applies the effect to the sound of the [MIC] channel.
- [1] – [4]: Applies the effect to the sound of the respective channel.
- [MST]: Applies the effect to the sound of the [MASTER] channel.

#### 4 Press the [BEAT ◀, ▶] button.

Set the beat fraction to synchronize the effect sound with.

The effect time corresponding to the beat fraction is set automatically.

#### 5 Press the [BEAT FX ON/OFF] button.

The effect is applied to the sound.

The effect's quantitative parameter can be adjusted by turning the [BEAT FX LEVEL/DEPTH] control.

The [ON/OFF] button flashes when the effect is on.

- Press the [ON/OFF] button again to turn the effect off.

## Inputting the BPM manually

**While pressing the [SHIFT] button, tap the [BEAT ▶] button more than two times with your finger in time with the beat (quarter notes) of the sound being played.**

The average value of the interval that the [BEAT ▶] button is tapped while the [SHIFT] button is pressed is displayed in the BPM (EFFECT) display section.

- You can return to AUTO mode, press the [BEAT ◀] button while pressing the [SHIFT] button.

## Types of BEAT FX

### LOW CUT ECHO<sup>1</sup>

A delayed sound with the low frequency range reduced is output several times and gradually attenuated according to the beat fraction set with the [BEAT ◀, ▶] buttons.

- Lowering the channel faders and cutting the input volume leaves an echo sound, producing a fade out.

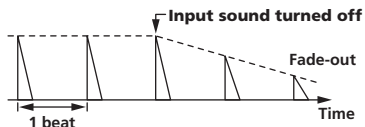

**BEAT ◀, ▶** buttons Sets the delay time between **1/16** and **16** beats with respect to 1 beat of BPM time.

**LEVEL/DEPTH** control Sets the balance between the original sound and the echo sound.

### ECHO<sup>1</sup>

A delayed sound is output several times and gradually attenuated according to the beat fraction set with the [BEAT ◀, ▶] buttons.

- Lowering the channel faders and cutting the input volume leaves an echo sound, producing a fade out.

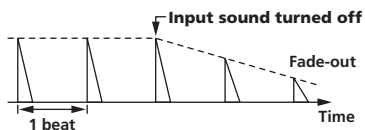

**BEAT ◀, ▶** buttons Sets the delay time between **1/16** and **16** beats with respect to 1 beat of BPM time.

**LEVEL/DEPTH** control Sets the balance between the original sound and the echo sound.

### MULTI TAP DELAY<sup>1</sup>

A delayed sound is output up to 7 times in 1/8 beat intervals according to the beat fraction set with the [BEAT ◀, ▶] buttons.

- Lowering the channel faders and cutting the input volume leaves a delayed sound.

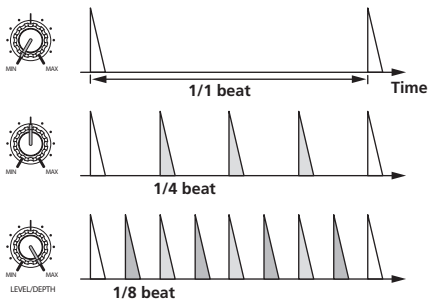

**BEAT ◀, ▶** buttons Sets the effect time between **1/16** and **16** beats with respect to 1 beat of BPM time.

**LEVEL/DEPTH** control Sets the volume to an odd-number delay from the [MIN] position to the center position, and an even-number delay from the center position to the [MAX] position.

### SPIRAL<sup>1</sup>

A reverberation effect is applied to the input sound. The pitch changes simultaneously if the delay time is changed.

- Lowering the channel faders and cutting the input volume leaves an effect sound.

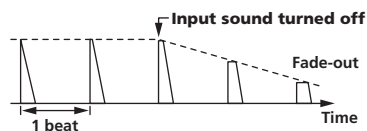

**BEAT ◀, ▶** buttons Sets the delay time between **1/16** and **16** beats with respect to 1 beat of BPM time.

**LEVEL/DEPTH** control Sets feedback, and the balance between the original sound and the effect sound.

### REVERB<sup>1</sup>

A reverberation effect is applied to the input sound.

- Lowering the channel faders and cutting the input volume leaves a delay sound.

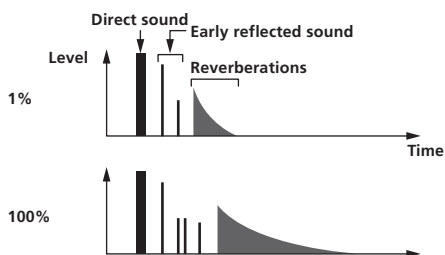

**BEAT ◀, ▶** buttons Sets the extent of the reverberation effect between **1** and **100** %.

**LEVEL/DEPTH** control Sets the balance between the original sound and the effect sound.

### TRANS

The sound is cut according to the beat fraction set with the [BEAT ◀, ▶] buttons.

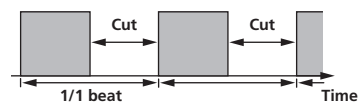

**BEAT ◀, ▶** buttons Sets the beat fraction between **1/16** and **16** with respect to 1 beat of BPM time.

**LEVEL/DEPTH** control Sets the duty ratio and balance between the original sound and effect sound.

### ENIGMA JET

A flanger effect is produced according to the beat fraction set with the [BEAT ◀, ▶] buttons. The pitch sounds as if it continues to ascend or descend.

**BEAT ◀, ▶** buttons Sets the beat fraction between **1/16** and **64** beats or between **-64** and **-1/16** beats, with respect to 1 beat of BPM time. The pitch ascends for beat fractions between **1/16** and **64** beats. The pitch descends for beat fractions between **-64** and **-1/16**.

**LEVEL/DEPTH** control The further the control is turned clockwise, the more the effect is stressed. When turned all the way counterclockwise, only the original sound is output.

## FLANGER

A 1-cycle flanger effect is produced according to the beat fraction set with the [BEAT ◀, ▶] buttons.

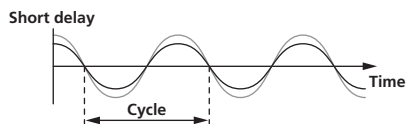

<b>BEAT</b> ◀, ▶ buttons	Sets the effect time between <b>1/16</b> and <b>64</b> beats with respect to 1 beat of BPM time.
<b>LEVEL/DEPTH</b> control	The further the control is turned clockwise, the more the effect is stressed. When turned all the way counterclockwise, only the original sound is output.

## PHASER<sup>1)</sup>

The phaser effect changes according to the beat fraction set with the [BEAT ◀, ▶] buttons.

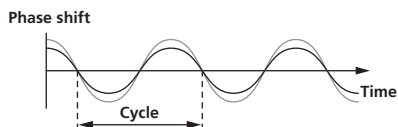

The phaser effect changes according to the beat button fraction.

<b>BEAT</b> ◀, ▶ buttons	Sets the cycle for moving the phaser effect with respect to 1 beat of BPM between <b>1/16</b> and <b>64</b> beats.
<b>LEVEL/DEPTH</b> control	The further the control is turned clockwise, the more the effect is stressed. When turned all the way counterclockwise, only the original sound is output.

## PITCH

The pitch of the source sound is changed.

<b>BEAT</b> ◀, ▶ buttons	Sets the pitch of the effect sound between <b>-50</b> and <b>100%</b> . <b>-50 to 100 (%)</b>
<b>LEVEL/DEPTH</b> control	Sets the pitch of the effect sound. When rotated all the way counterclockwise, the setting returns to the pitch of the original sound.

## SLIP ROLL

The sound being input at the point when the [ON/OFF] button is pressed is recorded, and the recorded sound is output repeatedly according to the beat fraction set with the [BEAT ◀, ▶] buttons. When the effect time changes, the input sound is recorded again.

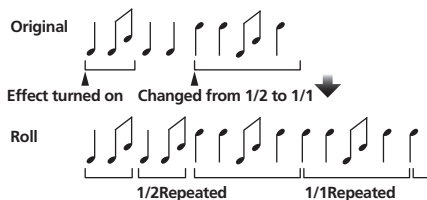

<b>BEAT</b> ◀, ▶ buttons	Sets the effect time between <b>1/16</b> and <b>16</b> beats with respect to 1 beat of BPM time.
<b>LEVEL/DEPTH</b> control	Sets the balance between the original sound and <b>ROLL</b> .

## ROLL

The sound being input at the point when the [ON/OFF] button is pressed is recorded, and the recorded sound is output repeatedly according to the beat fraction set with the [BEAT ◀, ▶] buttons.

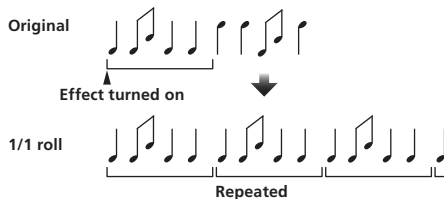

<b>BEAT</b> ◀, ▶ buttons	Sets the effect time between <b>1/16</b> and <b>16</b> beats with respect to 1 beat of BPM time.
<b>LEVEL/DEPTH</b> control	Sets the balance between the original sound and <b>ROLL</b> .

## MOBIUS (SAW)

Sawtooth wave sound is produced according to the beat fraction set with the [BEAT ◀, ▶] buttons. The pitch sounds as if it continues to ascend or descend.

This sound is mixed with the input sound, and the resulting sound is output. Oscillation is possible even if sound is not input.

<b>BEAT</b> ◀, ▶ buttons	Sets the beat fraction between <b>1/16</b> and <b>64</b> beats or between <b>-64</b> and <b>-1/16</b> beats, with respect to 1 beat of BPM time. The pitch ascends for beat fractions between <b>1/16</b> and <b>64</b> beats. The pitch descends for beat fractions between <b>-64</b> and <b>-1/16</b> .
<b>LEVEL/DEPTH</b> control	Adjusts the volume of the sawtooth wave sound to be mixed.

## MOBIUS (TRI)

Triangular wave sound is produced according to the beat fraction set with the [BEAT ◀, ▶] buttons. The pitch sounds as if it continues to ascend or descend.

This sound is mixed with the input sound, and the resulting sound is output. Oscillation is possible even if sound is not input.

<b>BEAT</b> ◀, ▶ buttons	Sets the beat fraction between <b>1/16</b> and <b>64</b> beats or between <b>-64</b> and <b>-1/16</b> beats, with respect to 1 beat of BPM time. The pitch ascends for beat fractions between <b>1/16</b> and <b>64</b> beats. The pitch descends for beat fractions between <b>-64</b> and <b>-1/16</b> .
<b>LEVEL/DEPTH</b> control	Adjusts the volume of the sawtooth wave sound to be mixed.

<sup>1)</sup> When [1] to [4] is selected with the effect channel selector switch, the effect sound cannot be monitored even if the [CUE] button of the selected channel is pressed.

## Using the SOUND COLOR FX function

These effects change in association with the [COLOR] controls for the different channels.

When the unit is connected with rekordbox dj, the SOUND COLOR FX function of rekordbox dj can be used.

The SOUND COLOR FX function of the unit can be used with external input.

### 1 Press a [SOUND COLOR FX SELECT] button.

Selects the type of effect.

The pressed button flashes.

- If a [SOUND COLOR FX SELECT] button is pressed when a [SOUND COLOR FX SELECT] button is already selected, the newly pressed button is selected.
- The same effect is set for all channels.

### 2 Rotate the [COLOR] control.

The effect is applied to the channel for which the control is rotated.

## Canceling the SOUND COLOR FX effect

### Press the flashing [SOUND COLOR FX SELECT] button.

The effect is canceled.

## Types of SOUND COLOR FX effects

rekordbox dj supports various SOUND COLOR FX.

When the software is used with the unit **DUB ECHO**, **PITCH**, **NOISE** and **FILTER** are selected by default.

Effects other than these can be used by changing the SOUND COLOR FX settings in rekordbox dj.

Switch SOUND COLOR FX of rekordbox dj to the [USER] mode to change the SOUND COLOR FX setting. You can set each effect to the desired effect.

Effect name	Descriptions	[COLOR] control
<b>DUB ECHO</b>	Outputs delayed sounds repeatedly after the original sound and gradually attenuates the delayed sounds to achieve an echo effect.	Turn counterclockwise: Applies the echo effect to the mid-range only. Turn clockwise: Applies the echo effect to the high-range only.
<b>PITCH</b>	Changes the sound pitch.	Turn counterclockwise: The pitch descends. Turn clockwise: The pitch rises.
<b>NOISE</b>	White noise generated inside this unit is mixed in to the sound of the channel via the filter and output.	Turn counterclockwise: Gradually decreases the cut-off frequency of the filter through which the white noise passes. Turn clockwise: Gradually increases the cut-off frequency of the filter through which the white noise passes.
<b>FILTER</b>	Outputs sound that has passed through a filter.	Turn counterclockwise: Gradually decreases the low-pass filter's cut-off frequency. Turn clockwise: Gradually increases the high-pass filter's cut-off frequency.

## Using a microphone

### 1 Connect a microphone to the [MIC1] input terminal or the [MIC2] input terminal.

### 2 Set the [OFF, ON, TALK OVER] selector switch to [ON] or [TALK OVER].

- [ON]: The indicator lights up.
- [TALK OVER]: The indicator flashes.
- When set to [TALK OVER], the sound of channels other than the [MIC1] channel and the [MIC2] channel is attenuated by -18 dB (default) when a sound of -10 dB or greater is input to the microphone.
- The level of attenuation applied when [TALK OVER] is selected can be changed in the utility screen. For information on how to change this setting, refer to *Microphone Talkover Level setting* (p.27).
- The talkover mode can be switched between normal mode and advanced mode. For information on how to change this setting, refer to *Microphone Talkover Mode setting* (p.27).

### 3 Rotate the [MIC1 LEVEL] or [MIC2 LEVEL] control.

Adjusts the level of sound output from the [MIC1] channel or the [MIC2] channel.

- The sound is output at a loud volume if the control is rotated to the extreme right.

### 4 Input audio to the microphone.

## Adjusting the sound quality

### Rotate the [EQ (HI and LOW)] controls.

- [HI]: -12 dB to +12 dB (10 kHz)
- [LOW]: -12 dB to +12 dB (100 Hz)

## Using MIC FX

### 1 Select the [MIXER/MIC] check box on rekordbox dj.

The MIC FX graphical user interface is displayed on rekordbox dj.

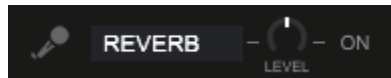

### 2 Adjust [LEVEL] on rekordbox dj.

### 3 Click the [ON] button on rekordbox dj.

The REVERB effect is applied to the MIC sound.

The MIC FX effect is fixed to REVERB.

## Quitting MIC FX

### Click the [ON] button for MIC FX on rekordbox dj.

MIC FX is canceled.

The MIC FX effect is also canceled if rekordbox is disconnected when the effect is being applied.



## Using external inputs

This unit is equipped with four sets of external inputs for connecting CD players, analog turntables, etc. The 4-channel mixer of this unit can be used to mix input sound without passing through a computer.



### Notes

- For details on the respective items, see *Connections* (p.14) and *Part names and functions* (p.5).
- The functions of rekordbox dj cannot be used for external input.
- The values adjusted with the various controls for rekordbox dj differ from the values adjusted with the various controls for external input.

---

## Mixing the sound of a DJ player, etc.

- 1 Connect a DJ player or other line level output device to the [LINE] input terminal or the [LINE/PHONO] input terminal.
- 2 Set the [LINE/PHONO] switch on the rear panel of this unit to [LINE].
- 3 Set the [USB A, LINE, USB B] selector switch or the [USB A, PHONO/LINE, USB B] selector switch on the top panel of this unit to [LINE] or [PHONO/LINE].
- 4 Adjust the level of sound output from each channel with the [TRIM] control and channel fader.

---

## Mixing the sound of an analog turntable, etc.

- 1 Connect an analog player or other phono level (for MM cartridges) output device to the [LINE/PHONO] input terminals of CH3 or CH4.
  - CH1 and CH2 are input terminals for [LINE] only.
  - Connect the ground wire of an analog player to the [SIGNAL GND] terminal of this unit.
- 2 Set the [LINE/PHONO] switch on the rear panel of this unit to [PHONO].
- 3 Set the [USB A, PHONO/LINE, USB B] switch on the top panel of this unit to [PHONO/LINE].
- 4 Adjust the level of sound output from each channel with the [TRIM] control and channel fader.

---

## Using SOUND COLOR FX with external input

The four **SOUND COLOR FX SELECT** types the unit can be used with external input.

For how to use **SOUND COLOR FX SELECT**, see *Using the SOUND COLOR FX function* (p.24).

The volume when the **NOISE** effect is used depends on the [TRIM] control of each channel.

---

---

# Changing the settings

---

---

## Launching utilities mode

If utilities mode is launched while the unit and a computer are connected by a USB cable, the set status may not be displayed properly.

The "MIDI Controller Settings" can be set in the utilities mode. This unit automatically switches operation as shown below depending on whether or not rekordbox dj is running.

- When rekordbox is running, controller operation depends on the rekordbox dj functions.
- When rekordbox dj is not running, this controller operates as a general MIDI controller.

Even if rekordbox dj is running, this controller can forcibly be operated as a general MIDI controller.

### 1 Disconnect the USB cable from the computer.

### 2 Press the [⏻] switch on the rear panel of this unit to set the unit to standby.

This unit enters standby mode.

### 3 While pressing both the [SHIFT] and [PLAY/PAUSE ►/II] buttons on the left deck, press the [⏻] switch on the rear panel of this unit.

Utilities mode is launched.

### 4 Press the [SLIP REVERSE] button on the left deck.

- [SLIP REVERSE] button (not lit): Automatically switches operation depending on whether or not rekordbox is running.
- [SLIP REVERSE] button (lit): Forcibly operates as a general MIDI controller regardless of whether or not rekordbox is running.

### 5 Press the [⏻] switch on the rear panel of this unit to set the unit to standby.

To save the settings, set the [⏻] switch on the rear panel of this unit to standby and quit utilities mode.

---

---

## Changing the settings with rekordbox

The settings required for the DJ player can be changed with rekordbox. Change the setting items in [Controller] of [Preferences].

- The following settings can be changed only when rekordbox and this unit are connected.

---

## Setting items in the [Deck] tab of [Controller]

### ❖ Ring Brightness setting

Sets the brightness of the JOG RING illumination.

You can switch the setting from a level of 1 to 3. The jog ring does not illuminate when set to Off.

- Set to 1 for the darkest illumination, and 3 for the brightest illumination.

### ❖ Jog > Brightness of the display setting

Sets the brightness of the jog display section.

5 levels from 1 to 5 are available for this setting.

- Set to 1 for the darkest illumination, and 5 for the brightest illumination.

### ❖ Display setting for the jog display

You can change the information displayed in the jog display section.

#### Display Artwork

When the [Display Artwork] check box is selected, the display is enabled and the artwork for the track loaded from rekordbox is displayed on the jog display.

#### Display CUE SCOPE

When the [Display CUE SCOPE] check box is selected, the display is enabled and the CUE SCOPE is displayed on the jog display.

#### Time Mode

The information displayed for the time display can be switched with [Time Mode].

- **Elapsed:** With 0:00 as the starting point of the track, displays the time elapsed from the beginning to the current playback position.
- **Remaining:** With 0:00 as the end of the track, displays the time remaining to the end from the current playback position.

### ❖ Slip Mode Flashing

Changes the slip mode flashing setting.

- **Enable:** The buttons that can be operated only while slip mode is on flash (the [HOT CUE] button, the [4 BEAT LOOP/EXIT] button, etc.).
- **Disable:** The buttons that can be operated only while slip mode is on do not flash.

### ❖ Slip button LED while slip mode is on

Sets the lighting operation of the [SLIP] button for when slip mode is on.

- **Light is On:** The [SLIP] button lights up when slip mode is on, and flashes while slip mode is being operated.
- **Blink:** The [SLIP] button does not light up when slip mode is on.

---

## Setting items in the [Mixer] tab of [Controller]

### ❖ Fader Start setting

Changes the fader start function setting.

- By default, this is enabled.

When the [Activate the fader start when moving a channel fader or the cross fader while pressing the SHIFT button.] check box is selected, the function is enabled.

### ❖ Cross Fader Curve setting

Switches the characteristics of the crossfader curve.

- The further the control is turned clockwise, the sharper the curve rises.
- The further the control is turned counterclockwise, the more gradually the curve rises.

### ❖ Cross Fader Cut Lag setting

Adjust the play (cut lag) of both ends of the crossfader.

Adjustment can be made from 0.3 mm to 5.5 mm in 0.1 mm increments.

- By default, the level is set to 1.0 mm.

### ❖ Output setting of the microphone to the booth monitor

Changes whether or not the microphone sound is output from the booth channel.

When the [Mic Output On Booth] check box is unselected, the microphone sound is output from the booth channel. When the check box is selected, the microphone sound is not output from the booth channel.

### ❖ Mixer > Brightness of the display setting

Sets the brightness of the mixer display section.

3 levels from 1 to 3 are available for this setting.

Set to 1 for the darkest illumination, and 3 for the brightest illumination.

### ❖ Microphone Talkover Mode setting

Switches the talkover mode.

- **Advanced Talkover Mode:** Sound from channels other than the microphone channel is output with only the mid-range attenuated according to the talkover level setting.

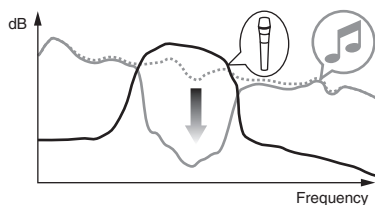

- **Normal Talkover Mode:** Sound from channels other than the microphone channel is output with the sound attenuated according to the talkover level setting.

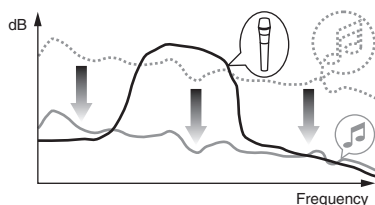

### ❖ Microphone Talkover Level setting

Sets the talk over function's sound attenuation level.

Setting values: -6 dB / -12 dB / -18 dB / -24 dB

## Setting items of [DDJ-1000] tab in [Controller]

### ❖ Master Attenuator Level setting

Sets the master output attenuator level.

Setting values: 0 dB / -6 dB / -12 dB

### ❖ Monaural/Stereo Selection for Master Output

Switches the monaural/stereo setting for the master output sound.

- **Monaural:** Outputs the master sound in monaural.
- **Stereo:** Outputs the master sound in stereo.

### ❖ Booth Attenuator Level setting

Sets the booth output attenuator level.

Setting values: 0 dB / -6 dB / -12 dB

### ❖ Monaural/Stereo Selection for Booth Output

Switches the monaural/stereo setting for the booth output sound.

- **Monaural:** Outputs the booth sound in monaural.
- **Stereo:** Outputs the booth sound in stereo.

### ❖ Peak Limiter setting for Master Output

Lessens sudden, unpleasant digital clipping of the master output.

- **Enable:** Enables the peak limiter for master output.
- **Disable:** Disables the peak limiter for master output.

### ❖ Microphone sound limiter setting added to Master Output

Lessens sudden, unpleasant digital clipping of the microphone sound that is added to the master output.

- **Enable:** Enables the peak limiter
- **Disable:** Disables the peak limiter

### ❖ Microphone sound limiter setting added to Booth Output

Lessens sudden, unpleasant digital clipping of the microphone sound that is added to the booth output.

- **Enable:** Enables the peak limiter
- **Disable:** Disables the peak limiter

### ❖ SHIFT Function List setting

Changes the display setting for the **SHIFT** function list.

- By default, this is enabled.

When the [Display SHIFT Function List while pressing the SHIFT button.] check box is selected, the **SHIFT** function list is displayed on rekordbox while the [SHIFT] button is pressed.

### ❖ Demo/Screen saver setting

Sets the screen saver function and the time for when to start demo mode.

- By default, demo mode starts when there is no operation for 10 minutes.
- Demo mode is canceled if any of the controls or buttons of the unit are operated during demo mode.
- When the screen saver function is enabled, it starts up when there is no operation for 30 minutes.
- **Demo (1 minute):** Demo mode starts when there is no operation on this unit for 1 minute.
- **Demo (5 minutes):** Demo mode starts when there is no operation on this unit for 5 minutes.
- **Demo (10 minutes):** Demo mode starts when there is no operation on this unit for 10 minutes.
- **Screen saver:** Enables the screen saver function.
- **Disable:** Demo mode and the screen saver function do not start.

### ❖ Auto Standby setting

Changes the auto standby function setting.

When this setting is enabled, this unit enters standby automatically after 4 hours if any of the following conditions are met.

- None of this unit's buttons or controls are operated.
- No audio signal of -18 dB or greater is input to an input terminal of this unit.
- Standby status is canceled when the [QUANTIZE] button on the left deck is pressed.

## Setting utility software

The setting utility can be used to perform the checks and settings described below.

- Adjusting the buffer size (when ASIO is used)
- Checking the version of the driver software

## Displaying the setting utility

### For Mac

Click [Macintosh HD] icon > [Application] > [Pioneer] > [DDJ-1000] > [DDJ-1000 driver version display utility].

### For Windows 10

Click [Pioneer] > [DDJ-1000 Settings Utility] from the [Start] menu.

### For Windows 8.1

From [Apps view], click [Pioneer] > [DDJ-1000 Settings Utility].

### For Windows 7

Click [All Programs] > [Pioneer] > [DDJ-1000] > [DDJ-1000 Settings Utility] from the Windows [Start] menu.

## Adjusting the buffer size (when ASIO is used)

This function can only be used by those using a Windows operating system.

If an application using this unit as the default audio device (DJ software, etc.) is running, quit the application before adjusting the buffer size. Display the setting utility before starting.

### ● Click the [ASIO] tab.

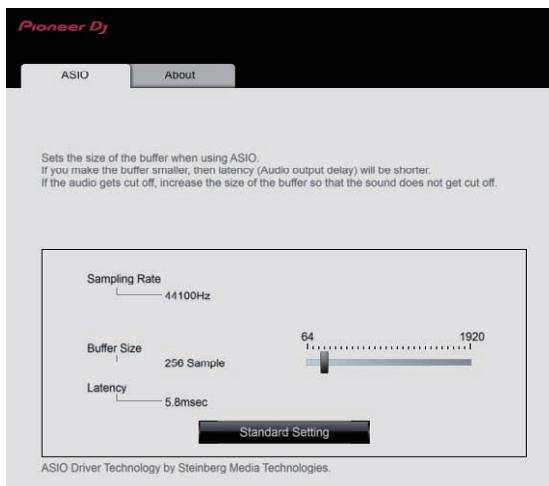

- If a large buffer size is set, drops in audio data (breaks in the sound) occur less easily, but the time lag due to the delay in the transfer of the audio data (latency) increases.

## Checking the version of the driver software

Display the setting utility before starting.

### ● Click the [About] tab.

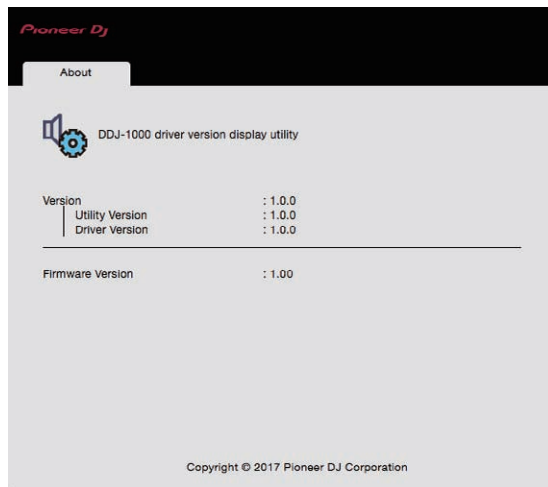

- You can check the firmware version of this unit on the screen.
- The firmware version is not displayed when this unit is not connected to the computer or when this unit and computer are not properly communicating.

# Additional information

## Troubleshooting

- If you think that there is something wrong with this unit, access the Pioneer DJ support site and check [FAQ].  
pioneerdj.com/support/  
Some problems occur due to the connected components. If the problem cannot be resolved after checking the connected components, contact the service center or your dealer for repairs.
- The player may not operate properly due to static electricity or other external influences. In such cases, normal operation may become possible if you turn the power off and then back on.

Problem	Check	Remedy
The unit does not turn on.	Is the [⏻] switch of the power on the rear panel of the unit on?	Turn on the [⏻] switch.
	Is the included AC adapter properly connected?	Connect the included AC adapter correctly.
The unit is not recognized.	Is the included USB cable properly connected?	Connect the included USB cable properly.
	Are you using a USB hub?	USB hubs cannot be used. Connect the computer and this unit directly using the included USB cable.
	Is the driver software properly set?	Set the driver software properly. (Page 31)
	Is your computer recognizing the unit?	Windows: Check if the firmware version of this unit is displayed on the [About] tab of [DDJ-1000 Settings Utility]. (page 28) Mac: Check if the firmware version of this unit is displayed on the [About] tab of [DDJ-1000 driver version display utility]. (page 28)
	Are other applications running?	Quit the other applications including screen savers and resident software. (When quitting antivirus security software, before doing so, disable the Internet connection to ensure the security of your computer.)
	Are USB devices other than this unit connected?	Remove external hard disks and the keyboard (for some models), etc. to check the status with only the built-in hard disc.
	—	If your computer has more than one USB terminal, check using a different USB terminal.
	Are multiple ASIO drivers for units other than this unit installed on the computer?	Uninstall unnecessary ASIO drivers. For details on how to uninstall ASIO drivers, check with the manufacturer of the respective ASIO driver.
	Is the sound setting on the computer set properly?	Mac: Disconnect the USB cable connecting the unit and the computer, launch [Audio MIDI Setup] (the utility software for macOS or OS X), and the [MIDI Window] or [MIDI studio] will be displayed. Select the [DDJ-1000] icon, and click [Remove Device]. (The [USB MIDI Device] icon may be displayed instead of the [DDJ-1000] icon. In that case, select [USB MIDI Device].) If this unit is connected to the computer using the USB cable again, the [DDJ-1000] icon will appear.
Sound is not output, or sound is too small.	Are the [TRIM] control, the channel fader, the cross fader, the [USB A, PHONO/LINE, USB B] selector switch (or the [USB A, LINE, USB B] selector switch), the [LINE/PHONO] switch and the [MASTER LEVEL] control set to the proper positions?	Set the [TRIM] control, the channel fader, the cross fader, the [USB A, PHONO/LINE, USB B] selector switch (or the [USB A, LINE, USB B] selector switch), the [LINE/PHONO] switch and the [MASTER LEVEL] control to the proper positions.
	Are the connected powered speakers, etc., properly set?	Properly set the external input selection, volume, etc., on the powered speakers, etc.
	Are the connection cables properly connected?	Connect the connection cables properly.
	Are the terminals and plugs dirty?	Clean the terminals and plugs before connecting them to the unit.
	Is the driver software properly set?	Set the driver software properly. (Page 31)
Sound is distorted.	Is the [MASTER LEVEL] control set to the proper position?	Adjust the [MASTER LEVEL] control to confirm that the master level indicator lights up in orange at the highest volume.
	Is the [TRIM] control set to the proper position?	Adjust the [TRIM] control so that the channel level indicator lights up in orange at the peak level.
	Is the [LINE/PHONO] switch set to the proper position?	Set the [LINE/PHONO] switch to the proper position.
Sound is interrupted when the DJ software is used.	Is the buffer size (latency) value appropriate?	On a Windows operating system, use the setting utility to set an appropriate buffer size value. (page 28) On a Macintosh, set the appropriate buffer size (latency) value for the DJ software.
Cannot output the microphone sound.	Are the [OFF, ON, TALK OVER] selector switches set to the proper position?	Set the [OFF, ON, TALK OVER] selector switches to the proper position.
Cannot output the sound of the external device.	Is the [USB A, PHONO/LINE, USB B] selector switch (or the [USB A, LINE, USB B] selector switch) set to the proper position?	Set the [USB A, PHONO/LINE, USB B] selector switch (or the [USB A, LINE, USB B] selector switch) to the proper position.
Sound is interrupted when the ASIO driver is set.	Has the ASIO driver been set with rekordbox running?	Set the ASIO driver before launching rekordbox. (page 28)

Problem	Check	Remedy
The indicator flashes and operation is strange.	—	Normal operation can be restored by disconnecting the AC adapter, waiting at least 1 minute, and then reconnecting the AC adapter. If the same symptom persists, disconnect the AC adapter, and then make a request for repairs.
Operation of rekordbox dj becomes unstable.	Are you using the latest version of the software?	Free updates of rekordbox can be downloaded from the website. Use the most recent version. (page 4)
	Are you using software other than rekordbox at the same time?	Quit the other applications to decrease the load on the computer. If operation continues to be unstable, try disabling the wireless network or other wireless connections, antivirus software, the screen saver, the low power mode, etc. (page 3)
	Are there other USB devices connected to the computer?	Disconnect the other USB devices from the computer. When another USB audio device is connected to the computer at the same time, this unit may not operate or be recognized normally.
	Are you using a USB hub?	USB hubs cannot be used. Connect the computer and this unit directly using the included USB cable.
	Is there a problem with the USB port to which this unit is connected?	If your computer has multiple USB ports, try connecting this unit to a different USB port.
	Is this unit connected to a notebook computer running on its battery?	Supply power to the notebook computer from an AC power supply. (Depending on the notebook computer's settings, low power mode may be set when the computer is running on its battery, automatically reducing the performance of the computer itself.) (page 3)
	Is the USB buffer size too small?	Raise the USB buffer size. (page 28)
The jog dial illumination does not turn during playback. (It does turn when scratching.) The <b>[TEMPO]</b> slider does not work when the deck is switched during <b>BEAT SYNC</b> .	Is the utility mode setting correct?	In utility mode, check that the unit is not set to be forcefully operated as a general MIDI controller. (page 26)
The fader start function does not work.	Is a cue set?	Set a cue. (page 21)
	Is the fader start setting incorrect?	To enable the fader start setting, select the <b>[Mixer]</b> tab of <b>[Preferences]</b> > <b>[Controller]</b> in rekordbox and then select the [Fader Start] check box. (page 26)
Only one track deck is display on the screen. The platter is not displayed on the track deck.	Is rekordbox set to <b>[EXPORT]</b> mode?	Click the area indicated by <b>[EXPORT]</b> at the upper left of the screen, and then select <b>[PERFORMANCE]</b> .
	Has rekordbox dj been activated?	Enter the rekordbox dj license key included with this unit on the <b>[Preferences]</b> > <b>[License]</b> screen of rekordbox. For details on how to activate the license key, see "rekordbox Introduction".
The sound of the sampler deck cannot be monitored with headphones.	Is <b>[SAMPLER CUE]</b> selected?	Press the <b>[SAMPLER CUE]</b> button to turn on the monitor of the sampler deck.
	Is the position of the <b>[SAMPLER VOL]</b> control still turned counterclockwise?	Set the <b>[SAMPLER VOL]</b> control to an appropriate position.

## Liquid crystal display

- Small black or shining points may appear on the liquid crystal display. This is a phenomenon inherent to liquid crystal displays; this is not a malfunction.
- When this unit is used in cold places, the liquid crystal display may be dark for a while after this unit is turned on. It will reach the normal brightness after a while.
- When the liquid crystal display is exposed to direct sunlight, the light will reflect off it, making it difficult to see. Block the direct sunlight.

# Signal flow

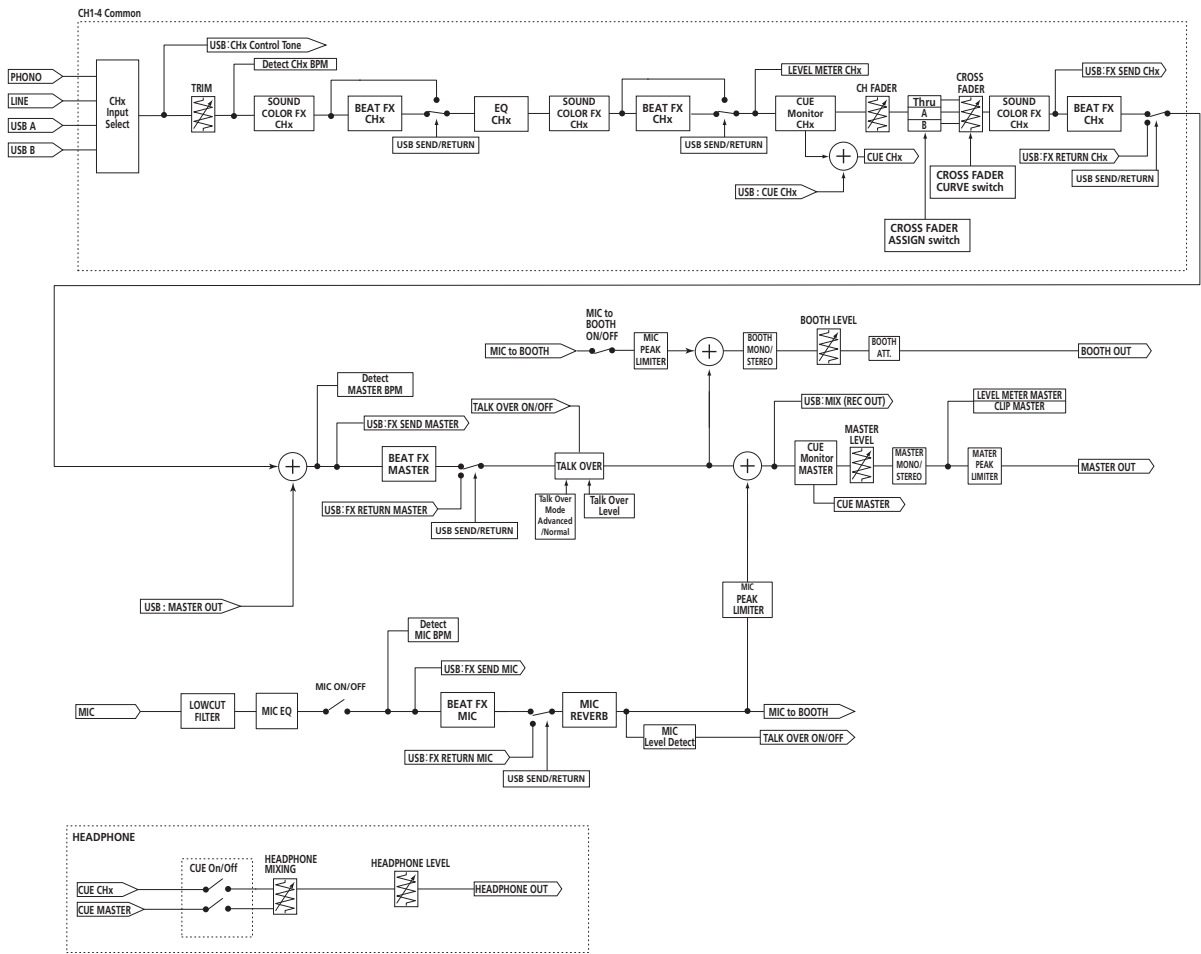

## Using this unit as a controller for other DJ software

This unit also outputs the operating data for the buttons and controls in MIDI format. If you connect a computer with built-in MIDI-compatible DJ software via a USB cable, you can operate the DJ software from this unit. The sound of music files being played on the computer can also be output from the DDJ-1000.

To use this unit as a controller to operate DJ software other than rekordbox, switch to the setting for using software other than rekordbox in the utilities screen. Also, set the DJ software's audio and MIDI related settings.

- For details, see your DJ software's operating instructions.

## MIDI messages

For details on the MIDI messages on this unit, see "List of MIDI Messages".

- "List of MIDI Messages" can be acquired from the following Pioneer DJ site.  
pioneerdj.com/

## Driver software

Dedicated driver software is required for outputting audio signals from a computer.

- First read the *Software end user license agreement* on page 32 carefully.

## Operating environment

### Supported operating systems

Mac: macOS High Sierra 10.13/Sierra 10.12 (latest update), OS X 10.11/10.10 (latest update)	✓
Windows: Windows® 10, Windows® 8.1, Windows® 7 (latest service pack)	32-bit version ✓ 64-bit version ✓

### ❖ Checking the latest information on the driver software

For the latest information on the dedicated driver software for this unit, see the following Pioneer DJ support site.

- [pioneerdj.com/](http://pioneerdj.com/)

## Obtaining the driver software

- 1 Launch a web browser on a computer and access the following Pioneer DJ site.  
[pioneerdj.com/](http://pioneerdj.com/)
- 2 Click [Support].
- 3 Click [Software & firmware updates].

4 Click [DDJ-1000] in the [DJ CONTROLLER] category.

5 After clicking [Drivers], download the latest driver software from the download page.

Download the driver software for either Mac or Windows from the download page.

---

## Installation (Mac)

Do not connect this unit and the computer until the installation is completed.

- Close all the applications running on the computer before installing the software.

1 Unzip the driver software for Mac (DDJ1000MXXXdmg.zip) downloaded in *Obtaining the driver software*.

2 Double-click [DDJ-1000\_M\_X.X.X.dmg].

3 Double-click [DDJ-1000AudioDriver.pkg].

The driver software installation screen appears.

4 Check the details on the screen and click [Continue Anyway].

5 When the end user license agreement appears, read the *Software end user license agreement* carefully, and then click [Continue Anyway].

6 If you consent to the provisions of the *Software end user license agreement*, click [Agree].

If you do not consent to the provisions of the *Software end user license agreement*, click [Disagree] and stop installation.

7 Complete the installation by following the instructions on the screen.

---

## Installation procedure (Windows)

Do not connect this unit and the computer until the installation is completed.

- Log in to the computer as the administrator before installation.
- Close all the applications running on the computer before installing the software.

1 Unzip the driver software for Windows (DDJ1000XXXexe.zip) downloaded in *Obtaining the driver software*.

2 Double-click [DDJ-1000\_X.XXX.exe].

The driver software installation screen appears.

3 Carefully read the *Software end user license agreement* and if you consent to the provisions, put a check mark in [I agree.] and click [OK].

If you do not consent to the provisions of the *Software end user license agreement*, click [Cancel] and stop installation.

4 Complete the installation by following the instructions on the screen.

If [Windows Security] appears on the screen while the installation is in progress, click [Install this driver software anyway] to continue the installation.

When the installation is completed, a completion message appears.

### ❖ Software end user license agreement

This Software End User License Agreement ("Agreement") is between you (both the individual installing the Program and any single legal

entity for which the individual is acting) ("You" or "Your") and Pioneer DJ Corporation ("Pioneer DJ").

TAKING ANY STEP TO SET UP OR INSTALL THE PROGRAM MEANS THAT YOU ACCEPT ALL OF THE TERMS OF THIS LICENSE AGREEMENT. PERMISSION TO DOWNLOAD AND/OR USE THE PROGRAM IS EXPRESSLY CONDITIONED ON YOUR FOLLOWING THESE TERMS. WRITTEN OR ELECTRONIC APPROVAL IS NOT REQUIRED TO MAKE THIS AGREEMENT VALID AND ENFORCEABLE. IF YOU DO NOT AGREE TO ALL OF THE TERMS OF THIS AGREEMENT, YOU ARE NOT AUTHORIZED TO USE THE PROGRAM AND MUST STOP INSTALLING IT OR UNINSTALL IT, AS APPLICABLE.

## 1 DEFINITIONS

- 1 "Documentation" means written documentation, specifications and help content made generally available by Pioneer DJ to aid in installing and using the Program.
- 2 "Program" means all or any part of Pioneer DJ's software licensed to You by Pioneer DJ under this Agreement.

## 2 PROGRAM LICENSE

- 1 Limited License. Subject to this Agreement's restrictions, Pioneer DJ grants to You a limited, non-exclusive, non-transferable, license (without the right to sublicense):
  - a To install a single copy of the Program in Your computer or mobile device, to use the Program only for Your personal purpose complying with this Agreement and the Documentation ("Authorized Use");
  - b To use the Documentation in support of Your Authorized Use; and
  - c To make one copy of the Program solely for backup purposes, provided that all titles and trademark, copyright and restricted rights notices are reproduced on the copy.
- 2 Restrictions. You will not copy or use the Program or Documentation except as expressly permitted by this Agreement. You will not transfer, sublicense, rent, lease or lend the Program, or use it for third-party training, commercial time-sharing or service bureau use. You will not Yourself or through any third party modify, reverse engineer, disassemble or decompile the Program, except to the extent expressly permitted by applicable law, and then only after You have notified Pioneer DJ in writing of Your intended activities.
- 3 Ownership. Pioneer DJ or its licensor retains all right, title and interest in and to all patent, copyright, trademark, trade secret and other intellectual property rights in the Program and Documentation, and any derivative works thereof. You do not acquire any other rights, express or implied, beyond the limited license set forth in this Agreement.
- 4 No Support. Pioneer DJ has no obligation to provide support, maintenance, upgrades, modifications or new releases for the Program or Documentation under this Agreement.

## 3 WARRANTY DISCLAIMER

THE PROGRAM AND DOCUMENTATION ARE PROVIDED "AS IS" WITHOUT ANY REPRESENTATIONS OR WARRANTIES, AND YOU AGREE TO USE THEM AT YOUR SOLE RISK. TO THE FULLEST EXTENT PERMISSIBLE BY LAW, PIONEER DJ EXPRESSLY DISCLAIMS ALL WARRANTIES OF ANY KIND WITH RESPECT TO THE PROGRAM AND DOCUMENTATION, WHETHER EXPRESS, IMPLIED, STATUTORY, OR ARISING OUT OF COURSE OF PERFORMANCE, COURSE OF DEALING OR USAGE OF TRADE, INCLUDING ANY WARRANTIES OF MERCHANTABILITY, FITNESS FOR A PARTICULAR PURPOSE, SATISFACTORY QUALITY, ACCURACY, TITLE OR NON-INFRINGEMENT.

## 4 EXPORT CONTROL AND COMPLIANCE WITH LAWS AND REGULATIONS

You may not use or otherwise export or re-export the Program except as authorized by United States law and the laws of the jurisdiction in which the Program was obtained. In particular, but without limitation, the Program may not be exported or re-exported (a) into any U.S.-embargoed countries or (b) to anyone on the U.S. Treasury Department's Specially Designated Nationals List or the U.S. Department of Commerce Denied Persons List or Entity List. By using the Program, you represent and warrant that you are not located in any such country or on any such list. You also agree that you will not use the Program for any purposes prohibited by United States law, including, without limitation, the development,



design, manufacture, or production of nuclear, missile, or chemical or biological weapons.

## 5 U.S. GOVERNMENT RESTRICTED RIGHTS

The Program and Documentations are "commercial computer software" and "commercial computer software documentation" as those terms are defined in 48 C.F.R. §252.227-7014 (a) (1) (2007) and 252.227-7014 (a) (5) (2007). The U.S. Government's rights with respect to the Program and Documentations are limited by this license pursuant to 48 C.F.R. §12.212 (Computer software) (1995) and 48 C.F.R. §12.211 (Technical data) (1995) and/or 48 C.F.R. §227.7202-3, as applicable. As such, the Program and Documentations are being licensed to the U.S. Government end users: (a) only as "commercial items" as that term is defined in 48 C.F.R. §2.101 generally and as incorporated in DFAR 212.102; and (b) with only those limited rights as are granted to the public pursuant to this license. Under no circumstance will the U.S. Government or its end users be granted any greater rights than we grant to other users, as provided for in this license. Manufacturer is Pioneer DJ Corporation, 6F, Yokohama i-Mark Place, 4-4-5 Minatomirai, Nishi-ku, Yokohama, Kanagawa, 220-0012 Japan

## 6 DAMAGES AND REMEDIES FOR BREACH

You agree that any breach of this Agreement's restrictions would cause Pioneer DJ irreparable harm for which money damages alone would be inadequate. In addition to damages and any other remedies to which Pioneer DJ may be entitled, You agree that Pioneer DJ may seek injunctive relief to prevent the actual, threatened or continued breach of this Agreement.

## 7 TERMINATION

Pioneer DJ may terminate this Agreement at any time upon Your breach of any provision. If this Agreement is terminated, You will stop using the Program, permanently delete it from your computer or mobile device where it resides, and destroy all copies of the Program and Documentation in Your possession, confirming to Pioneer DJ in writing that You have done so. Sections 2.2, 2.3, 2.4, 3, 4, 5, 6, 7 and 8 will continue in effect after this Agreement's termination.

## 8 GENERAL TERMS

- 1** Limitation of Liability. In no event will Pioneer DJ or its subsidiaries be liable in connection with this Agreement or its subject matter, under any theory of liability, for any indirect, incidental, special, consequential or punitive damages, or damages for lost profits, revenue, business, savings, data, use, or cost of substitute procurement, even if advised of the possibility of such damages or if such damages are foreseeable. In no event will Pioneer DJ's liability for all damages exceed the amounts actually paid by You to Pioneer DJ or its subsidiaries for the Program. The parties acknowledge that the liability limits and risk allocation in this Agreement are reflected in the Program price and are essential elements of the bargain between the parties, without which Pioneer DJ would not have provided the Program or entered into this Agreement.
- 2** The limitations or exclusions of warranties and liability contained in this Agreement do not affect or prejudice Your statutory rights as consumer and shall apply to You only to the extent such limitations or exclusions are permitted under the laws of the jurisdiction where You are located.
- 3** Severability and Waiver. If any provision of this Agreement is held to be illegal, invalid or otherwise unenforceable, that provision will be enforced to the extent possible or, if incapable of enforcement, deemed to be severed and deleted from this Agreement, and the remainder will continue in full force and effect. The waiver by either party of any default or breach of this Agreement will not waive any other or subsequent default or breach.
- 4** No Assignment. You may not assign, sell, transfer, delegate or otherwise dispose of this Agreement or any rights or obligations under it, whether voluntarily or involuntarily, by operation of law or otherwise, without Pioneer DJ's prior written consent. Any purported assignment, transfer or delegation by You will be null and void. Subject to the foregoing, this Agreement will be binding upon and will inure to the benefit of the parties and their respective successors and assigns.
- 5** Entire Agreement. This Agreement constitutes the entire agreement between the parties and supersedes all prior or contemporaneous agreements or representations, whether written or oral,

concerning its subject matter. This Agreement may not be modified or amended without Pioneer DJ's prior and express written consent, and no other act, document, usage or custom will be deemed to amend or modify this Agreement.

- 6** You agree that this Agreement shall be governed and construed by and under the laws of Japan.

## Trademarks and registered trademarks

- Pioneer DJ is a trademark of the PIONEER CORPORATION and is used under license.
- rekordbox is a trademark or registered trademark of the Pioneer DJ Corporation.
- Windows is a registered trademark of Microsoft Corporation in the United States and other countries.
- Mac, macOS, OS X, and Finder are trademarks of Apple Inc., registered in the U.S. and other countries.
- Intel and Intel Core are trademarks of Intel Corporation in the U.S. and/or other countries.
- ASIO is a trademark of Steinberg Media Technologies GmbH.

The names of companies and products mentioned herein are trademarks or registered trademarks of their respective owners.

This product has been licensed for nonprofit use. This product has not been licensed for commercial purposes (for profit-making use), such as broadcasting (terrestrial, satellite, cable or other types of broadcasting), streaming on the Internet, Intranet (corporate networks) or other types of networks or distributing of electronic information (online digital music distribution services). You need to acquire the corresponding licenses for such uses. For details, see <http://www.mp3licensing.com>.

## Cautions on copyrights

rekordbox restricts playback and duplication of copyright-protected music contents.

- When coded data, etc., for protecting the copyright is embedded in the music contents, it may not be possible to operate the program normally.
- When rekordbox detects that coded data, etc., for protecting the copyright is embedded in the music contents, processing (playback, reading, etc.) may stop.

Recordings you have made are for your personal enjoyment and according to copyright laws may not be used without the consent of the copyright holder.

- Music recorded from CDs, etc., is protected by the copyright laws of individual countries and by international treaties. It is the full responsibility of the person who has recorded the music to ensure that it is used legally.
- When handling music downloaded from the Internet, etc., it is the full responsibility of the person who has downloaded the music to ensure that it is used in accordance with the contract concluded with the download site.

— The specifications and design of this product are subject to change without notice.

© 2017 Pioneer DJ Corporation. All rights reserved.  
<DRI1516-A>