

# Partners Worldwide

 **GERMANY**  
MONACOR INTERNATIONAL  
GmbH & Co. KG

Zum Falsch 36  
28307 Bremen  
Germany

Phone: +49 421 4865-0  
Fax: +49 421 488415  
info@monacor.com  
www.monacor-international.de

 **ALGERIA**  
IHTIRAFI MEDIA SYSTEM

 **AZERBAIDZHAN**  
Best Comp Group

 **CZECH REPUBLIC**  
MONACOR SLOVAKIA spol. s r.o.

 **FINLAND**  
MONACOR NORDIC A/S

 **GREENLAND**  
MONACOR DANMARK A/S

 **ITALY**  
ZZIPP GROUP SPA

 **LITHUANIA**  
Scenos Servisas JSC  
Sintonas  
UAB Inseria

 **NORWAY**  
MONACOR NORGE

 **RUSSIA**  
BM Distribution  
OSC Distribution

 **SWEDEN**  
MONACOR SVERIGE AB

 **UKRAINE**  
LuxPRO, OptimalSound  
Raduga Svit, UKRTECH Ltd

 **UNITED KINGDOM**  
MONACOR UK Ltd

 **ANDORRA**  
MONACOR IBERIA, S.A.U.

 **BELARUS**  
MuzTorgServis Ltd

 **DENMARK**  
MONACOR DANMARK A/S

 **FRANCE**  
MONACOR FRANCE S.A.R.L.

 **HUNGARY**  
MONACOR HUNGÁRIA Kft.

 **KIRGHIZIA**  
Sound.KG

 **LUXEMBOURG**  
MONACOR BELGIUM BVBA

 **POLAND**  
MONACOR POLSKA Sp. z o.o.

 **SAN MARINO**  
ZZIPP GROUP SPA

 **SWITZERLAND**  
MONACOR SCHWEIZ AG

 **UNITED ARAB EMIRATES**  
Levels FZ LLC

 **ARMENIA**  
MCF Production LLC  
Four Stage LLC

 **BELGIUM**  
MONACOR BELGIUM BVBA

 **ESTONIA**  
EW Sound  
Hannu Pro Tallinn LLC  
Mulgikontsert OÜ

 **GEORGIA**  
Sound City

 **ICELAND**  
MONACOR DANMARK A/S

 **LATVIA**  
SGM SIA  
SIA Čivix

 **MONACO**  
MONACOR FRANCE S.A.R.L.

 **PORTUGAL**  
MONACOR IBERIA, S.A.U.

 **SLOVAKIA**  
MONACOR SLOVAKIA spol. s r.o.

 **TURKEY**  
KALEPRO

 **AUSTRIA**  
MONACOR INTERNATIONAL  
GmbH & Co. KG

 **BULGARIA**  
PRO AUDIO Ltd.  
Solton Music LTD

 **FAROE ISLANDS**  
MONACOR DANMARK A/S

 **GREECE**  
ABAS

 **IRELAND**  
MONACOR UK Ltd

 **LIECHTENSTEIN**  
MONACOR SCHWEIZ AG

 **NETHERLANDS**  
MONACOR NEDERLAND B.V.

 **ROMANIA**  
MONACOR ROMANIA SRL

 **SPAIN**  
MONACOR IBERIA, S.A.U.



# Our Service: Your Advantage

## Solutions with a clear quality assurance

Our proactive quality policy ensures most reliable products. Strict testing criteria within tight tolerance limits ensure the high quality and technical safety of our products. Extensive examination of the products at MONACOR INTERNATIONAL and our detailed instruction manuals are completed by the service of accredited test laboratories. Thus, all of our products meet highest quality requirements. You will clearly benefit from our 3-year warranty which applies to all of the products from MONACOR INTERNATIONAL.



## Targeted brand advertising to ensure your success

With targeted PR and marketing activities, we will strengthen user confidence in PA technology from the brand MONACOR. Thus, for example, product tests are thoroughly prepared and campaigns for online advertising or specialised magazines are precisely planned and implemented. And we will always have an open ear for your advertising campaigns and provide support during implementation.

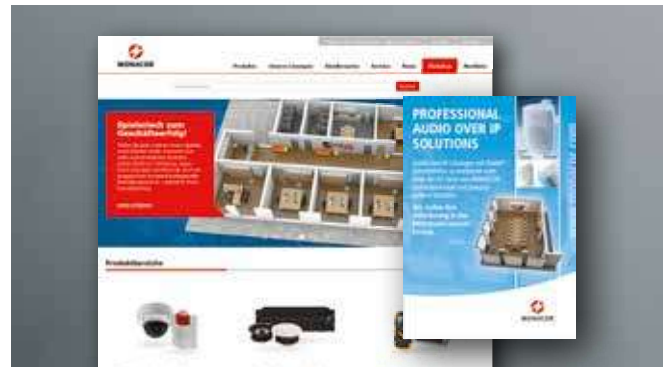

## Comprehensive and coordinated

With our impressive product variety from the ranges of Commercial Audio, Consumer Brands and Components, we ensure that our product portfolio perfectly meets your requirements. We are specialists in each of our product ranges. No matter whether PA technology from the brand MONACOR or the reliable stage and event technology from IMG STAGELINE, we know the trends. Our offer also includes matching accessories and electronic components which are tailor-made for the product ranges.



## Clever concepts

Technology develops at a speed which can surely be described as breathtaking. Our product experts travel worldwide to uncover latest trends and developments in order to offer you the latest in technology. That provides you with a solid foundation for trendsetting systems which feature a reliable operation you can surely benefit from. The product management at MONACOR: market-oriented, innovative and inspirational.



# Knowledge is the Key to success!

As of spring 2021

MONACOR ACADEMY is our new knowledge portal which offers an advanced and contemporary possibility to digitally and efficiently provide you with knowledge: fast, flexible and cost-efficient.

#### At the MONACOR ACADEMY we offer you:

- Attractive online training courses with different tutors from the audio sector
- Informative how-to videos on our solutions
- Activating product presentations of highlights and innovations
- Nice-to-know fact sheets on various audio topics
- Product information for downloading

#### Exclusively to our customers!

Offering successful training and advanced training does not only mean to provide you with knowledge; it will also give you the necessary skills and abilities. Use this chance to obtain more knowledge and register at our MONACOR ACADEMY at [www.monacor.de/academy](http://www.monacor.de/academy) to benefit from significant advantages which also include the following:

- Maximum time flexibility = no matter when: 24/7
- Local independence = no matter where
- Any repetition of the teaching/information material = no matter how often

## MONACOR ACADEMY

24 hours, 7 days a week

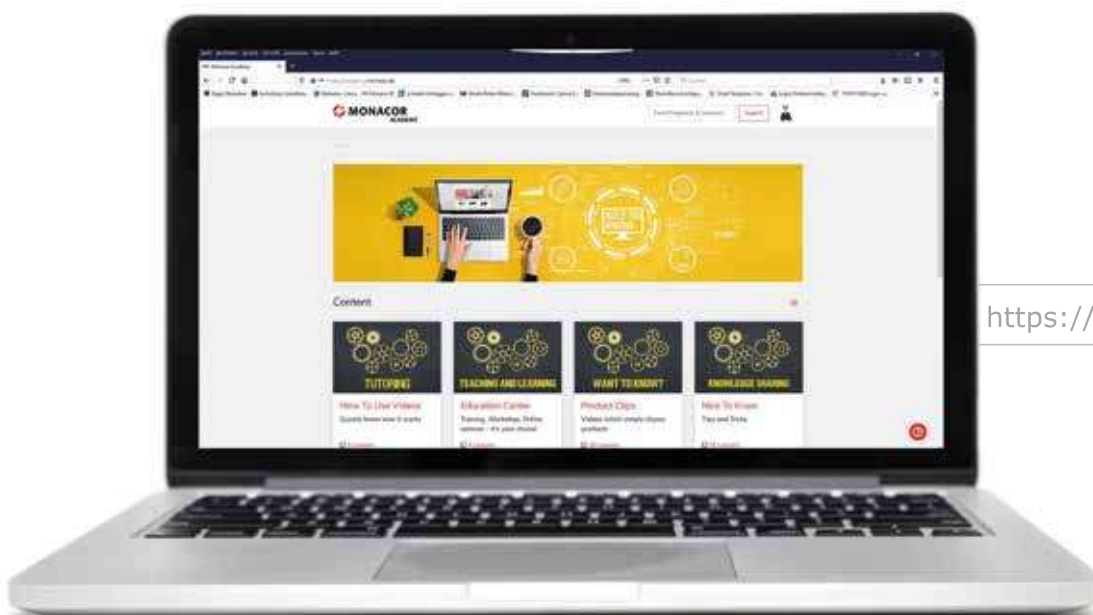

<https://monacor.de/academy>

**Mobile PA** ..... R4  
 Systems

**Megaphones** ..... R13

**Tour Guide Systems** ..... R17

**Highlights** ..... R32  
 DELTA-160, FLAT-M Series, FLY-16, Recording Bundles

**Microphones** ..... R36  
 Large Diaphragm Microphones, Vocal Microphones, Instrument Microphones,  
 Wireless Transmission, Accessories

**Mixers** ..... R64  
 Digital Mixers, Analogue Mixers, Recording Interfaces

**Audio Tools** ..... R80  
 DI Boxes, Line Combiners/Splitters, Preamplifiers, Headphone Amplifiers, Headphones,  
 Signal Processing, Audio Players

**PA Systems** ..... R90  
 Analogue Amplifiers, Class D Amplifiers, Powered Mixers, PA Systems, PA Speaker Systems,  
 PA Monitor Speaker Systems, PA Subwoofers

**Components** ..... R110  
 Stage and Audio Accessories, Cables and Plug-in Connectors

**JTS products can be found from page R129 onwards.**



# Portable PA Systems Systems

## TXA-1020

Order No. 0174590

## TXA-1020USB

Order No. 0174600

## TXA-1022CD

Order No. 0174610



**Portable high-power amplifier systems**, with integrated adjustable 2-channel multifrequency receiver unit with UHF PLL technology and Bluetooth receiver.

- High-performance class D version 120 W, with optimum efficiency
- Operation via mains connection or built-in rechargeable lead gel battery 2 x 12 V/4.5 Ah (operating time: up to 4 hours), integrated automatic battery charging with charging status indication, discharge protection
- For mobile applications, e.g. sales events, lectures
- 2 x 16 selectable UHF frequencies (863.1-864.9 MHz)
- Efficient 2-way speaker system with 25 cm (10") bass speaker
- 1 microphone input via comb. jack (XLR/6.3 mm), 1 microphone input (6.3 mm jack), 1 stereo line input (RCA), 1 aux input (3.5 mm jack), each input can be adjusted
- Common master control, 2-way tone control
- 1 stereo line output (RCA), 1 aux output (3.5 mm jack)
- Switchable microphone priority circuit
- Due to an extractable telescopic handle and 2 castors, the amplifier system can easily be pulled like a trolley
- Stand sleeve

### TXA-1020:

– Amplifier system with 2-channel wireless receiver

### TXA-1020USB:

- Amplifier system with 2-channel wireless receiver
- MP3 player with SD card reader and USB interface
- Supplied with remote control for MP3 player

### TXA-1022CD:

- Amplifier system with 2-channel wireless receiver
- CD player with anti-shock system, MP3 reproduction and slot-in mechanism, pitch control function
- SD card reader, USB interface
- 1 wireless transmitter for wireless audio link operation of several TXA-1020 systems
- Supplied with remote control for CD player

Matching microphone transmitters or pocket transmitters, e.g. TXA-800HSE, TXA-800HT or multifrequency transmitter module TXA-1020MT are available at option.



### Licence-free in the EU.

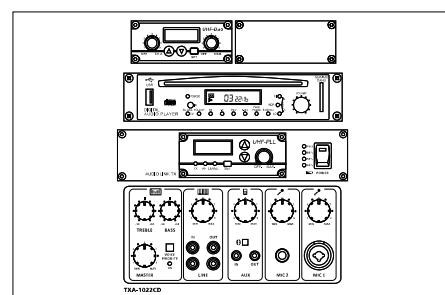
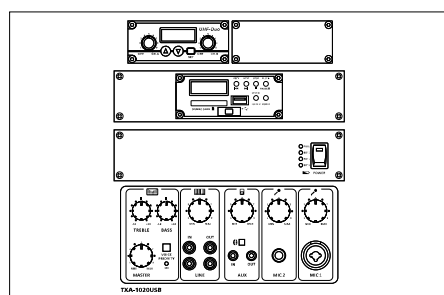
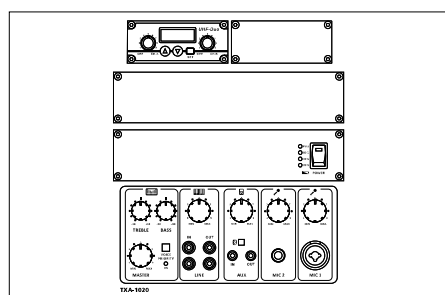

Model	TXA-1020	TXA-1020USB	TXA-1022CD
Rated power (P <sub>RMS</sub> )	120 W	120 W	120 W
Peak output power	170 W	170 W	170 W
Frequency range	20-20,000 Hz	20-20,000 Hz	20-20,000 Hz
Carrier frequency	863.1-864.9 MHz	863.1-864.9 MHz	863.1-864.9 MHz
Operating range	≈ 30 m	≈ 30 m	≈ 30 m
Inputs	6 mV (mic), 300 mV (line, aux)	6 mV (mic), 300 mV (line, aux)	6 mV (mic), 300 mV (line, aux)
Link	optional (TXA-1020MT)	optional (TXA-1020MT)	wireless
Equalizer, bass	±10 dB/100 Hz	±10 dB/100 Hz	±10 dB/100 Hz
Equalizer, treble	±10 dB/10 kHz	±10 dB/10 kHz	±10 dB/10 kHz
Power supply	~ 230 V/50 Hz/170 VA, rech. battery: 2 x 12 V/4.5 Ah	~ 230 V/50 Hz/170 VA, rech. battery: 2 x 12 V/4.5 Ah	~ 230 V/50 Hz/170 VA, rech. battery: 2 x 12 V/4.5 Ah
Admiss. ambient temp.	0-40 °C	0-40 °C	0-40 °C
Dimensions	360 x 580 x 320 mm	360 x 580 x 320 mm	360 x 580 x 320 mm
Weight	17.8 kg	17.25 kg	18.2 kg
Connections	1 x XLR/6.3 mm jack (mic), 1 x 6.3 mm jack (mic), 1 x RCA L/R (line in), 1 x 3.5 mm jack (line in), 1 x RCA L/R (line out), 1 x 3.5 mm jack (line out)	1 x XLR/6.3 mm jack (mic), 1 x 6.3 mm jack (mic), 1 x RCA L/R (line in), 1 x 3.5 mm jack (line in), 1 x RCA L/R (line out), 1 x 3.5 mm jack (line out)	1 x XLR/6.3 mm jack (mic), 1 x 6.3 mm jack (mic), 1 x RCA L/R (line in), 1 x 3.5 mm jack (line in), 1 x RCA L/R (line out), 1 x 3.5 mm jack (line out)

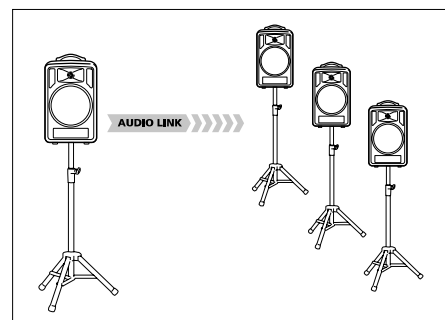

### Audio link operation:

The integrated wireless transmitter of the TXA-1022CD transmits audio signals to one or several TXA-1020 systems. Ideally suited for larger indoor PA applications where a consistent sound radiation is required.

## TXA-1020DMP

Order No. 0174620



**MP3 player insertion module**, with USB interface and SD/MMC card slot.

For retrofitting amplifier systems of the TXA-1020 series.

- USB storage media can be connected directly
- For SD/MMC cards (FAT16/FAT32), available at option
- Fast forward and reverse
- Repeat function (repeat 1, repeat all)
- Green backlit LCD
- Supplied with infrared remote control

Model	TXA-1020DMP
Media	MP3, USB, SD, MMC
Output, analogue	600 mV
Power supply	= 12 V/60 mA
Operating voltage (possible alternative)	= 12 V
Power supply (possible alternative)	= 60 mA
Admiss. ambient temp.	0-40 °C
Dimensions	191 x 43 x 99 mm
Weight	176 g
Connections	modular jack



## TXA-1802CD

Order No. 0176490



**CD player insertion module**, with anti-shock system and MP3 reproduction.

- Particularly suitable for the TXA-10xx and TXA-80x series
- Slot-in mechanism
- SD card reader
- USB port for external storage media
- Pitch control function
- Folder navigation

Model	TXA-1802CD
Media	CD, MP3, USB, SD, MMC
Output, analogue	1 V
Power supply	= 12 V/1 A
Operating voltage (possible alternative)	= 12 V
Power supply (possible alternative)	= 1 A
Admiss. ambient temp.	0-40 °C
Dimensions	190 x 43 x 190 mm
Weight	1.04 kg
Connections	modular jack



## TXA-1822MR

Order No. 0179090

**2-channel multifrequency receiver module**, with UHF PLL technology.

For retrofitting amplifier systems of the TXA-1020 and TXA-820 series or for setting up wireless audio transmission paths.

- 2 x 16 selectable UHF frequencies (863-865 MHz)
- Volume control
- LCD for indicating selected channel and carrier frequency

Model	TXA-1822MR
Carrier frequency range	863-865 MHz
Admiss. ambient temp.	0-40 °C
Power supply receiver	= 12 V/185 mA
Dimensions receiver	88 x 37 x 113 mm
Weight receiver	92 g

- Scan function for free channel
- Supplied with adapter board for TXA-1020 series

**Licence-free in the EU.**



## TXA-1020MT

Order No. 0174640

**Multifrequency transmitter module**, with UHF PLL technology.

For retrofitting amplifier systems of the TXA-1020 series or for setting up wireless audio transmission paths.

- 16 selectable UHF frequencies (863.1-864.9 MHz)
- Volume control
- LCD for indicating selected channel/frequency
- LEDs for indicating carrier and audio signals

Model	TXA-1020MT
Carrier frequency range	863.1-864.9 MHz
Admiss. ambient temp.	0-40 °C
Transmitting power	≤ 10 mW
Operating range	approx. 30 m
Power supply transmitter	= 12 V/140 mA
Dimensions transmitter	91 x 43 x 103 mm
Weight transmitter	220 g

**Licence-free in the EU.**



## TXA-800ST

Order No. 0172600

**16-channel PLL transmitter**, for microphone operation and line audio signals.

- Matching the receivers TXA-800R, ATS-16R and portable amplifiers of the TXA-800 series, TXA-1020 series
- 16 selectable UHF frequencies (863.1-864.9 MHz)
- Adjustable headphone output
- 482 mm (19") rack installation of 2 devices is possible with supplied mounting brackets

Model	TXA-800ST
Carrier frequency range	863.1-864.9 MHz
Admiss. ambient temp.	0-40 °C
Transmitting power	10 mW
Operating range	approx. 30 m
Power supply transmitter	via encl. plug-in power supply
Dimensions transmitter	215 x 50 x 210 mm
Weight transmitter	1.25 kg
Connections transmitter	1 x XLR, bal. (mic in), 1 x 6.3 mm jack, unbal. (mic in), 1 x RCA L/R (line in), 1 x RCA L/R (line out)

**Licence-free in the EU.**



# Portable PA Systems Systems

## TXA-820

Order No. 0179050

## TXA-820CD

Order No. 0179060

## TXA-822CD

Order No. 0179070



**Portable amplifier system**, with integrated multi-frequency receiver unit with UHF PLL technology (863-865 MHz) and Bluetooth receiver.

- Operation via mains connection or built-in rechargeable lead gel battery 2 x 12 V/4.5 Ah (operating time: up to 5 hours), integrated automatic battery charging with charging status indication, discharge protection
- For mobile applications, e.g. sales events, lectures
- Efficient 2-way speaker system
- 1 microphone input via comb. jack (XLR/6.3 mm), 1 microphone input (6.3 mm jack), 1 stereo line input (RCA), 1 aux input (3.5 mm jack), each input can be adjusted
- Common master control, 2-way tone control
- 1 stereo output (RCA), 1 aux output (3.5 mm jack)
- Switchable microphone priority circuit
- Due to an extractable telescopic handle and 2 castors, the amplifier system can easily be pulled like a trolley
- Stand sleeve

**Licence-free in the EU.**

### TXA-820:

- Amplifier system with 1-channel wireless receiver
- 16 selectable UHF frequencies (863-865 MHz) with diversity system

### TXA-820CD:

- Amplifier system with 1-channel wireless receiver
- 16 selectable UHF frequencies (863-865 MHz) with diversity system
- CD player with anti-shock system, MP3 reproduction and slot-in mechanism
- SD card reader, USB interface
- Pitch control function
- Supplied with remote control for CD player

### TXA-822CD:

- Amplifier system with 2-channel wireless receiver
- 2 x 16 selectable UHF frequencies (863-865 MHz)
- CD player with anti-shock system, MP3 reproduction and slot-in mechanism
- SD card reader, USB interface
- Pitch control function
- Supplied with remote control for CD player
- 1 wireless transmitter for wireless audio link operation of several TXA-820 systems



Matching microphone transmitters or pocket transmitters are available at option, e.g. TXA-800HSE, TXA-800HT or ATS-12HT.

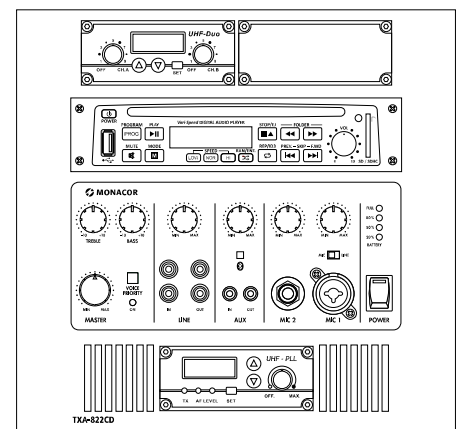
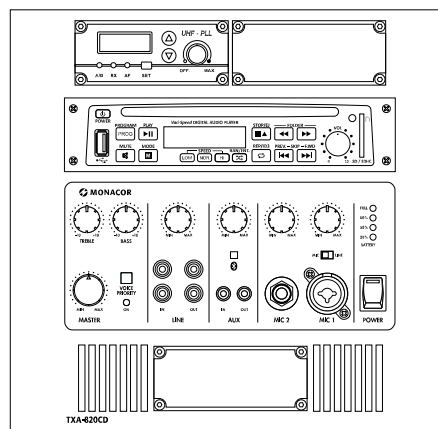
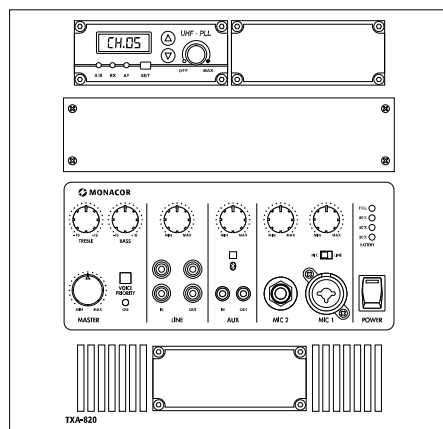

Model	TXA-820	TXA-820CD	TXA-822CD
Rated power (P <sub>RMS</sub> )	50 W	50 W	50 W
Peak output power	80 W	80 W	80 W
Frequency range	70-17,000 Hz	70-17,000 Hz	70-17,000 Hz
Carrier frequency	863-865 MHz	863-865 MHz	863-865 MHz
Operating range	≈ 30 m	≈ 30 m	≈ 30 m
Inputs	6 mV (mic), 300 mV (line)	6 mV (mic), 300 mV (line)	6 mV (mic), 300 mV (line)
Link	optional (TXA-820MT)	optional (TXA-820MT)	wireless
Max. SPL	114 dB	114 dB	114 dB
Equalizer, bass	±10 dB/100 Hz	±10 dB/100 Hz	±10 dB/100 Hz
Equalizer, treble	±10 dB/10 kHz	±10 dB/10 kHz	±10 dB/10 kHz
Power supply	~ 230 V/50 Hz/130 VA, rech. battery 2 x 12 V/4.5 Ah	~ 230 V/50 Hz/130 VA, rech. battery 2 x 12 V/4.5 Ah	~ 230 V/50 Hz/130 VA, rech. battery 2 x 12 V/4.5 Ah
Admiss. ambient temp.	0-40 °C	0-40 °C	0-40 °C
Dimensions	305 x 510 x 265 mm	305 x 510 x 265 mm	305 x 510 x 265 mm
Weight	14.5 kg	15.5 kg	15.5 kg
Connections	1 x XLR/6.3 mm jack (mic/line), 1 x 6.3 mm jack (mic), 1 x RCA L/R (line out), 1 x 3.5 mm jack (line out)	1 x XLR/6.3 mm jack (mic/line), 1 x 6.3 mm jack (mic), 1 x RCA L/R (line out), 1 x 3.5 mm jack (line out)	1 x XLR/6.3 mm jack (mic/line), 1 x 6.3 mm jack (mic), 1 x RCA L/R (line out), 1 x 3.5 mm jack (line out)



## TXA-800HT

Order No. 0172260

**Hand-held microphone with integrated multi-frequency transmitter**, with UHF PLL technology. Matching portable amplifier systems of the TXA-1000 and TXA-800 series.

- Dynamic microphone cartridge, cardioid polar pattern
- 16 selectable UHF frequencies (863.1-864.9 MHz)
- Sensitivity to be adjusted in 2 steps
- Mute function
- Backlit LCD for indicating channel/frequency and battery status
- Transmitting power: 10 mW (EIRP)
- Power supply via 2 x 1.5 V battery AA size (not supplied)
- Supplied with 4 coloured caps to be pushed on

**Licence-free in the EU.**

Model	TXA-800HT
Polar pattern	cardioid
System	dynamic
Carrier frequency range	863.1-864.9 MHz
Transmitting power	10 mW
Power supply	2 x 1.5 V batt. AA size
Audio frequency range	70-16,000 Hz
Admiss. ambient temp.	0-40 °C
Dimensions	Ø 46 mm x 265 mm
Weight	250 g



## TXA-800HSE

Order No. 0172250

**Multifrequency pocket transmitter**, with UHF PLL technology. Matching portable amplifier systems of the TXA-1000 series, TXA-800 series and TXA-800R.

- 1 headband microphone (omnidir. char.), 1 tie clip microphone (cardioid char.)
- 16 selectable UHF frequencies (863.1-864.9 MHz)
- Metal housing
- Microphone connection via 3-pole mini XLR jack
- Audio line input via 3.5 mm stereo jack
- Sensitivity to be adjusted in 3 steps
- Mute function
- Backlit LCD for indicating channel/frequency and battery status

Model	TXA-800HSE
Carrier frequency range	863.1-864.9 MHz
Audio frequency range	70-16,000 Hz
Admiss. ambient temp.	0-40 °C
Transmitting power	10 mW
Operating range	30 m
Power supply transmitter	2 x 1.5 V batt. AA size
Dimensions transmitter	65 x 95 x 30 mm
Weight transmitter	110 g
Connections transmitter	1 x 3-pole mini XLR

- Transmitting power: 10 mW (EIRP)
- Power supply via 2 x 1.5 V battery AA size (not supplied)
- Belt clip

**Licence-free in the EU.**



## TXA-820MT

Order No. 0179080

**Multifrequency transmitter module**, with UHF PLL technology.

For retrofitting amplifier systems of the TXA-820 series or for setting up wireless audio transmission paths.

- 16 selectable UHF frequencies (863-865 MHz)
- Volume control
- LCD for indicating selected channel/frequency
- LEDs for indicating carrier signal and audio signal

**Licence-free in the EU.**

Model	TXA-820MT
Carrier frequency range	863-865 MHz
Admiss. ambient temp.	0-40 °C
Transmitting power	≤ 10 mW
Operating range	approx. 30 m
Power supply transmitter	≈ 12 V/120 mA
Dimensions transmitter	88 x 37 x 113 mm



# Portable PA Systems Systems

## Professional 16-channel Mono PLL Audio Transmission System, 863-865 MHz

- Compatible with portable amplifier systems of the TXA-820 and TXA-1020 series
- Can be combined with the TXA-820 and TXA-1020 series, but also suitable as a tour guide system and for any other application in which a certain audio source or voice source is to be distributed to one or more receivers
- Licence-free in the EU.

### TXA-802SR

Order No. 0172990

**2-channel multifrequency receiver,**  
with UHF PLL technology.

- Matching the transmitters TXA-800HT, TXA-800HSE, TXA-800ST and ATS-12HT
- 2 x 16 selectable UHF frequencies (863.1-864.9 MHz) with diversity system
- Scan function for free channel
- Volume control
- LCD for indicating selected channel and carrier signal
- Balanced XLR output and 6.3 mm jack output
- 482 mm (19") rack installation of 2 devices is possible with supplied mounting brackets



- Power is provided via enclosed plug-in power supply
- Dimensions: 215 x 50 x 210 mm
- Weight: 1.2 kg

**Licence-free in the EU.**

### TXA-800R

Order No. 0172590

**16-channel PLL receiver**

- Matching the transmitters TXA-800ST, TXA-800HT, TXA-800HSE, ATS-16T and portable amplifier system TXA-802CD with integrated wireless transmitter
- 16 selectable UHF frequencies (863.1-864.9 MHz)
- Adjustable headphone output
- Line output level adjustable in 3 steps
- Metal housing
- Power supply via 2 x 1.5 V battery AA size or NiMH rech. battery (not supplied)
- Scope of delivery includes earphones with rubber ear hook
- Belt clip



**Licence-free in the EU.**

### TXA-802PS

Order No. 0255860

**PWM quick-charge station,**  
for simultaneously charging the rechargeable batteries (NC, NiMH) of one multifrequency pocket transmitter TXA-800HSE or the receiver TXA-800R and one hand-held microphone with multifrequency transmitter TXA-800HT.

- Average charging time, depending on capacity and condition of the rechargeable batteries used: approx. 4-5 hours, e.g. for 1,600 mAh



- rech. batteries
- Each slot with LED for indicating battery charging status
- Supplied with plug-in PSU

### TXA-800PS

Order No. 0252140

**Intelligent PWM quick-charge station,**  
for simultaneously charging rech. batteries (NC, NiMH) of two receivers TXA-800R, also suitable for transmitter TXA-800HSE.

- Average charging time, depending on capacity and condition of the rechargeable batteries used: approx. 3-4 hours, e.g. for 1,300 mAh rech. batteries



- Each slot with LED for indicating a fault and battery charging status
- Mechanical reverse polarity protection
- Including plug-in power supply

### TXA-12C

Order No. 0252150

**Transport case with intelligent PWM quick-charge function,**  
for receiver TXA-800R and transmitter TXA-800HSE.

- For simultaneously charging rech. batteries (NC, NiMH) of up to 12 units
- Average charging time, depending on capacity and condition of the rechargeable batteries used: approx. 5-6 hours, e.g. for 1,300 mAh rech. batteries
- Each slot with LED for indicating a fault and battery charging status
- Mechanical reverse polarity protection



- Wooden case with black imitation leather cover
- Supplied with matching power supply
- Dimensions: 300 x 170 x 280 mm

**Supplied w/o devices.**

### TXA-36C

Order No. 0252160

**Transport case with intelligent PWM quick-charge function,**  
for receiver TXA-800R and transmitter TXA-800HSE.

- For simultaneously charging rech. batteries (NC, NiMH) of up to 36 devices
- Average charging time, depending on capacity and condition of the rech. batteries used: approx. 5-6 hours, e.g. for 1,300 mAh rech. batteries
- Each slot with LED for indicating a fault and battery charging status
- Mechanical reverse polarity protection



- Lockable plastic transport case fitted with castors
- Including matching switch-mode power supply
- Dimensions: 860 x 230 x 350 mm

**Supplied w/o devices.**

## TXA-1000WPB

Order No. 0173630



**Protective cover, splashproof version**, suitable for portable amplifier systems of the TXA-1020, TXA-1020USB and TXA-1022CD.

- Robust, black synthetic cloth
- Sound-transparent front of meshed fabric with additional water protection cover

- The cover can stay on during operation
- Opening for transport handle and trolley handle
- 2 lateral pockets, each with hook and loop fastener

**Supplied w/o device.**



## TXA-820WPB

Order No. 0179110



**Protective cover, splashproof version**, suitable for portable amplifier systems TXA-820, TXA-820CD and TXA-822CD.

- Robust, black synthetic cloth
- Sound-transparent front of meshed fabric with additional water protection cover

- The cover can stay on during operation
- Opening for transport handle and trolley handle
- 2 lateral pockets, each with hook and loop fastener

**Supplied w/o device.**



## TXA-1000BAG

Order No. 0172820

**Protective cover**, suitable for portable amplifier systems TXA-1020, TXA-1020USB and TXA-1022CD.

- Robust, black synthetic cloth
- Sound-transparent front of meshed fabric
- The cover can stay on during operation

- Opening for transport handle and trolley handle
- 2 lateral pockets, each with hook and loop fastener

**Supplied w/o device.**



## TXA-820BAG

Order No. 0179100

**Protective cover**, suitable for portable amplifier systems TXA-820, TXA-820CD and TXA-822CD.

- Robust, black synthetic cloth
- Sound-transparent front of meshed fabric
- The cover can stay on during operation

- Opening for transport handle
- 2 lateral pockets, each with hook and loop fastener

**Supplied w/o device.**



## TXA-1015ACCU

Order No. 0173210

**Rechargeable lead battery, 12 V**, universal rech. battery, also suitable as a replacement for the TXA-10xx series, TXA-82xx series and TXA-700USB.

- 12 V/4,5 Ah

- Maintenance-free, hermetically sealed
- Dimensions: 90 x 110 x 70 mm
- Weight: 1.8 kg



## TXA-815ACCU

Order No. 0172930

**Rechargeable lead battery, 12 V**, universal rech. battery, also suitable as a replacement for TXA-110 and the TXA-800 series.

- 12 V/2,9 Ah

- Maintenance-free, hermetically sealed
- Dimensions: 79 x 107 x 56 mm
- Weight: 1.2 kg





# Portable PA Systems Systems

## TXA-700USB

Order No. 0174750



**Portable amplifier system**, with wireless microphone, integrated Bluetooth receiver and USB/SD card player.

- High-performance class D version 80 W, with optimum efficiency
- Operation via mains connection or built-in lead gel battery 2 x 12 V/5 Ah (operating time: up to 6 hours), integrated automatic battery charging
- For mobile applications, e.g. sales events, lectures
- Wireless microphone with adjustable wireless UHF receiver
- Bluetooth receiver for wireless connection of portable audio players
- Adjustable USB/SD card player with connection for external storage media
- Remote control
- 2-way speaker system
- 2 adjustable inputs via comb. jacks (XLR/6.3 mm jack), switchable mic/line
- 1 aux input (3.5 mm jack, RCA)
- Adjustable reverb
- Common master control with 2-way tone control
- 1 line output (6.3 mm jack)

Model	TXA-700USB
Rated power (P <sub>RMS</sub> )	80 W
Peak output power	120 W
Frequency range	55-20,000 Hz
Carrier frequency	863-865 MHz
Inputs	10 mV (mic), 950 mV (line), 1.4 V (aux)
Equalizer, bass	± 12 dB/55 Hz
Equalizer, treble	± 12 dB/15 kHz
Power supply	~ 230 V/50 Hz/40 VA, rech. battery: 2 x 12 V/5 Ah
Admiss. ambient temp.	0-40 °C
Dimensions	360 x 560 x 325 mm
Weight	17 kg
Connections	2 x XLR/6.3 mm jack (mic/line), 1 x RCA L/R (aux), 1 x 3.5 mm jack (aux), 1 x 6.3 mm jack (line out)

- Due to integrated extractable telescopic handle and 2 castors, amplifier system can easily be pulled like a trolley
- Stand sleeve

**Licence-free in the EU.**



## TXA-15USB

Order No. 0173150



**Portable amplifier system**, with integrated Bluetooth receiver and USB/SD card player.

- Operation via mains connection or built-in lead gel battery 12 V/7.2 Ah (operating time: up to 6 hours), integrated automatic battery charging
- For mobile applications, e.g. sales events, lectures
- Bluetooth receiver for wireless connection of portable audio players
- Adjustable USB/SD card player with connection for external storage media
- 2-way speaker system
- 1 adjustable balanced microphone input via XLR, 1 adjustable microphone input via 6.3 mm mono jack, 1 adjustable CD/Tape input via RCA
- Adjustable master output with 3-way equalizer
- Link connection (6.3 mm jack) for combining several TXA-15USB systems
- Cabinet in flight case design, with drop handles
- Due to integrated extractable telescopic handle and 2 castors, amplifier system can easily be pulled like a trolley
- Stand sleeve

Model	TXA-15USB
Rated power (P <sub>RMS</sub> )	15 W
Peak output power	20 W
Frequency range	70-20,000 Hz
Inputs	6 mV (mic), 600 mV (line)
Link	380 mV
Equalizer, bass	± 15 dB/100 Hz
Equalizer, midrange	± 15 dB/2.5 kHz
Equalizer, treble	± 15 dB/10 kHz
Power supply	~ 230 V/50 Hz/60 VA, rech. battery: 12 V/7.2 Ah
Admiss. ambient temp.	0-40 °C
Dimensions	410 x 470 x 310 mm
Weight	16.4 kg
Connections	1 x XLR (mic), 1 x 6.3 mm jack (mic), 1 x RCA L/R (line), 1 x 6.3 mm jack (link)



## PAS-254D

Order No. 0179240



**Portable amplifier system**, for processions and other mobile applications.

- Very comfortable to wear and great mobility due to backpack method
- 1 speaker with 4 speaker chassis
- Class D power amplifier
- Integrated 2-channel multifrequency wireless receiver (TXA-1822MR)
- Bluetooth receiver for wireless connection of mobile audio devices
- Adjustable USB/SD card player with connection for external storage media
- Built-in rechargeable lead gel battery 12 V/7.2 Ah (operating time: up to 7 hours)
- Compartment for spare rechargeable battery to extend operating time
- Integrated automatic battery charging
- Charging socket for supplied charger
- 1 input via comb. jack mic (XLR)/line (6.3 mm), gain control, tone control, mic input with 12 V phantom power
- 1 stereo line input via RCA jacks, gain control, tone control
- MIX OUT output (RCA)

Model	PAS-254D
Rated power (P <sub>RMS</sub> )	70 W
Peak output power	80 W
Frequency range	80-20,000 Hz
Carrier frequency	863.1-864.9 MHz
Operating range	≈ 100 m
Inputs	2 mV (mic), 14 mV (line, jack), 80 mV (line, RCA)
Link	300 mV
Power supply	rech. batt. 12 V/7.2 Ah
Admiss. ambient temp.	0-40 °C
Dimensions	Total length: 120 cm
Weight	7.7 kg
Connections	1 x XLR (mic), 1 x 6.3 mm jack (line), 1 x RCA L/R (line in), 1 x RCA L/R (line out), 1 x USB, 1 x SPEAKER

- Output for a speaker (min. impedance: 4 Ω), either additionally or alternatively to existing speakers
- Adjustable voice over function
- Limiter function
- Nylon backpack with storage pockets

Matching microphone transmitters or pocket transmitters are available at option, e.g. TXA-800HT and TXA-800HSE.

**Licence-free in the EU.**



## TXA-110

Order No. 0172420

**Portable amplifier system**, with integrated adjustable multifrequency receiver unit with UHF PLL technology.

- Operation via built-in rechargeable lead gel battery 12 V/2.7 Ah (operating time: up to 3 hours) or enclosed switch-mode power supply
- Integrated automatic battery charging

**Licence-free in the EU.**

Model	TXA-110
Rated power (P <sub>RMS</sub> )	36 W
Peak output power	50 W
Frequency range	60-15,000 Hz
Carrier frequency	863.050-864.925 MHz
Operating range	≈ 30 m
Inputs	10 mV (mic), 100 mV (line)
Equalizer, treble	± 8 dB/10 kHz
Power supply	rech. batt. 12 V/2.7 Ah, via encl. power supply
Admiss. ambient temp.	0-40 °C
Dimensions	160 x 210 x 290 mm
Weight	3.15 kg
Connections	1 x 6.3 mm jack (mic), 1 x 3.5 mm jack (line in), 1 x 3.5 mm jack (mix out)



## TXA-100HT

Order No. 0172450

**Hand-held microphone with integrated multifrequency transmitter**, with UHF PLL technology. Matching the portable amplifier system TXA-110.

- Dynamic microphone cartridge, cardioid polar pattern
- 16 selectable UHF frequencies (863.05-864.925 MHz)

**Licence-free in the EU.**

Model	TXA-100HT
Polar pattern	cardioid
System	dynamic
Carrier frequency range	863.05-864.925 MHz
Transmitting power	< 10 mW
Power supply	2 x 1.5 batt. AA size
Audio frequency range	50-18,000 Hz
Admiss. ambient temp.	0-40 °C
Dimensions	Ø 50 mm x 255 mm
Weight	257 g



## TXA-100HSE

Order No. 0172440

**Multifrequency pocket transmitter**, with UHF PLL technology. Matching the portable amplifier system TXA-110.

- 1 headband microphone (omnidir. polar pattern), 1 tie clip microphone (cardioid polar pattern)
- 16 selectable UHF frequencies (863.050-864.925 MHz)

Model	TXA-100HSE
Carrier frequency range	863.050-864.925 MHz
Audio frequency range	50-18,000 Hz
Admiss. ambient temp.	0-40 °C
Transmitting power	< 10 mW
Power supply transmitter	2 x 1.5 V batt. AA size
Dimensions transmitter	65 x 100 x 35 mm
Weight transmitter	163 g
Connections transmitter	1 x 3-pole mini XLR

**Licence-free in the EU.**



# Portable PA Systems Systems

## TXA-624CD/SW

Order No. 0179150



**Portable amplifier system**, with integrated 2-channel multifrequency receiver unit in UHF PLL technology and CD player with anti-shock system.

- Operation via mains connection or built-in rechargeable lead gel battery 12 V/7.2 Ah (operating time: up to 10 hours), integrated automatic battery charging
- For mobile applications, e.g. sales events, lectures
- 2 x 16 selectable UHF frequencies (863.1-864.9 MHz)
- High-quality CD player with slot-in mechanism, USB port for external storage media, reproduction of audio CD, CD-R, MP3 CD
- 2-way bass-reflex speaker system
- Excellent sound characteristics due to 20 cm (8", Fatial) bass speaker and 25 mm (1") tweeter
- 1 input via comb. jack mic (XLR)/line (6.3 mm), gain control, 3-way equalizer
- Supplied with practical protective bag which can stay on during operation

Model	TXA-624CD/SW
Rated power (P <sub>RMS</sub> )	50 W
Peak output power	75 W
Frequency range	50-18,500 Hz
Carrier frequency	863.1-864.9 MHz
Operating range	≈ 30 m
Inputs	4.5 mV, XLR (mic), 30 mV, 6.3 mm jack (line), 200 mV, RCA (line)
Equalizer, bass	±12 dB/55 Hz
Equalizer, midrange	±6 dB/1 kHz
Equalizer, treble	±8 dB/10 kHz
Power supply	~ 230 V/50 Hz/60 VA, rech. batt. 12 V/7.2 Ah
Admiss. ambient temp.	0-40 °C
Dimensions	235 x 450 x 280 mm
Weight	9.7 kg
Connections	1 x XLR (mic), 1 x 6.3 mm jack (line), 1 x RCA L/R (line), 1 x RCA L/R (mix out, link), 1 x SPEAKON (ext. speakers)

Matching microphone transmitters or pocket transmitters are available at option, e.g. TXA-800HSE or TXA-800HT.

**Licence-free in the EU.**



## TXA-604/SW

Order No. 0179140

**Portable amplifier system**, with integrated 2-channel multifrequency receiver unit in UHF PLL technology.

- Operation via mains connection or built-in rechargeable lead gel battery 12 V/7.2 Ah (operating time: up to 10 hours), integrated automatic battery charging
- For mobile applications, e.g. sales events, lectures
- 2 x 16 selectable UHF frequencies (863.1-864.9 MHz)
- Class D power amplifier
- Cabinet with durable two-component PU coating
- 2-way bass-reflex speaker system
- Excellent sound characteristics due to a 20 cm (8", FAITAL) bass speaker and 25 mm (1") horn tweeter
- 1 input via comb. jacks mic (XLR)/line (6.3 mm), gain control, 3-way tone control
- 1 stereo line input via RCA jacks, gain control, common 2-way tone control
- Adjustable talkover
- Link connections (RCA) for combining several amplifier systems TXA-624CD/SW or TXA-604/SW

Model	TXA-604/SW
Rated power (P <sub>RMS</sub> )	50 W
Peak output power	75 W
Frequency range	50-18,500 Hz
Carrier frequency	863.1-864.9 MHz
Operating range	≈ 30 m
Inputs	4.5 mV, XLR (mic), 30 mV, 6.3 mm jack (line), 200 mV, RCA (line)
Equalizer, bass	±12 dB/55 Hz
Equalizer, midrange	±6 dB/1 kHz
Equalizer, treble	±8 dB/10 kHz
Power supply	~ 230 V/50 Hz/60 VA, rech. batt. 12 V/7.2 Ah
Admiss. ambient temp.	0-40 °C
Dimensions	235 x 450 x 280 mm
Weight	9.7 kg
Connections	1 x XLR (mic), 1 x 6.3 mm jack (line), 1 x RCA L/R (line), 1 x RCA L/R (mix out, link), 1 x SPEAKON (ext. speaker)

- SPEAKON connection (4 Ω) for external speaker TXB-602/SW
- Supplied with practical protective shoulder bag which can stay on during operation

Matching microphone transmitters or pocket transmitters are available at option, e.g. TXA-800HSE or TXA-800HT.

**Licence-free in the EU.**

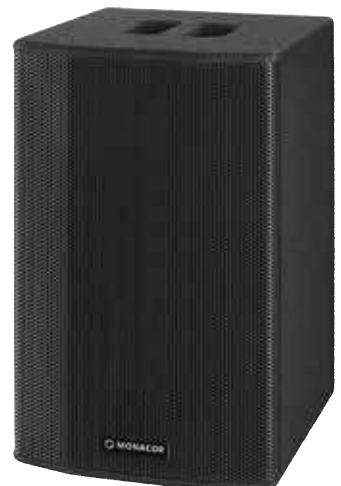

## TXB-602/SW

Order No. 0130050

**Speaker system, 50 W, 4 Ω**, suitable for portable amplifier systems TXA-604/SW and TXA-624CD/SW.

- Cabinet with durable two-component PU coating
- 2-way bass-reflex speaker system
- Excellent sound characteristics due to a 20 cm (8", FAITAL) bass speaker and 25 mm (1") horn tweeter
- Frequency range: 60-18,500 Hz
- SPEAKON connection

- Stand sleeve
- Supplied with practical protective shoulder bag which can stay on during operation
- Dimensions: 240 x 400 x 290 mm
- Weight: 8.2 kg





## Attention guaranteed!

With our range of reliable megaphones, we provide the perfect solution for each application. A few basic selection criteria will help you to choose the right unit. The operating range surely is the most important one. Here, the following applies: with increasing sound pressure (in dB), the operating range of the megaphone increases, too. Furthermore, it is possible to choose between megaphones with integrated microphone, with hand-held microphone or units with an additional wireless microphone. Each megaphone from MONACOR is supplied with power by standard batteries. As an alternative, a few units also feature a 12 V connection. Size, weight and power supply are further selection criteria for choosing the right megaphone. With these

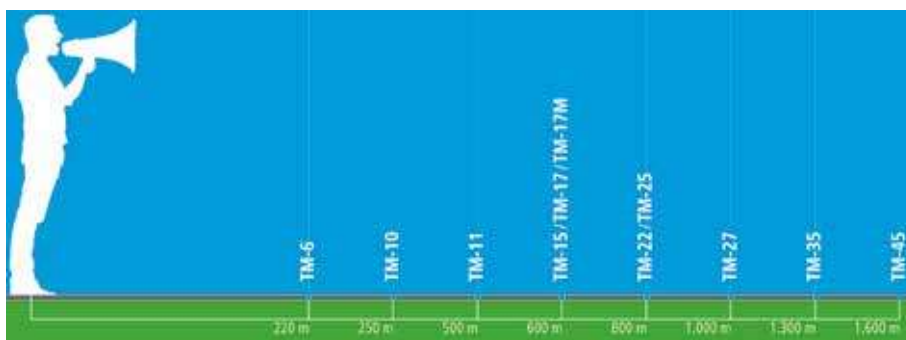

comparison criteria, you will surely find the ideal megaphone meeting your individual requirements very quickly.

A maximum sound pressure level of 60 dB will be reached at the distance stated. This usually corresponds to a conversation held at low volume.

### TM-45

Order No. 0171000

45W 124 dB

#### Megaphone

- Hand-held microphone with removable helix cable
- Lockable talk button and volume control at the microphone
- Aux input with level control
- Jack for external 12 V battery operation
- Siren, switchable
- Connection cable for motor vehicles
- 8 mm threaded bushing for mounting onto a stand

Model	TM-45
Output power ( $P_{MAX}$ )	45 W
Sensitivity	124 dB
Power supply	10 x 1.5 V batt. D size not supplied, ext. = 12 V/4 A
Dimensions	Ø 350 mm x 505 mm
Weight	3.3 kg



### TM-35

Order No. 0170990

35W 122 dB

#### Megaphone

- Hand-held microphone with helix cable
- Lockable talk button and volume control at the microphone
- Jack for external 12 V battery operation
- Siren, switchable
- Connection cable for motor vehicles
- 8 mm threaded bushing for mounting onto a stand

Model	TM-35
Output power ( $P_{MAX}$ )	35 W
Sensitivity	122 dB
Power supply	8 x 1.5 V batt. C size not supplied, ext. = 12 V/3 A
Dimensions	Ø 300 mm x 460 mm
Weight	2.5 kg



### TM-27

Order No. 0170980

25W 119 dB

#### Megaphone

- Hand-held microphone with fixed helix cable
- Lockable talk button and volume control at the microphone
- Siren, switchable
- Jack for external 12 V battery operation
- Connection cable for motor vehicles

Model	TM-27
Output power ( $P_{MAX}$ )	25 W
Sensitivity	119 dB
Power supply	8 x 1.5 V batt. C size not supplied, ext. = 12 V/2 A
Dimensions	Ø 230 mm x 340 mm
Weight	1.7 kg



# Megaphones

## TM-25

Order No. 0170970



### Megaphone

- Built-in microphone
- Siren, switchable
- Jack for external 12 V battery operation
- Volume control
- Connection cable for motor vehicles



Model	TM-25
Output power ( $P_{MAX}$ )	25 W
Sensitivity	115 dB
Power supply	8 x 1.5 V batt. C size not supplied, ext. = 12 V/2 A
Dimensions	Ø 230 mm x 370 mm
Weight	1.7 kg

## TM-22

Order No. 0172140



### Megaphone, with piezo converter.

- Low weight and low power consumption due to piezo technology
- Built-in microphone
- Siren and acoustic signal, switchable
- Volume control
- Battery status indication



Model	TM-22
Output power ( $P_{MAX}$ )	20 W
Sensitivity	115 dB
Power supply	8 x 1.5 V batt. AA size not supplied
Dimensions	Ø 195 mm x 315 mm
Weight	850 g

## TM-17M

Order No. 0176720



### Megaphone, with MP3 playback function.

- Hand-held microphone with helix cable
- Lockable talk button, volume control and buttons for recording/playback at the microphone
- Recording function via microphone (up to 20 seconds)
- MP3 module with playback function from USB flash drive or from a micro SD card
- Separate volume control for MP3 and microphone
- Operating switch for siren
- Jack for external 12 V battery operation
- Connection cable for motor vehicles

Model	TM-17M
Volume control	yes
Output power ( $P_{MAX}$ )	25 W
Sensitivity	110 dB
Power supply	8 x 1.5 V batt. size C no supplied, ext. 12 V/2 A
Dimensions	Ø 230 mm x 340 mm
Weight	1.3 kg
Other features	MP3, USB, micro SD



## TM-17

Order No. 0173500



### Megaphone

- Hand-held microphone with helix cable
- Lockable talk button and volume control at the microphone
- Operating switch for siren, speech and whistling sound
- Jack for external 12 V battery operation
- Connection cable for motor vehicles

Model	TM-17
Output power ( $P_{MAX}$ )	25 W
Sensitivity	110 dB
Power supply	8 x 1.5 V batt. C size not supplied, ext. = 12 V/2 A
Dimensions	Ø 230 mm x 340 mm
Weight	1.5 kg



### TM-15

Order No. 0173490

25W 110 dB

#### Megaphone

- Built-in microphone
- Volume control
- Operating switch for siren, speech and whistling sound

Model	TM-15
Output power (P <sub>MAX</sub> )	25 W
Sensitivity	110 dB
Power supply	8 x 1.5 V batt. C size not supplied
Dimensions	Ø 230 mm x 370 mm
Weight	1.3 kg



### TM-11

Order No. 0173480

15W 100 dB

#### Megaphone

- Built-in microphone
- Siren, switchable
- Volume control

Model	TM-11
Output power (P <sub>MAX</sub> )	15 W
Sensitivity	100 dB
Power supply	8 x 1.5 V battery AA size not supplied
Dimensions	Ø 205 mm x 340 mm
Weight	1.1 kg



### TM-10

Order No. 0173470

10W 90 dB

#### Megaphone

- Built-in microphone
- Siren, switchable
- Volume control

Model	TM-10
Output power (P <sub>MAX</sub> )	10 W
Sensitivity	90 dB
Power supply	8 x 1.5 V batt. AA size not supplied
Dimensions	Ø 158 mm x 244 mm
Weight	577 g



### TM-6

Order No. 0171800

8W 94 dB

**Megaphone**, in a plastic housing, small design.

- Built-in microphone
- Siren, switchable
- Volume control

Model	TM-6
Output power (P <sub>MAX</sub> )	8 W
Sensitivity	94 dB
Power supply	6 x 1.5 V batt. AA size not supplied
Dimensions	Ø 150 mm x 237 mm
Weight	620 g



# Megaphones

## TM-12DC

Order No. 0171030

### Connection cable

- For megaphones with external power supply
- Fitted with low-voltage plug 5.5/2.1 mm and cigarette lighter plug with power LED
- Integrated fine-wire fuse 5 A
- Also suitable for general use
- Length: 6 m



## WAP-8

Order No. 1000075



### Portable voice amplifier

Scope of delivery: 1 electret headband microphone, 1 mini electret microphone, 1 voice amplifier, 2 microphone windshields, 1 line connection cable, 1 plug-in charger and 1 carrying strap, 1 transport bag.

- For general mobile speech applications, e.g. lectures and training sessions, sales events
- Suitable for general applications due to versatile wearing options
- 20 W amplifier with volume control
- Additional line input (3.5 mm jack) for external audio sources, e.g. MP3 players and laptops
- Built-in rech. lithium polymer battery (≈7.4 V/2000 mAh), with LED status indication, charging of the rechargeable batteries via supplied plug-in charger
- Very long operating time of up to 20 hours with fully charged battery



Model	WAP-8
Rated power (P <sub>RMS</sub> )	15 W
Peak output power	20 W
Frequency range	100-10,000 Hz
THD	0.3%
Max. SPL	82 dB
Power supply	7.4 V rech. lithium polymer battery
Admiss. ambient temp.	0-40 °C
Dimensions	90 x 130 x 30 mm
Weight	288 g
Connections	1 x 3.5 mm jack (mic), 1 x 3.5 mm jack (line)

## WAP-5

Order No. 0173200



### Waistband amplifier with line input

- Supplied with a high-sensitivity electret headband microphone
- For general mobile speech applications, e.g. lectures and training sessions, sporting events, sales events
- With adjustable waist strap
- 7 W amplifier with volume control
- Additional line input (3.5 mm jack) for external audio sources, e.g. MP3 player
- Battery operation/rech. battery operation, charging of the optional rechargeable batteries via supplied plug-in charger, removal of batteries not required
- Operating time with fully charged batteries: approx. 6-8 hours
- Power supply: ≈ 9 V (6 x battery AA size)
- Supplied w/o batteries/rech. batteries



Model	WAP-5
Rated power (P <sub>RMS</sub> )	7 W (mains operation), 6 W (battery)
Peak output power	10 W (mains operation), 8 W (battery)
Power supply	via encl. power supply or 6 x batt. AA size
Admiss. ambient temp.	0-40 °C
Dimensions	190 x 90 x 55 mm
Weight	290 g
Connections	1 x 3.5 mm jack (mic), 1 x 3.5 mm jack (line)

**Do not connect the plug-in charger to the voice amplifier when using standard batteries!**

## List of Tour Guide Systems, 823-832 MHz + 863-865 MHz

Model	ATS-80	TG-98	ATS-50	ATS-42	ATS-60
<b>System</b>					
Carrier frequency range	823-832 MHz, 863-865 MHz	506-542 MHz	863-865 MHz	863-865 MHz	823-832 MHz, 863-865 MHz
Audio frequency range	300-4,500 Hz	40-18,000 Hz	150-4,000 Hz	400-5,000 Hz	100-12,000 Hz
Transmission method	digital	analogue	analogue	analogue	analogue
No. of channels	42	124	40	40	24
LCD	OLED	illuminated	x	illuminated	illuminated
Display for indicating channel/frequency	x/-	x/-	x/-	x/-	x/x
Display for indicating battery status	x	x	x	x	x
Auto. power off transmitter/receiver	-/x	-/x	-/x	-/x	-/-
Belt clip	x	x	x	-	x
Lanyard	x	x	x (optional)	x	x
Integrated rech. battery	-	-	-	-	Li-ion, 3.7 V/2,400 mAh
1.2 V NiMH rech. batt. AA size	x	x	x	x	-
Battery operation (max., transmitter/receiver) [h]	30 h	10 h	*	*	16.5/12.5
Connection for external power supply (transmitter/receiver)	-/-	-/-	-/-	-/-	5 V, micro USB
Special features	intercom function	limiter can be switched off (receiver)	-	-	supplied with USB charging cable
<b>Transmitter</b>					
	ATS-80T	TG-98TA/5	ATS-50T	ATS-42T	ATS-60T
Built-in microphone/mute function	x/x	x/x	x/x	-/-	-/-
Input for external microphone	x	x	x	x	x
Volume control	x	x	-	x	x
Channel Sync function	x	-	-	-	-
Line input	x	x	x	-	-
Channel autolock function (transmitter)	x	x	x	x	x
Transmitting power	20 mW/10 mW	50 mW/10 mW	10 mW	10 mW	50 mW/10 mW
Operating range	100 m	200 m	110 m	210 m	300/240 m
Parallel operation, max. number	42	22	12	12	6/12
Dimensions transmitter	47 x 97 x 35 mm	62 x 112 x 28 mm	42 x 98 x 24 mm	66 x 102 x 26 mm	50 x 102 x 29 mm
Weight (transmitter w/o rech. batt./batt.)	54 g	72 g	45 g	55 g	112 g **
<b>Receiver</b>					
	ATS-80R	TG-98RA/5	ATS-50R	ATS-42R	ATS-60R
Dimensions receiver	47 x 109 x 35 mm	62 x 112 x 28 mm	42 x 98 x 24 mm	66 x 102 x 26 mm	50 x 102 x 29 mm
Weight (receiver w/o rech. batt./batt.)	54 g	72 g	45 g	57 g	110 g **

Model	TG-10	ATS-20	ATS-22	ATS-16	ATS-10
<b>System</b>					
Carrier frequency range	863-865 MHz	863-865 MHz	863-865 MHz	863-865 MHz	863-865 MHz
Audio frequency range	40-18,000 Hz	20-3,000 Hz	20-3,000 Hz	200-7,000 Hz	200-10,000 Hz
Transmission method	analogue	digital	digital	analogue	analogue
No. of channels	16	16	16	16	16
LCD	illuminated	x	x	-	-
Display for indicating channel/frequency	x/-	x/-	x/-	-/-	-/-
Display for indicating battery status	x	x	x	x	x
Auto. power off transmitter/receiver	-/-	-/x	-/x	-/-	-/-
Belt clip	x	-	-	x	x
Lanyard	x	x	x	x (optional)	-
Integrated rech. battery	Li-ion 3.7 V/1,300 mA	Li-ion 3.7 V/600 mAh	Li-ion 3.7 V/600 mAh	-	-
1.2 V NiMH rech. batt. AA size	-	-	-	x	x
Battery operation (max., transmitter/receiver) [h]	12 h	15/20	12/15	*	*
Connection for external power supply (transmitter/receiver)	-/-	5 V, micro USB	5 V, micro USB	5 V, 150/150 mA	-/-
Special features	-	-	intercom function	-	-
<b>Transmitter</b>					
	TG-10T/1	ATS-20T	ATS-22T	ATS-16T	ATS-10TM
Built-in microphone/mute function	x/-	-/x	-/x	x/-	x/x
Input for external microphone	x	x	x	x	x
Volume control	x	mic gain, 4-step	mic gain, 4-step	x	x
Channel Sync function	-	x	x	-	-
Line input	-	x	x	x	-
Channel autolock function (transmitter)	x	x	x	mechanically	mechanically
Transmitting power	10 mW	10 mW	10 mW	10 mW	10 mW
Operating range	60 m	100 m	70 m	110 m	190 m
Parallel operation, max. number	3	4	4	8	7
Dimensions transmitter	54 x 99 x 17 mm	40 x 80 x 12 mm	40 x 80 x 12 mm	66 x 111 x 35 mm	92 x 92 x 25 mm
Weight (transmitter w/o rech. batt./batt.)	80 g	37 g **	37 g **	81 g	78 g
<b>Receiver</b>					
	TG-10R/1	ATS-20R	ATS-22R	ATS-16R	ATS-10R
Channel autolock function (receiver)	x	x	x	mechanically	mechanically
Internal antenna (receiver)	x	-	-	x	-
Dimensions receiver	54 x 99 x 17 mm	40 x 87 x 12 mm	40 x 87 x 12 mm	66 x 111 x 35 mm	92 x 92 x 25 mm
Weight (receiver w/o rech. batt./batt.)	80 g	37 g **	37 g **	97 g	85 g

\* Operating time dep. on capacity of rech. batt./batt. \*\* Supplied with rech. batt.



## 42-channel digital PLL voice transmission system, 823-832 MHz and 863-865 MHz

- As a tour guide system also suitable for any other application in which a two-way communication is required, e.g. training sessions, lectures with questions and answers and group tours or factory tours
- High resistance to interference due to digital transmission
- High operating range
- Frequency range optimised for voice transmissions
- Interference-free parallel operation of up to 42 different channels possible

### ATS-80R

Order No. 0250001

#### 42-channel PLL receiver

- Supplied with matching earphone
- Adjustable headphone output
- Automatic switch-off (power-saving function)
- High-contrast OLED display
- Battery status indication
- Push-to-talk button with 3 operating modes (PTT, PTB, PTM)
- Alarm-off button
- Operating range alert
- Call alert
- Mute function
- Automatic channel lock
- Built-in microphone
- Full duplex communication (release by transmitter)
- Hearing Aid Compatible (HAC)

- Belt clip
- Lanyard
- Power supply via 2 x 1.2 V NiMH rech. battery AA size (not supplied)
- Dimensions: 47 x 109 x 35 mm
- Weight: 53 g

**There are restrictions or requirements within the EU!**

**Please read the notes regarding wireless systems in the section "IMPORTANT INFORMATION"!**



### ATS-80T

Order No. 0250002

**42-channel PLL transmitter**, for microphone operation and audio line signals.

- 3 different operating modes: guiding, lecturing and discussions for versatile applications
- Integrated microphone, adjustable gain
- Supplied with additional earphone microphone
- Audio line input via 3.5 mm stereo jack
- High-contrast OLED display
- Battery status indication
- Priority assignment
- Alarm function
- Talk/mute button
- Call button
- Channel lock
- Full-duplex communication
- Attendance monitoring
- Belt clip

- Lanyard
- Adjustable transmitting power (high:  $\leq 20$  mW/ low:  $\leq 10$  mW)
- Operating range: approx. 100 m
- Power supply via 2 x 1.2 V NiMH rech. battery AA size (not supplied)
- Dimensions: 47 x 97 x 35 mm
- Weight: 53 g

**There are restrictions or requirements within the EU!**

**Please read the notes regarding wireless systems in the section "IMPORTANT INFORMATION"!**



## ATS-80ST

Order No. 0179440



**42-channel stationary PLL transmitter**, for microphone operation and audio line signals. In combination with ATS-80R, also suitable for interpretation systems.

- Stereo audio line input via RCA L/R
- Microphone input via comb. jack (XLR/6.3 mm jack)
- Mono audio line output via RCA
- Loop input and loop output via 6.3 mm jack
- Adjustable headphone output for monitoring
- Removable antenna (TNC)
- Supports Bluetooth
- USB audio programming interface
- High-contrast OLED display
- Channel name and ID can be edited

- Adjustable transmitting power (high:  $\leq 20$  mW/ low:  $\leq 10$  mW)
- Operating range: approx. 100 m
- Power is provided via encl. plug-in power supply
- Dimensions: 215 x 51 x 210 mm
- Weight: 1.25 kg

**There are restrictions or requirements within the EU!**

**Please read the notes regarding wireless systems in the section "IMPORTANT INFORMATION"!**



## ATS-80EM

Order No. 0221370

### Earphone microphone

- Suitable for 42-channel PLL transmitter ATS-80T
- Electret headband microphone
- Mono earphone with ring holder for a secure fit
- Clip
- 1 m connection cable with 3.5 mm plug



## ATS-85PS

Order No. 0179470

**Charging station**, for simultaneously charging rech. batteries of up to 5 devices from the ATS-80 series.

- Each slot with LED for indicating battery charging status
- Mechanical reverse polarity protection
- Matrix LCD

- Metal housing
- Including plug-in power supply
- Supplied with programming software for ATS-80R and ATS-80T (SYNC function)



## ATS-825C

Order No. 0179450

**Transport case with integrated charging function and programming function**, for transmitters and receivers from the ATS-80 series.

- For simultaneously charging rech. batteries of up to 25 devices
- Each slot with LED for indicating battery charging status

- Mechanical reverse polarity protection
- Matrix LCD
- Transport case with carrying handle, lockable
- Supplied with matching power supply
- Supplied with programming software for ATS-80R and ATS-80T (SYNC function)

**Supplied w/o devices.**



## ATS-850PS

Order No. 0179460



**Charging station**, for simultaneously charging rech. batteries of up to 50 devices from the ATS-80 series.

- Each slot with LED for indicating battery charging status
- Mechanical reverse polarity protection
- Fan cooling
- Matrix LCD

- Metal housing
- 482 mm (19") rack installation
- Supplied with programming software for ATS-80R and ATS-80T (SYNC function)



# Tour Guide Systems Systems

## Professional PLL Tour Guide System

- Bandwidth: 36 MHz
- 6 groups with up to 22 channels
- 124 channels
- 506-542 MHz
- Operating range: up to 200 m
- Operating time: approx. 10 hours
- There are restrictions or requirements within the EU!

### TG-98TA/5

Order No. 0257410

#### Professional PLL pocket transmitter

- Built-in electret microphone
- 3.5 mm microphone connection
- Supplied with matching electret tie clip microphone
- Audio input via 3.5 mm jack
- LCD for indicating channel/group, RF, mute and battery status
- Lock function
- Mute function
- Volume level control

- Selectable transmitting power
- Belt clip and lanyard
- Parallel operation possible of up to 22 transmitters max.

**There are restrictions or requirements within the EU!**

**Please read the notes regarding wireless systems in the section "IMPORTANT INFORMATION"!**



### TG-98RA/5

Order No. 0257400

#### Professional PLL pocket receiver

- Built-in speaker
- 3.5 mm headphone connection
- Supplied with matching clip-on earphone with rubber ear hook
- Audio output via 3.5 mm jack
- LCD for indicating channel/group, RF and battery status
- Limiter function

- Automatic switch-off (power-saving function)
- Volume level control
- Belt clip and lanyard

**There are restrictions or requirements within the EU!**

**Please read the notes regarding wireless systems in the section "IMPORTANT INFORMATION"!**



### TG-64CH18

Order No. 0259620

**Transport case with integrated charging function**, for transmitters and receivers of the TG-98 series as well as the TG-16 series.

- For simultaneously charging rech. batteries of up to 18 devices
- Average charging time, depending on condition of rechargeable batteries used: approx. 8 hours
- Each slot with LED for indicating battery charging status
- Mechanical reverse polarity protection
- Protection against overload, short-circuit and deep discharge

**Supplied w/o devices.**



## 40-channel Mono PLL Voice Transmission System, 863-865 MHz

- Economy tour guide system
- Due to the narrow-band frequency range which has been perfectly adapted to voice transmissions, a parallel operation of up to 12 different channels is possible without any interference
- Licence-free in the EU

### ATS-50R

Order No. 0255160

#### 40-channel PLL receiver

- Supplied with matching earpiece
- Adjustable headphone output
- Switches off automatically after not receiving an input signal for 20 minutes (power-saving function)
- LCD for indicating channel, carrier signal and battery status
- Autolock function
- Belt clip

- Power supply via 1 x 1.2 V NiMH rech. battery AA size (not supplied)
- Dimensions: 42 x 98 x 24 mm
- Weight: 45 g

**Licence-free in the EU.**



### ATS-50T

Order No. 0255170

**40-channel PLL transmitter**, for microphone operation and audio line signals.

- Integrated microphone
- Supplied with additional electret tie clip microphone
- Audio line input via 3,5 mm stereo jack
- LCD for indicating channel and battery status
- Mute button
- Belt clip
- Transmitting power:  $\leq 10$  mW (EIRP), operating range: approx. 110 m

- Power supply via 1 x 1.2 V NiMH rech. battery AA size (not supplied)
- Dimensions: 42 x 98 x 24 mm
- Weight: 42 g

**Licence-free in the EU.**



### ATS-50PS

Order No. 0250080

**Intelligent PWM quick-charge station**, for simultaneously charging rech. batteries (NC, NiMH) of two devices from the ATS-50 series.

- Average charging time, depending on capacity and condition of the rechargeable batteries used: approx. 3-4 hours, e.g. for 1,300 mAh rech. batteries

- Each slot with LED for indicating a fault and battery charging status
- Mechanical reverse polarity protection
- Including plug-in power supply



### ATS-25C

Order No. 0255180

**Transport case with integrated charging function**, for transmitters and receivers of the ATS-50 series.

- For simultaneously charging rech. batteries of up to 25 devices
- Each slot with LED for indicating battery charging status

- Transport case with carrying handle, lockable
- Supplied with matching power supply
- Dimensions: 442 x 160 x 290 mm
- Weight: 5.2 kg



# Tour Guide Systems Systems

## 40-channel Mono PLL Voice Transmission System, 863-865 MHz

- Economy tour guide system
- Narrow-band frequency range which has been perfectly adapted to voice transmissions. Thus, a parallel operation of up to 12 different channels is possible without any interference
- Licence-free in the EU

### ATS-42R

Order No. 0254560

#### 40-channel PLL receiver

- Including matching clip-on earphone with rubber ear hook
- Adjustable headphone output
- Switches off automatically after not receiving an input signal for 30 minutes (power-saving function)
- LCD for indicating channel and battery status
- Noise squelch
- Channel autolock function
- Lanyard

- Power supply via 2 x 1.2 V NiMH rech. battery AA size (not supplied)
- Dimensions: 66 x 102 x 26 mm
- Weight: 57 g

**Licence-free in the EU.**



### ATS-42T

Order No. 0254570

#### 40-channel PLL transmitter, for microphone applications.

- Supplied with additional electret tie clip microphone
- LCD for indicating channel and battery status
- Channel autolock function
- Lanyard
- Transmitting power:  $\leq 10$  mW (EIRP), operating range: approx. 210 m
- Power supply via 2 x 1.2 V NiMH rech. battery AA size (not supplied)

- Dimensions: 66 x 102 x 26 mm
- Weight: 55 g

**Licence-free in the EU.**



### ES-16

Order No. 0220740

#### Mono earphone

- Flexible rubber ear hook for a secure fit
- Dynamic 32  $\Omega$  system
- 1.2 m connection cable with gold-plated 3,5 mm stereo plug

Model	ES-16
Type of transducer	dynamic
Max. input power	50 mW
Transmission range, headphones	20-20,000 Hz
Nominal impedance, headphones	32 $\Omega$
Headphone sensitivity	105 dB/mW
Cable	1.2 m
Plug	3.5 mm stereo plug
Weight w/o cable	8 g



### ATS-10PS

Order No. 0243530

#### Automatic quick-charge station, for simultaneously charging rech. batteries of two devices from the ATS-10 series.

- Average charging time, depending on capacity and condition of the rechargeable batteries used: approx. 3-4 hours, e.g. for 1,300 mAh rech. batteries

- Operating LEDs for "charging" and "charging completed"
- Including plug-in power supply





## 24-channel mono PLL voice transmission system, 823-832 MHz and 863-865 MHz

- Robust tour guide system, easy to use, with a high operating range and long running time of up to 12 hours
- Well-suited, e.g. for riding lessons

### ATS-60R

Order No. 0257660

#### 24-channel PLL receiver

- Supplied with matching earphone
- Adjustable headphone output
- Switches off automatically (power-saving function)
- LCD for indicating channel, frequency, signal and battery status
- Lock function
- Belt clip
- Power supply via rechargeable lithium-ion battery: 3.7 V/2,400 mAh

- Dimensions: 50 x 102 x 29 mm
- Weight: 110 g

**There are restrictions or requirements within the EU!**

**Please read the notes regarding wireless systems in the section "IMPORTANT INFORMATION"!**



### ATS-60T

Order No. 0257670

#### 24-channel PLL transmitter

- Supplied with electret tie clip microphone
- LCD for indicating channel, frequency, level, signal and battery status
- Belt clip
- Transmitting power
  - 823-832 MHz: ≤50 mW (EIRP), operating range: approx. 300 m
  - 863-865 MHz: ≤10 mW (EIRP), operating range: approx. 240 m
- Power supply via rechargeable lithium-ion battery: 3.7 V/2,400 mAh

- Dimensions: 50 x 102 x 29 mm
- Weight: 112 g

**There are restrictions or requirements within the EU!**

**Please read the notes regarding wireless systems in the section "IMPORTANT INFORMATION"!**



### ATS-60PS

Order No. 0257680

**Charging station**, for simultaneously charging rech. batteries of two devices from the ATS-60 series.

- Each slot with LED for indicating battery charging status
- Mechanical reverse polarity protection
- Including plug-in power supply



### ATS-62C

Order No. 0259100

**Transport case**, for one transmitter and one receiver of the ATS-60 series.

- Additional storage compartments for charging station ATS-60PS and accessories
- Foam-padded interior

Model	ATS-62C
Colour	silver
Outside dimensions	260 x 78 x 210 mm
Weight	890 g

- Aluminium profile frames
- Robust carrying handle
- Plastic corner protection



# Tour Guide Systems Systems

## 16-channel PLL Tour Guide System, 863-865 MHz

- With extensive accessories
- Operating range: up to 60 m
- Parallel operation of up to three wireless transmitters
- Licence-free in the EU

### TG-10R/1

Order No. 0253070

#### PLL pocket receiver

- 3.5 mm headphone connection
- Supplied with matching earphone with rubber ear hook
- Channel selector button
- LED channel indicator
- Volume level control
- Belt clip and lanyard

**Licence-free in the EU.**

Induction loop NL-90 for signal transmission to a hearing device available at option.



### TG-10T/1

Order No. 0253080

#### PLL pocket transmitter

- Built-in electret microphone
- 3.5 mm microphone connection
- Supplied with matching earband microphone CM-801F
- Channel selector button

- LED channel indicator
- Volume level control
- Belt clip and lanyard

**Licence-free in the EU.**



### TG-10STX/1

Order No. 0173730

#### 16-channel PLL wireless transmitter

- 2 inputs (CH1/CH2) via rear comb. jacks, with level controls
- 1 input (CH3) via 6.3 mm mono jack
- Continuously adjustable headphone output

- 2 loop outputs
- Phantom power can be activated as required

**Licence-free in the EU.**



### KA-8TH/1

Order No. 0254410

#### Hand-held UHF PLL transmitter

- Matching the wireless 16-channel PLL audio transmission system for cameras KA-10/1PACK or the PLL pocket receiver TG-10R/1
- Condenser cartridge with cardioid polar pattern
- Adjustable sensitivity

- Mute function
- Battery status indication and LCD for indicating channel

**Licence-free in the EU.**



## TG-10CH2

Order No. 0252670

**Charging station** for transmitters TG-10T/1 and receivers TR-10R/1 as well as for KA-10 components.

- For simultaneously charging rech. batteries of 2 devices
- Average charging time, depending on condition of rechargeable batteries used: approx. 8 hours
- Each slot with LED for indicating battery charging status

- Mechanical reverse polarity protection
- Protection against overload, short-circuit and deep discharge

**Supplied w/o devices.**



## TG-10CH18

Order No. 0252660

**Transport case with integrated charging function**, for transmitters TG-10T/1 and receivers TG-10R/1 as well as for KA-10 components.

- For simultaneously charging rech. batteries of up to 18 devices
- Average charging time, depending on condition of rechargeable batteries used: approx. 8 hours
- Each slot with LED for indicating battery charging status

- Mechanical reverse polarity protection
- Protection against overload, short-circuit and deep discharge

**Supplied w/o devices.**



## TG-10CH36

Order No. 0252680

**Transport case with castors and integrated charging function**, for transmitters TG-10T/1 and receivers TG-10R/1 as well as for KA-10 components.

- For simultaneously charging rech. batteries of up to 36 devices
- Average charging time, depending on condition of rechargeable batteries used: approx. 8 hours
- Each slot with LED for indicating battery charging status
- Mechanical reverse polarity protection

- Protection against overload, short-circuit and deep discharge
- Robust hard-sided plastic transport case with carrying handle
- Due to the integrated telescopic handle and 4 castors, the transport case can easily be pulled like a trolley
- Can be locked via key

**Supplied w/o devices.**



## BAG-ARM/S

Order No. 0236460

### Arm bag

- Suitable for components TG-10T/1 and TG-10R/1 of the tour guide system
- Ideally suited for mobile applications
- Flexible, adjustable strap
- Removable bag with hook and loop fastener



## BAG-BELT/S

Order No. 0236480

### Belt bag

- Suitable for components TG-10T/1 and TG-10R/1 of the tour guide system
- Ideally suited for mobile applications
- Flexible, adjustable strap
- Removable bag with hook and loop fastener



# Tour Guide Systems Systems

## 16-channel Digital Voice Transmission System, 863-865 MHz

- Suitable as a tour guide system, trainer/student system and for any other application in which a certain voice source is to be distributed to one or more receivers
- High resistance to interference due to digital transmission
- Parallel operation of up to 4 different channels possible without any interference
- Licence-free in the EU

### ATS-22R

Order No. 0257110

**16-channel miniature receiver**, with intercom function.

- Intercom function with transmitter ATS-22T via push-button
- Built-in microphone
- Supplied with matching clip-on earphone

- Switches off automatically after not receiving an input signal for 20 minutes (power-saving function)
- LCD for indicating channel, carrier signal, volume and battery status
- Power supply via integrated rech. lithium battery (3.7 V/600 mAh)

- Micro USB charging connection for ATS-12CB, ATS-35CB or USB charger, available at option
- Dimensions: 40 x 87 x 12 mm

**Licence-free in the EU.**



### ATS-22T

Order No. 0257120

**16-channel miniature transmitter**, for microphone operation and audio line signals, with intercom function.

- Supplied with headset
- Activation switch for intercom function with the receiver ATS-22R

- Audio line input via 3,5 mm jack at the headset
- LCD for indicating channel and battery status
- Mute button
- Transmitting power: ≤ 10 mW (EIRP), operating range: approx. 70 m
- Power supply via integrated rech. lithium battery (3.7 V/600 mAh)

- Micro USB charging connection for ATS-12CB, ATS-35CB or USB charger, available at option
- Dimensions: 40 x 80 x 12 mm
- Weight: 37 g

**Licence-free in the EU.**



### ATS-20R

Order No. 0255640

**16-channel miniature receiver**

- Supplied with matching clip-on earphone
- Switches off automatically after not receiving an input signal for 20 minutes (power-saving function)

- LCD for indicating channel, carrier signal, volume and battery status
- Autolock function
- Lanyard
- Power supply via integrated rech. lithium battery (3.7 V/600 mAh)
- Micro USB charging connection for ATS-12CB, ATS-35CB or USB charger, available at option

- Dimensions: 40 x 87 x 12 mm
- Weight: 37 g

**Licence-free in the EU.**



### ATS-20T

Order No. 0255650

**16-channel miniature transmitter**, for microphone operation and audio line signals.

- Supplied with electret tie clip microphone
- Microphone input/audio line input via 3,5 mm jack with automatic detection,

- depending on the configuration (mono/stereo)
- LCD for indicating channel and battery status
- Mute button
- Lanyard
- Transmitting power: ≤ 10 mW (EIRP), operating range: approx. 100 m

- Power supply via integrated rech. lithium battery (3.7 V/600 mAh)
- Micro USB charging connection for ATS-12CB, ATS-35CB or USB charger, available at option
- Dimensions: 40 x 80 x 12 mm
- Weight: 37 g

**Licence-free in the EU.**



### ATS-12CB

Order No. 0255660

**Transport bag with integrated charging function**, for transmitters and receivers of the ATS-20 series.

- For simultaneously charging rech. batteries of up to 12 devices
- Each slot with LED for indicating battery charging status

- Black nylon bag with zip fastener, carrying handle and compartments for accessories
- Supplied with matching power supply
- Dimensions: 350 x 110 x 120 mm
- Weight: 1.03 kg



### ATS-35CB

Order No. 0255670

**Transport bag with integrated charging function**, for transmitters and receivers of the ATS-20 series.

- For simultaneously charging rech. batteries of up to 35 devices
- Each slot with LED for indicating battery charging status

- Black nylon bag with zip fastener, carrying handle and compartments for accessories
- Supplied with matching power supply
- Dimensions: 420 x 140 x 250 mm
- Weight: 2.9 kg



## Professional 16-channel Mono PLL Audio Transmission System, 863-865 MHz

- Suitable as a tour guide system and for any other application in which a certain audio source or voice source is to be distributed to one or more receivers
- Wireless transmissions of audio signals with one transmitter and one receiver are also possible
- Due to small frequency spacing within this free frequency range, simultaneous operation with more than 2 transmitters is not recommended (with optimum conditions, up to 8 transmitters max. are possible)
- Licence-free in the EU

### ATS-16R

Order No. 0244680

#### 16-channel PLL receiver

- Built-in speaker
- Including matching clip-on earphone with rubber ear hook
- Connection for optional audio tube earphone
- Audio output via 3.5 mm stereo jack
- Pilot tone squelch and noise squelch

- Status indication of rech. battery, indication of carrier signal
- Volume level control, belt dip
- Power supply via 2 x 1.2 V NiMH rech. battery AA size (not supplied) or low-voltage jack (5 V)
- Dimensions: 66 x 111 x 35 mm
- Weight: 97 g

Licence-free in the EU.



The hand-held microphone with integrated transmitter ATS-12HT matches the ATS-16 series, available at option.

### ATS-16T

Order No. 0244690

**16-channel PLL transmitter**, for microphone operation and line audio signals.

- Integrated microphone
- Supplied with additional electret tie clip microphone
- Audio line input via 3.5 mm mono jack
- Status indication of rech. battery, indication of carrier signal

- Volume level control, belt clip
- Transmitting power:  $\leq 10$  mW (EIRP), operating range: approx. 110 m
- Power supply via 2 x 1.2 V NiMH rech. battery AA size (not supplied) or low-voltage jack (5 V)
- Dimensions: 66 x 111 x 35 mm
- Weight: 81 g

Licence-free in the EU.



### ATS-16BAG

Order No. 0220720

**Imitation leather protective bag**, for transmitters and receivers of the ATS-16 series.

With belt clip and hook and loop fastener.



### ATS-16CORD

Order No. 0220730

**Lanyard**, for transmitters and receivers of the ATS-16 series. Nylon version.



### ATS-16PS

Order No. 0244670

**Intelligent PWM quick-charge station**, for simultaneously charging rech. batteries (NC, NiMH) of two devices from the ATS-16 series.

- Average charging time, depending on capacity and condition of the rechargeable batteries used: approx. 3-4 hours, e.g. for 1,300 mAh rech. batteries

- Each slot with LED for indicating a fault and battery charging status
- Mechanical reverse polarity protection
- Including plug-in power supply



### ATS-36C

Order No. 0244700

**Transport case with intelligent PWM quick-charge function**, for transmitters and receivers of the ATS-16... series.

- For simultaneously charging rech. batteries (NC, NiMH) of up to 36 devices

- Average charging time, depending on capacity and condition of the rechargeable batteries used: approx. 5-6 hours, e.g. for 1,300 mAh rech. batteries
- Each slot with LED for indicating a fault and battery charging status
- Mechanical reverse polarity protection
- Lockable plastic transport case fitted with castors
- Supplied with matching switch-mode power supply
- Dimensions: 860 x 230 x 350 mm





# Tour Guide Systems Systems

## 16-channel Mono PLL Audio Transmission System, 863-865 MHz

- Suitable as a tour guide system and for any other application in which a certain audio source or voice source is to be distributed to one or more receivers
- Wireless transmissions of audio signals with one transmitter and one receiver are also possible
- Due to the small frequency spacing in this free frequency range, a simultaneous operation of not more than two transmitters is recommended (with optimum conditions, up to 7 transmitters max. are possible)
- Licence-free in the EU

### ATS-10R

Order No. 0243500

**Receiver**, with 3.5 mm mono jack.

- 16 selectable channels
- Built-in speaker
- Including matching clip-on earphone with rubber ear hook
- Status indication of rech. battery
- Operating positions: on/standby/off

- Volume level control, belt clip
- Power supply via 2 x 1.2 V NiMH rech. battery AA size (not supplied)
- Dimensions: 65 x 92 x 25 mm
- Weight: 85 g

**Licence-free in the EU.**



### ATS-10TM

Order No. 0243510

**Transmitter**, for microphone applications.

- 16 selectable channels
- Integrated microphone
- Supplied with additional electret tie clip microphone
- Status indication of rech. battery
- Operating positions: on/standby/off
- Volume level control, belt clip
- Transmitting power:  $\leq 10$  mW (EIRP), operating range: approx. 190 m

- Power supply via 2 x 1.2 V NiMH rech. battery AA size (not supplied)
- Dimensions: 65 x 92 x 25 mm
- Weight: 78 g

**Licence-free in the EU.**



### ATS-12HT

Order No. 0253310

**Hand-held microphone with integrated transmitter**

- Matching the 16-channel mono PLL audio transmission system of the ATS-10 series and ATS-16R
- Electret microphone cartridge, cardioid polar pattern
- 16 selectable channels
- Pilot tone
- Mute function
- Push-to-talk function
- Adjustable transmitting power (high:  $\leq 10$  mW/ low:  $\leq 1$  mW)

- Operating range: approx. 50 m
- LCD for indicating channel and battery status
- Power supply via 2 x 1.2 V NiMH rech. battery AA size (not supplied)
- Dimensions:  $\varnothing 35$  mm x 200 mm
- Weight: 93 g

**Licence-free in the EU.**



### ATS-10BAG

Order No. 0233910

**Protective bag**, for transmitters and receivers of the ATS-10 series. With belt clip.



## ATS-12C

Order No. 0243930

**Transport case with integrated charging function**, for transmitters and receivers of the ATS-10 series.

- For simultaneously charging rech. batteries of up to 12 units
- Each slot with LED for indicating battery charging status

- Wooden case with black imitation leather cover
- Supplied with matching power supply
- Dimensions: 300 x 170 x 280 mm

**Supplied w/o devices.**



## ATS-30C

Order No. 0244320

**Transport case with integrated charging function**, for transmitters and receivers of the ATS-10 series.

- For simultaneously charging rech. batteries of up to 30 devices
- Each slot with LED for indicating battery charging status

- Transport case with black artificial leather cover
- Supplied with matching power supply
- Dimensions: 660 x 170 x 300 mm

**Supplied w/o devices.**



## G-5SET

Order No. 0257070



**Pair of transceivers**, case set, consists of 2 compact transceivers with belt clips, 2 clip-on mics with earphones, 2 plug-in chargers, 2 charging plugs for cigarette lighter sockets, 2 rech. battery packs.

- 8 PMR channels 446 MHz
- 38 CTCSS tones for each channel for interference-free talks
- Monitoring/babysitter function with 18 preset channels
- Out-of-range function
- Hands-free voice-activated transmit function (VOX), 3 levels
- Talk-back function
- Scan function
- Rubber finish

Model	G-5SET
Carrier frequency range	446.00625-446.09375 MHz
Admiss. ambient temp.	-20 °C to +55 °C
Power supply	3 x rech. batt. AAA size, 600 mAh
Dimensions	58 x 98 x 28 mm
Total weight	825 g
Connections	3.5 mm jack (speaker)
Transmitting power	500 mW
Operating range	5 km max.

- Automatic power saving mode saves up to 50%
- Backlit LCD
- Supplied in a transport case

**Licence-free, please refer to the instruction manual on the MONACOR website.**



## G-7SET

Order No. 0250760



**Pair of professional dual-band transceivers**, case set,

consisting of 2 transceivers with belt clip, 2 clip-on mics with earphones, charger for 2 transceivers, 2 rech. battery packs.

- 8 PMR channels 446 MHz
- 69 LPD channels 433 MHz
- Boost function for a wide operating range
- High-performance rech. batteries for high operational availability
- Manual transmit mode (PTT) or hands-free voice-activated transmit mode (VOX)
- Monitoring function
- Automatic squelch
- Channel scan mode (SCAN)
- CTCSS tones
- Dual watch

Model	G-7SET
Carrier frequency range	446.00625-446.09375 MHz (PMR) 433.075-434.775 MHz (LPD)
Admiss. ambient temp.	-20 °C to +55 °C
Power supply	4 x rech. battery AA size, 800 mAh
Dimensions	58 x 195 x 34 mm
Total weight	1.203 kg
Connections	2.5 mm jack (microphone) 3.5 mm jack (speaker)
Transmitting power	500 mW
Operating range	≤ 5,000 m

- Vibracall function
- Key lock
- Backlit LCD
- Supplied in a robust hard-sided case

**Licence-free, please refer to instruction manual on the MONACOR website.**



# Tour Guide Systems Systems

## XT70

Order No. 0259871



**Pair of dual band transceivers**, case set, consisting of 2 transceivers with belt clip, 2 headsets, chargers for 2 transceivers, 2 rechargeable battery packs.

- Pre-programmed channels 446 MHz: 8 PMR and 16 with CTCSS
- 69 LPD channels 433 MHz
- 8 CTCSS tones, 83 DCS tones for interference-free talks
- 9-step hands-free voice-activated function (VOX)
- Operating time of battery: approx. 18 hours

- Monitoring of operating range
- Operating range: up to 12 km
- High/low power (PMR446)
- Babysitter function
- Volume level control
- Supplied in a robust hard-sided case

**Licence-free, please refer to the instruction manual on MONACOR's website.**



## BHS300N

Order No. 0259865



**Basic set**, with push-to-talk transmission button and waterproof plug for connection to a transceiver.

- Double plug for connection of motorcycle headsets COHS with universal connector to PMR transceivers with dual jack, e.g. XT70
- Consists of a waterproof plug-in connector for connection to the helmet set, waterproof talk button which can be attached close at hand, e.g. to the steering wheel or the glove and a connection cable to the transceiver/GPS device or intercom system



## COHS

Order No. 0259867



**Universal headset for motorcycle helmets**, with 2 microphones for full face helmets and jet helmets.

- For connection to the basic set BHS300N
- Cable-connected microphone and gooseneck microphone for mounting to full face helmets or jet/modular helmets
- Increased cable diameter (1.75 mm) and improved cable bending protection
- Waterproof plug with connection cable for basic set



## MULTICOM-3SET

Order No. 0259869

**Multicom transceivers for referees**, case with a set of 3, consists of 3 multicom transceivers, 3 headsets for referees, 3 upper arm bags, 3 USB charging cables, 3 lanyards.

- Wireless full-duplex communication (simultaneous listening and talking) for up to 5 people while another 94 people can listen at the same time
- Cost-efficient use w/o licence fees
- Easy to use: switch on the device, position headset and start communicating
- Operating time: up to 10 hours
- Applicable across Europe (due to 2.4 GHz ISM band)
- Different groups can be set up
- Operating range: up to 200 m

- AES 128-bit encryption
- Clear voice transmission with very low susceptibility to ambient noise
- Adjustable microphone sensitivity
- Splashproof
- Micro USB charging port
- 2 headset jacks
- Intended application:
  - Sport events (e.g. for referees)
  - Concerts and conferences
  - Building sites and industrial use
  - Service sector

**Licence-free in the EU.**



## HS02T

Order No. 0259868

**Professional headset**, with gooseneck microphone and push-to-talk button (PTT).

- Suitable for MULTICOM-3SET
- In-ear earphones ensure a perfect fit
- Higher stability due to supplied ear hook or neckband
- Can be worn on the right or left side
- Innovative switching allows hands-free mode or PTT mode without additional switching at the microphone. Simply switch to hands-free voice activated

transmit mode (VOX) or PTT mode (push-to-talk) at the transceiver

- Supplied with push-to-talk button, 2 ear hooks, 2 earpieces, neckband



## ATT100

Order No. 0259864



**Tour guide transmitter**

- 10+10 pre-programmed channels, channels 1-10 are transmitting with low power (operating range: approx. 200 m), channels 11-20 are transmitting with increased power (PMR446 standard: high operating range of up to 2 km)
- High battery capacity for continuous announcements of up to 6 hours
- Fully programmable (depending on the application)

- 3 different operating modes can be selected:
  - Continuous transmission
  - Voice control
  - Control via push-to-talk buttons (PTT)
- Matching the tour guide receiver ATR200
- Supplied with belt clip, lanyard

**Licence-free, please refer to instruction manual on MONACOR's website.**



## ATR200

Order No. 0259863



**Tour guide receivers**, set of 2.

- 20 pre-programmed channels
- Extra small and ultra-light (approx. 40 g)
- Channel coding
- Anti-noise system (no cracks or loud noise after end of transmission)
- Foolproof operation via 3 buttons only
- Large multifunction LED display (operation, charging, receiving)
- Lock function by means of sliding switch

- Micro USB jack for charging (also via PC)
- Matching the tour guide transmitter ATT100
- Connection for supplied earphones
- Belt clip
- USB charger for simultaneously charging 2 receivers ATR200 in less than 6 hours

**Licence-free, please refer to the instruction manual on MONACOR's website.**



## Highlights

### VERT-12

Order No. 1000157



#### Active column PA speaker system with DSP, 700 W

- Compact full range system with subwoofer and two column modules
- 6 x 7.6 cm (3") bass speaker + 1 x 2.5 cm (1") tweeter in a closed cabinet
- 1 x 30 cm (12") subwoofer in a separate cabinet
- 2-channel class D amplifier system with 300 + 180 W
- DSP-controlled functions for equalizer, limiter and delay
- 4-channel mixer
- 2 x mic/line input, 1 x instrument input (Hi-Z), 1 x stereo line input
- Link and mix outputs
- Bluetooth function for receiving audio files
- High-quality wooden cabinet with protective metal grille
- Wireless plug-in connection of components
- Supplied w/o protective cover set VERT-12BAG, available at option

Model	VERT-12
Transmission method	cable
Total output power	700 W
Power rating (RMS)	DSP-controlled, 480 W (300+180) Bass: 300 W Mid-high range: 180 W
Frequency range	20-20,000 Hz
THD	< 0.06% (sub) < 0.09% (sat)
S/N ratio	-
Input signal	400 mV/10 kΩ (line), 7 mV/40 kΩ (mic, bal.), 50 mV/500 kΩ (Hi-Z) 150 mV/15 kΩ (aux)
Number of speakers	8
Sensitivity	98 dB/W/m
Beam angle	hor.: 120°, vert.: 30°
Power supply	~ 230 V/50 Hz/950 VA
Dimensions	117 x 807 x 124 mm (column speaker) 359 x 576 x 432 mm (subwoofer)
Weight	4.7 kg (column speaker) 3.1 kg (intermediate piece) 20 kg (subwoofer)
Inputs	2 x comb. XLR/6.3 mm (mic/line) 1 x 6.3 mm jack (Hi-Z) 1 x RCA (L/R)
Outputs	2 x XLR, link 1 x XLR, MIX out
Other features	DSP-controlled limiter

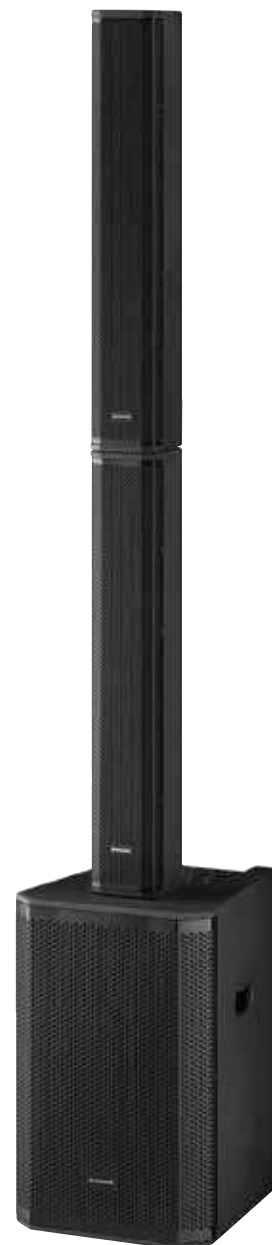

### VERT-12BAG

Order No. 1000158



**Protective cover set**, for VERT-12, consisting of a bag for the satellites and a bag for the subwoofer. With carrying handles and shoulder strap.





## DELTA-160

Order No. 0203190



### 16-channel digital audio mixer

- 12 mono input channels (comb. inputs XLR/6.3 mm jack)
- 2 stereo input channels
- 1 S/PDIF input
- 1 USB audio channel
- USB recording (stereo master) and playback with 192 kHz/24 bits max.
- Integrated DSP (2 x reverb, 2 x modulation, 2 x delay, 2 x 31-band graphic equalizer)
- 8 XLR outputs
- 1 monitor output (6.3 mm jack)
- 1 AES/EBU output
- 1 S/PDIF output
- Can be remote-controlled via app (iOS)
- +48 V phantom power, can be activated as required for each mono input channel

Model	DELTA-160
Mic input	0.4 mV/3 mV, bal. (comb. jack)
Line input	8 mV, bal. (stereo)
Master output	700 mV, bal. (XLR)
Monitor output	700 mV, bal. (6.3 mm jack)
Headphones	> 8 Ω
Frequency range	20-20,000 Hz
THD	< 0.01%
Crosstalk	> 69 dB
Equalizer bass	DSP (4-band equalizer)
Equalizer midrange	DSP (4-band equalizer)
Equalizer treble	DSP (4-band equalizer)
Power supply	via encl. power supply
Dimensions	335 x 140 x 410 mm
Weight	5.55 kg

- 1 adjustable headphone output
- 17.8 cm (7") colour LCD touch screen for display and settings
- Supplied with power supply



## DELTA-160R

Order No. 0203180



### 16-channel digital audio mixer

- 12 mono input channels (8 XLR inputs, 4 comb. inputs XLR/6.3 mm jack)
- 2 stereo input channels
- 1 S/PDIF input
- 1 USB audio channel
- USB recording (stereo master) and playback with 192 kHz/24 bits max.

- Integrated DSP (2 x reverb, 2 x modulation, 2 x delay, 2 x 31-band graphic equalizer)
- 8 XLR outputs
- 1 AES/EBU output
- 1 S/PDIF output
- Can be remote-controlled via app (iOS)
- +48 V phantom power, can be activated as required for each mono input channel

- 1 adjustable headphone output
- 17.8 cm (7") colour LCD touch screen for display and settings
- 482 mm (19") rack installation, 4 RS

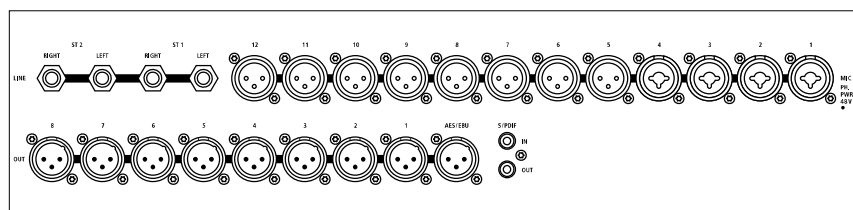

Model	DELTA-160R
Mic input	0.4 mV, bal. (XLR), 0.4 mV/3 mV, bal. (comb. jack)
Line input	8 mV, bal. (stereo)
Master output	700 mV, bal. (XLR)
Headphones	> 8 Ω
Frequency range	20-20,000 Hz
THD	< 0.01%
Crosstalk	> 69 dB
Equalizer bass	DSP (4-band equalizer)
Equalizer midrange	DSP (4-band equalizer)
Equalizer treble	DSP (4-band equalizer)
Power supply	~ 100-240 V/50-60 Hz/45 VA
Dimensions	482 x 180 x 155 mm
Weight	4.62 kg

## RM/DELTA-160

Order No. 0203230

### 482 mm mounting bracket set

- For rack installation of 16-channel digital audio mixer DELTA-160
- 2 mounting brackets
- Black lacquered metal version



## Highlights

### Small, smaller, FLAT

Even if your songs are great, the stages you play on may not always be that great. Little space, modest sound; there are many hurdles which make everyday stage life difficult for an artist. We developed the FLAT monitor series for exactly this scenario: smaller than some shoebox but still with a full and transparent monitor sound for on stage, your rehearsal room and anywhere you need to hear yourself clearly.

#### FLAT-M100

Order No. 0259590



##### Active PA stage monitor speaker system, 200 W

- Flat and very compact full range system
- Fitted with 2 x 10 cm (FaitalPRO, 2 x 4") full range speaker with neodymium magnets
- Class D amplifier system
- Sound pressure at nominal power: 116 dB
- Indication of signal and limiter
- Volume control and tone control
- Balanced line/mic input and feed-through output
- High-quality multiplex wooden cabinet with protective metal grille
- 2 x M10 and 2 x M6 threaded inserts for stand adapter or mounting device
- Supplied with clamp for mounting, e.g. onto a microphone stand

Model	FLAT-M100
Total output power	200 W
Power rating (RMS)	100 W
Frequency range	90-20,000 Hz
Input signal	16 mV/28 k $\Omega$ (line, bal.), 5 mV/20 k $\Omega$ (mic, bal.)
Sensitivity	97 dB/W/m
Housing material	multiplex
Mounting device	2 x M10 threaded insert, 2 x M6 threaded insert
Power supply	~ 230 V/50 Hz/175 VA
Dimensions	265 x 120 x 192.5 mm
Weight	2.4 kg
Inputs	1 x comb. XLR/6.3 mm (line/mic)
Outputs	1 x XLR link out



#### FLAT-M200

Order No. 0259876



##### Active PA stage monitor speaker system, 300 W

- Flat and very compact full range system
- Fitted with 4 x 10 cm (FaitalPRO, 4 x 4") full range speaker with neodymium magnets
- Class D amplifier system
- Sound pressure at nominal power: 122 dB
- Indication of signal and limiter
- Volume control and tone control
- Balanced line/mic input and feed-through output
- High-quality multiplex wooden cabinet with protective metal grille
- 2 x M10 and 2 x M6 threaded inserts for stand adapter or mounting device
- Supplied with clamp for mounting, e.g. onto a microphone stand

Model	FLAT-M200
Total output power	300 W
Power rating (RMS)	200 W
Frequency range	70-20,000 Hz
Input signal	25 mV/28 k $\Omega$ (line, bal.), 6 mV/20 k $\Omega$ (mic, bal.)
Sensitivity	98 dB/W/m
Housing material	multiplex
Mounting device	2 x M10 threaded insert, 2 x M6 threaded insert
Admiss. ambient temp.	0-40 °C
Power supply	~ 230 V/50 Hz/356 VA
Dimensions	320 x 150 x 250 mm
Weight	4.11 kg
Inputs	1 x comb. XLR/6.3 mm (line/mic)
Outputs	1 x XLR link out



## PODCASTER-1

Order No. 0230653

**Recording bundle for podcasters**, consisting of:

- 1 x large diaphragm condenser microphone ECMS-70
- 1 x microphone pop filter KM-23956
- 1 x desktop microphone stand MS-12
- 1 x XLR cable MECN-200/SW, 2 m, NEUTRIK connectors

- 1 x 1-channel USB recording interface MX-110

For additional specifications, please refer to individual items.



## SONGWRITER-1

Order No. 0230654

**Recording bundle for songwriters**, consisting of:

- 1 x large diaphragm condenser microphone ECMS-70 for vocal recordings
- 1 x compact large diaphragm condenser microphone ECMS-60 for recording e.g. acoustic guitars
- 1 x microphone pop filter KM-23956
- 2 x microphone floor stand MS-20/SW

- 2 x XLR cable MECN-600/SW, 6 m, NEUTRIK connectors
- 1 x 2-channel USB recording interface MX-210

For additional specifications, please refer to individual items.



## FLY-16T

Order No. 0259580

**16-channel wireless PA audio transmitter**, with UHF PLL technology.

- For analogue wireless transmission of line audio signals in PA systems
- Frequency range: 823-832 MHz
- 16 pre-programmed channels, selectable
- Up to 8 intermodulation-free channels
- Indication for channel and battery status
- Supplied with USB cable

Model	FLY-16T
Description	16-channel wireless PA audio transmitter
Carrier frequency range	823-832 MHz
Audio frequency range	30-17,000 Hz
THD	0.3%
Admiss. ambient temp.	0-40 °C
Transmitting power	10 mW
Operating range	approx. 90 m
Power supply transmitter	1 x 1.5 V batt. AA size, = 5 V/150 mA via micro USB jack
Dimensions transmitter	22 x 23 x 116 mm
Weight transmitter	54 g
Connections transmitter	3-pole XLR jack



## FLY-16R

Order No. 0259570

**16-channel wireless PA audio receiver**, with UHF PLL technology.

- For analogue wireless transmission of line audio signals in PA systems
- Frequency range: 823-832 MHz
- 16 pre-programmed channels, selectable
- Up to 8 intermodulation-free channels
- Multiple receivers FLY-16R can be operated via one transmitter FLY-16T

Model	FLY-16R
Description	16-channel wireless PA audio receiver
Carrier frequency range	823-832 MHz
Audio frequency range	30-17,000 Hz
THD	0.3%
Admiss. ambient temp.	0-40 °C
Power supply receiver	1 x 1.5 V batt. AA size, = 5 V/150 mA via micro USB jack
Dimensions receiver	22 x 23 x 102 mm
Weight receiver	25 g
Connections receiver	3-pole XLR plug

- Indication for channel and battery status
- Supplied with USB cable



## FLY-16SET

Order No. 0259854

**16-channel wireless PA audio transmission set**, with UHF PLL technology.

- Consisting of 16-channel wireless PA audio transmitter FLY-16T and 16-channel wireless PA audio receiver FLY-16R
- For analogue wireless transmission of line audio signals in PA systems

- Frequency range: 823-832 MHz
- 16 pre-programmed channels, selectable
- Up to 8 intermodulation-free channels
- Audio transmission range: 30-17,000 Hz
- Compact size
- For further specifications, please refer to individual items



**There are restrictions or requirements in the EU!**

**Please read the notes on wireless systems in the section "IMPORTANT INFORMATION"!**

# Microphones

## Large Diaphragm Microphones

### ECMS-90

Order No. 0236970

**Large diaphragm condenser microphone**, for professional studio applications.

- 2.8 cm (1.1") extra thin gold-plated diaphragm
- Low cut switch
- 10 dB attenuation, switchable
- 48 V phantom power
- Supplied with vibration absorbing support (spider) with 16 mm (5/8") tripod socket and 9 mm (3/8") adapter screw, microphone windshield and leather bag
- Supplied in a foam-padded case

Model	ECMS-90
Polar pattern	cardioid
System	condenser
Audio frequency range	20-20,000 Hz
Nominal impedance	200 Ω
Sensitivity	20 mV/Pa
S/N ratio	78 dB
Max. sound pressure	135 dB
Power supply	= 48 V, phantom power
Housing material	metal
Dimensions	Ø 50 mm x 185 mm
Weight	430 g
Connection	XLR, bal.



### ECMS-70

Order No. 0236960

**Large diaphragm condenser microphone**, for professional studio applications.

- 2.5 cm (1") extra thin gold-plated diaphragm
- 48 V phantom power
- Supplied with vibration absorbing support (spider) with 16 mm (5/8") tripod socket and 9 mm (3/8") adapter screw, microphone windshield and leather bag

Model	ECMS-70
Polar pattern	cardioid
System	condenser
Audio frequency range	20-20,000 Hz
Nominal impedance	150 Ω
Sensitivity	20 mV/Pa
S/N ratio	78 dB
Max. sound pressure	132 dB
Power supply	= 48 V, phantom power
Housing material	metal
Dimensions	Ø 50 mm x 185 mm
Weight	310 g
Connection	XLR, bal.



### ECMS-60

Order No. 0236950

**Large diaphragm condenser microphone**, for professional studio applications.

- Compact design
- 2.5 cm (1") extra thin gold-plated diaphragm
- 48 V phantom power
- Supplied with microphone support with 16 mm (5/8") tripod socket and 9 mm (3/8") adapter screw and leather bag

Model	ECMS-60
Polar pattern	cardioid
System	FET condenser
Audio frequency range	20-20,000 Hz
Nominal impedance	200 Ω
Sensitivity	17.8 mV/Pa
S/N ratio	> 70 dB
Max. sound pressure	125 dB
Power supply	= 48 V, phantom power
Housing material	metal
Dimensions	Ø 50 mm x 130 mm
Weight	290 g
Connection	XLR, bal.



### ECMS-50USB

Order No. 0236940



**Large diaphragm USB condenser microphone**, for ambitious home recording.

- For operating directly at a PC or laptop
- No driver installation required, device will be identified automatically
- Integrated high-quality A/D converter: 48 kHz/16 bits
- 2.5 cm (1") extra thin gold-plated diaphragm
- Supplied with vibration absorbing support (spider) with 16 mm (5/8") tripod socket and 9 mm (3/8") adapter screw, 1.8 m USB connection cable and leather bag
- Suitable for Windows\* 2000/XP/Vista/7/8/10 or Mac OS\* X

Model	ECMS-50USB
Polar pattern	cardioid
System	electret condenser
Audio frequency range	20-18,000 Hz
Sensitivity	25 mV/Pa
S/N ratio	> 78 dB
Max. sound pressure	138 dB
Power supply	= 5 V via USB interface
Housing material	metal
Dimensions	Ø 50 mm x 185 mm
Weight	250 g
Cable	1.8 m
Connection	USB Type-B jack



### MX-110

Order No. 0203160



#### 1-channel USB recording interface

- Integrated USB audio interface (will be identified and addressed as an external sound card)
- Full-duplex USB port (allows for simultaneous recording and reproduction) for reproduction of digital audio data from a PC and for recording mixings onto a PC
- 1 mono input channel with XLR input (mic) and 6.3 mm input (switchable mic/line)
- Selectable 20 dB attenuation and LED level display
- 1 additional stereo input
- 1 x 6.3 mm jack output L/R
- 1 x 3.5 mm stereo jack output
- Adjustable headphone output
- +48 V phantom power, can be activated as required
- Stereo LED level display
- Robust metal housing of compact size

Model	MX-110
Mic input	2.5 mV, 1 x 3-pole XLR
Line input	45 mV, 1 x 6.3 mm jack
	11 kΩ (line)/460 kΩ (inst.)
Aux input	1.25 V, 1 x 3.5 mm jack
Master output	500 mV, 1 x 6.3 mm jack L/R
Aux output	500 mV, 1 x 3.5 mm jack
Headphones	≥ 16 Ω, 1 x 3.5 mm jack
Frequency range	20-20,000 Hz
THD	≤ 0.03%
Crosstalk	92 dB
Power supply	via USB interface = 5 V/500 mA
Dimensions	120 x 50 x 110 mm
Weight	498 g



### MX-210

Order No. 0203170



#### 2-channel USB recording interface

- Integrated USB audio interface (will be identified and addressed as an external sound card)
- Full-duplex USB port (allows for simultaneous recording and reproduction) for reproduction of digital audio data from a PC and for recording mixings onto a PC
- 2 mono input channels with XLR input (mic) and 6.3 mm input (switchable mic/line)
- Selectable 20 dB attenuation and LED level display
- Input channels switchable mono/stereo
- 1 additional stereo input
- 1 x 6.3 mm jack output L/R
- 1 x 3.5 mm jack stereo output
- Adjustable headphone output

Model	MX-210
Mic input	2.5 mV, 2 x 3-pole XLR
Line input	45 mV, 1 x 6.3 mm jack
	11 kΩ (line)/460 kΩ (inst.)
Aux input	1.25 V, 1 x 3.5 mm jack
Master output	500 mV, 2 x 6.3 mm jack L/R
Aux output	500 mV, 1 x 3.5 mm jack
Headphones	≥ 16 Ω, 1 x 3.5 mm jack
Frequency range	20-20,000 Hz
THD	≤ 0.03%
Crosstalk	92 dB
Power supply	via USB interface = 5 V/500 mA
Dimensions	160 x 50 x 110 mm
Weight	634 g

- +48 V phantom power, can be activated as required for each channel
- Stereo LED level display
- Robust metal housing of compact size



# Microphones

## Vocal Microphones

### DM-9

Order No. 0237211

**Dynamic microphone**, for stage and vocals.

- Supercardioid polar pattern
- Neodymium version
- Active Handling Noise Cancelling technology (AHNC) for minimising handling noise
- Humbucker coil for minimising electromagnetic interference
- Aluminium body
- Supplied with microphone holder

Model	DM-9
Polar pattern	supercardioid
System	dynamic
Audio frequency range	50-18,000 Hz
Nominal impedance	600 Ω
Sensitivity	2 mV/Pa
Max. sound pressure	142 dB
Housing material	aluminium
Dimensions	Ø 55 mm x 181 mm
Weight	330 g
Connection	XLR, bal.



### DM-9S

Order No. 0237212

**Dynamic microphone**, for stage and vocals.

- Supercardioid polar pattern
- Neodymium version
- Active Handling Noise Cancelling technology (AHNC) for minimising handling noise
- Humbucker coil for minimising electromagnetic interference
- Innovative, low-noise slide potentiometer switch
- Aluminium body
- Supplied with microphone holder

Model	DM-9S
Polar pattern	supercardioid
System	dynamic
Audio frequency range	50-18,000 Hz
Nominal impedance	600 Ω
Sensitivity	2 mV/Pa
Max. sound pressure	142 dB
Housing material	aluminium
Dimensions	Ø 55 mm x 181 mm
Weight	330 g
Connection	XLR, bal.





### DM-7

Order No. 0237210

**Dynamic microphone**, for stage and vocals.

- Supercardioid polar pattern
- Metal body
- Supplied with microphone holder, 9 mm ( $\frac{3}{8}$ " ) adapter screw and microphone bag

Model	DM-7
Polar pattern	supercardioid
System	dynamic
Audio frequency range	50-18,000 Hz
Nominal impedance	250 $\Omega$
Sensitivity	1.8 mV/Pa
Max. sound pressure	130 dB
Housing material	metal
Dimensions	$\varnothing$ 51 mm x 182 mm
Weight	315 g
Connection	XLR, bal.



### CM-7

Order No. 0237200

**Condenser microphone**, for studio and live applications.

- 17 mm gold-plated small diaphragm
- Cardioid polar pattern
- Metal body
- Supplied with microphone holder, 9 mm ( $\frac{3}{8}$ " ) adapter screw and microphone bag

Model	CM-7
Polar pattern	cardioid
System	condenser
Audio frequency range	50-18,000 Hz
Nominal impedance	100 $\Omega$
Sensitivity	14 mV/Pa
Max. sound pressure	137 dB
Power supply	= 48 V, phantom power
Housing material	metal
Dimensions	$\varnothing$ 51 mm x 182 mm
Weight	280 g
Connection	XLR, bal.



### DM-3

Order No. 0237220

**Dynamic microphone**, for stage, speech and vocals.

- Supercardioid polar pattern
- Neodymium version
- Diecast zinc body
- Supplied with microphone holder, 9 mm ( $\frac{3}{8}$ " ) adapter screw and microphone bag

Model	DM-3
Polar pattern	supercardioid
System	dynamic
Audio frequency range	50-15,000 Hz
Nominal impedance	600 $\Omega$
Sensitivity	2.2 mV/Pa
Housing material	diecast zinc
Dimensions	$\varnothing$ 53 mm x 177 mm
Weight	255 g
Connection	XLR, bal.



### DM-3S

Order No. 0237230

**Dynamic microphone**, for stage, speech and vocals.

- Supercardioid polar pattern
- Neodymium version
- Low-noise on/off switch
- Diecast zinc body
- Supplied with microphone holder, 9 mm ( $\frac{3}{8}$ " ) adapter screw and microphone bag

Model	DM-3S
Polar pattern	supercardioid
System	dynamic
Audio frequency range	50-15,000 Hz
Nominal impedance	600 $\Omega$
Sensitivity	2.2 mV/Pa
Housing material	diecast zinc
Dimensions	$\varnothing$ 53 mm x 177 mm
Weight	255 g
Connection	XLR, bal.



# Microphones

## Vocal Microphones

### DM-101

Order No. 0236550

**Dynamic microphone**, vintage style.

- Supercardioid polar pattern
- Dual microphone cartridges for an authentic sound
- Innovative cartridge suspension with excellent attenuation characteristics
- Robust zinc body of high quality
- Low-noise on/off switch

Model	DM-101
Polar pattern	supercardioid
System	dynamic
Audio frequency range	50-12,000 Hz
Nominal impedance	1,2 k $\Omega$
Sensitivity	5 mV/Pa
Max. sound pressure	119 dB
Housing material	zinc alloy
Dimensions	204 x 68 x 74 mm
Weight	740 g
Connection	XLR, bal.



### DM-065

Order No. 0235740

**Nostalgic dynamic microphone**, retro look of the 50s/60s.

- For stage, speech and vocals
- Cardioid polar pattern
- Low-noise on/off switch
- Chromium-plated version
- Supplied with foam-padded plastic case

Model	DM-065
Polar pattern	cardioid
System	dynamic
Audio frequency range	50-16,000 Hz
Nominal impedance	250 $\Omega$
Sensitivity	1,3 mV/Pa
Max. sound pressure	135 dB
Housing material	metal, silver
Dimensions	54 x 175 x 68 mm
Weight	547 g
Connection	XLR, bal.



### DM-5000LN

Order No. 0230400

**Dynamic microphone**, for stage and vocals.

- Supercardioid polar pattern
- Highly sensitive neodymium magnet version
- Supplied with microphone holder, cable and case

Model	DM-5000LN
Polar pattern	supercardioid
System	dynamic
Audio frequency range	40-18,000 Hz
Nominal impedance	250 $\Omega$
Sensitivity	2,5 mV/Pa
Max. sound pressure	130 dB
Housing material	diecast zinc
Dimensions	$\varnothing$ 53,5 mm x 174 mm
Weight	690 g
Cable	6 m, low-noise, XLR
Connection	XLR, bal.



## DM-1100

Order No. 0233290

**Dynamic microphone**, for speech and vocals.

- Cardioid polar pattern
- Supplied with cable
- Supplied w/o microphone holder. Matching microphone holder (e.g. MH-202) is available at option

Model	DM-1100
Polar pattern	cardioid
System	dynamic
Audio frequency range	50-16,000 Hz
Nominal impedance	500 Ω
Sensitivity	2,5 mV/Pa
Max. sound pressure	145 dB
Housing material	metal
Dimensions	Ø 54 mm x 175 mm
Weight	250 g
Cable	5 m, low-noise, 6.3 mm plug
Connection	XLR, bal.



## DM-3SET

Order No. 0234020

**Dynamic vocal microphone set**

Set of 3 vocal microphones, ideally suited for recordings and live performances. The frequency response has been especially optimised for vocal applications which makes the DM-3SET a reliable tool for any vocalist.

- Wide transmission range
- Very low acoustic feedback
- Integrated windshield/pop noise head
- Suitable for on-the-road applications due to diecast body and steel basket
- Supplied accessories: robust hard-sided case, 3 x stand clamp 16 mm (5/8")

Model	DM-3SET
Polar pattern	cardioid
System	dynamic
Audio frequency range	50-15,000 Hz
Nominal impedance	500 Ω
Sensitivity	2 mV/Pa
Max. sound pressure	120 dB
Housing material	diecast zinc
Dimensions	Ø 53 mm x 180 mm
Weight	285 g
Connection	XLR, bal.



# Microphones

## Instrument Microphones

### DRUMSET-1

Order No. 0231390

**7-piece drum microphone set**, consisting of a dynamic bass drum microphone, four dynamic snare drum/tom-tom microphones and two overhead condenser microphones.

- Optimised for sound pickup of drums
- Short-bodied microphones
- Including microphone holder with 16 mm ( $\frac{5}{8}$ " ) tripod socket and 9 mm ( $\frac{3}{8}$ " ) adapter screw for every microphone
- Additional clamps for the snare drum/tom-tom microphones
- Supplied in a practical plastic case

Model	DRUMSET-1
Polar pattern	bi-directional (bass drum) supercardioid (snare drum/tom-tom) cardioid (overhead)
System	dynamic (bass drum) dynamic (snare drum/tom-tom) electret (overhead)
Audio frequency range	50-10,000 Hz (bass drum) 50-15,000 Hz (snare drum/tom-tom) 50-15,000 Hz (overhead)
Nominal impedance	200 $\Omega$
Sensitivity	1,6 mV/Pa (bass drum) 2,5 mV/Pa (snare drum/tom-tom) 5,6 mV/Pa (overhead)
S/N ratio	66 dB
Max. sound pressure	158 dB (bass drum) 157 dB (snare drum/tom-tom) 161 dB (overhead)
Power supply	= 48 V, phantom power (overhead)
Dimensions	$\varnothing$ 50 mm x 113 mm (bass drum) $\varnothing$ 40 mm x 93 mm (snare drum/tom-tom) $\varnothing$ 22 mm x 90 mm (overhead) 430 x 135 x 320 mm (set)
Weight	1,5 kg
Connection	XLR, bal.



### ECM-250

Order No. 0233480

**Electret microphone set**, consisting of two overhead electret microphones.

- Optimised for sound pickup of drum combinations and percussion instruments
- Short-bodied microphones
- Low cut switch, selectable 10 dB attenuation
- 48 V phantom power
- Including microphone holder with 16 mm ( $\frac{5}{8}$ " ) tripod socket and 9 mm ( $\frac{3}{8}$ " ) adapter screw
- Supplied in a practical plastic case

Model	ECM-250
Polar pattern	cardioid
System	electret
Audio frequency range	50-16,000 Hz
Nominal impedance	200 $\Omega$
Sensitivity	18/5,6 mV/Pa
S/N ratio	66 dB
Max. sound pressure	130 dB
Power supply	= 48 V, phantom power
Dimensions	$\varnothing$ 19 mm x 80 mm
Weight	25 g
Connection	XLR, quasi-balanced



### ECM-310W

Order No. 0233360

**Electret microphone for sound pickup of wind instruments**

- 8 cm gooseneck
- Phantom power via supplied adapter
- 3 m connection cable with 3-pole mini XLR/XLR
- Supplied in a practical plastic case

Model	ECM-310W
Polar pattern	supercardioid
System	electret
Audio frequency range	30-17,000 Hz
Nominal impedance	200 $\Omega$
Sensitivity	4,5 mV/Pa
Max. sound pressure	120 dB
Power supply	9-48 V via power supply adapter
Dimensions	140 mm
Weight	155 g
Cable	3 m
Connection	3-pole mini XLR, unbal. adapter: XLR, bal.



### ECM-270

Order No. 0235140

**Professional condenser microphone**, for studio applications and live performances. Ideally suited for direct or overhead sound pickup of acoustic instruments and vocals.

- Back electret cartridge with cardioid polar pattern
- Low cut switch
- Selectable 10 dB attenuation
- Electronically balanced output
- Robust brass body of high quality
- Supplied accessories: robust hard-sided case, microphone windshield, microphone support (spider) for 16 mm (5/8") stand

Model	ECM-270
Polar pattern	cardioid
System	back electret
Audio frequency range	50-18,000 Hz
Nominal impedance	200 Ω
Sensitivity	5.6 mV/Pa
S/N ratio	> 60 dB
Max. sound pressure	135 dB
Power supply	≙ 48 V, phantom power
Housing material	brass
Dimensions	Ø 20 mm x 150 mm
Weight	140 g
Connection	XLR, bal.



### ECM-285

Order No. 0232760

**Electret microphone for sound pickup of vocals and instruments**

- Special shock-absorbing cartridge support
- Operation via external phantom power (≙ 9-48 V) or internal 1.5 V battery
- ON/OFF switch
- Supplied with 6 m connection cable XLR/XLR and support with screw fixing 16 mm (5/8")/9 mm (3/8")

Model	ECM-285
Polar pattern	cardioid
System	electret
Audio frequency range	80-15,000 Hz
Nominal impedance	400 Ω
Sensitivity	5 mV/Pa
Max. sound pressure	115 dB
Power supply	1 x 1.5 V batt. AA size or ≙ 9-48 V (phantom power)
Dimensions	Ø 26 mm x 195 mm
Weight	110 g
Cable	6 m
Connection	XLR, bal.



### ECM-40

Order No. 0232230

**Universal electret microphone**, with linear frequency response.

- For measuring systems and audio recordings
- Supplied with frequency graph

Model	ECM-40
Polar pattern	omnidir.
System	electret
Audio frequency range	30-18,000 Hz
Nominal impedance	500 Ω
Sensitivity	5.6 mV/Pa
S/N ratio	> 60 dB
Max. sound pressure	120 dB
Power supply	≙ 12-48 V, phantom power
Housing material	metal
Dimensions	Ø 13/19 mm x 158 mm
Weight	50 g
Cable	6 m
Connection	XLR, bal.



# Microphones Accessories

## EMA-200

Order No. 0232790

### 48 V phantom power supply

- For 2 electret microphones or microphone cartridges
- Power supply: ~ 230 V/50 Hz/10 VA
- 2 x XLR input (bal.)
- 2 x XLR output (bal.)

Model	EMA-200
Input voltage	~ 230 V/50 Hz/10 VA
Output voltage	+48 V
Connections	2 x XLR, bal.
Dimensions	180 x 50 x 145 mm
Weight	1,179 kg



## EMA-3

Order No. 0233820

### 48 V phantom power supply

- For electret microphones and microphone cartridges
- XLR input (bal.)
- XLR output (bal.)

Model	EMA-3
Input voltage	via encl. plug-in power supply
Output voltage	+48 V
Dimensions	126 x 75 x 45 mm
Weight	535 g



## EMA-1

Order No. 0232120

### Phantom power supply adapter

- For electret microphones and electret microphone cartridges
- Also to be used as a phantom power adapter for mixers with phantom power supply +48 V
- Internal power supply via 1.5 V battery AA size (not supplied)
- 3-pole mini XLR input
- 3-pole XLR output

Model	EMA-1
Input voltage	phantom power via mixer: = 48 V
Connections	3-pole XLR
Dimensions	Ø 22 mm x 170 mm
Weight	75 g



## EMA-300P

Order No. 0232410

### Phantom power supply adapter

- For connecting ECM-300B, ECM-300L and other microphones with 3-pole mini XLR connector to a mixer with 48 V phantom power
- Mini XLR plug and XLR plug, 3 poles

Model	EMA-300P
Input voltage	via mixer
Connections	3-pole mini XLR
Dimensions	Ø 19 mm x 92 mm
Weight	79 g





## WSA-24R

Order No. 0257140

**Wireless stereo receiver, 2.4 GHz**, for audio streaming.

- Matching the transmitter WSA-24T
- Interference-free operation due to FHSS technology (Frequency Hopping Spread Spectrum)
- Analogue line level output via 6.3 mm jacks L/R
- Plastic housing
- Power is provided via enclosed plug-in power supply

Model	WSA-24R
Frequency range	20-20,000 Hz
THD	< 0.3%
Channel separation	≥ 90 dB
Power supply	via encl. power supply
Dimensions	116 x 35 x 86 mm
Weight	118 g
Connections	Outputs: 1 x 6.3 mm stereo jack L/R, analogue



## WSA-24T

Order No. 0257150

**Wireless stereo transmitter, 2.4 GHz**, for audio streaming.

- Matching the receiver WSA-24R
- Stereo/mono selector switch
- LED for indicating status and peak
- Interference-free operation due to FHSS technology (Frequency Hopping Spread Spectrum)
- Analogue line level input via 6.3 mm jacks L/R and 3-pole XLR L/R
- Metal housing
- Power is provided via enclosed plug-in power supply

Model	WSA-24T
Frequency range	20-20,000 Hz
THD	< 0.3%
Channel separation	≥ 90 dB
Operating range	> 30 m with clear view
Power supply	via encl. power supply
Dimensions	130 x 54 x 130 mm
Weight	470 g
Connections	Inputs: 1 x 6.3 mm stereo jack L/R, analogue 1 x 3-pole XLR L/R, analogue



# Microphones

## Wireless Transmission

### TXS-606

Order No. 0253510

**Multifrequency receiver unit**, with UHF PLL technology.

- 1,000 selectable UHF frequencies (672.000-696.975 MHz) in 10 groups with 100 frequencies each
- ACT function for transmitting selected frequency to pocket transmitter TXS-606LT or hand-held microphone TXS-606HT via infrared signal
- Auto-scan
- True diversity system with removable antennas (BNC connection)

Model	TXS-606
Carrier frequency range	672.000-696.975 MHz
Audio frequency range	30-18,000 Hz
THD	< 0.5%
Dynamic range	100 dB
RF S/N ratio	105 dB
Admiss. ambient temp.	0-40 °C
Audio signal receiver	350 mV/600 Ω (jack) 25 mV/600 Ω (XLR, bal.)
Power supply receiver	via encl. plug-in power supply
Dimensions receiver	212 x 45 x 180 mm
Weight receiver	930 g
Connections receiver	1 x XLR, bal., 1 x 6.3 mm jack, unbal.

- Volume and squelch controls



### TXS-626

Order No. 0253520



**2-channel multifrequency receiver unit**, with UHF PLL technology.

- 1,000 selectable UHF frequencies (672.000-696.975 MHz) for each channel (10 groups with 100 frequencies each)
- ACT function for transmitting selected frequency to pocket transmitter TXS-606LT or hand-held microphone TXS-606HT via infrared signal
- Auto-scan
- True diversity system with removable antennas (BNC connection)
- Volume and squelch controls for each channel

Model	TXS-626
Carrier frequency range	672.000-696.975 MHz
Audio frequency range	30-18,000 Hz
THD	< 0.5%
Dynamic range	100 dB
RF S/N ratio	105 dB
Admiss. ambient temp.	0-40 °C
Audio signal receiver	350 mV/600 Ω (jack) 25 mV/600 Ω (XLR, bal.)
Power supply receiver	via encl. plug-in power supply
Dimensions receiver	482 x 45 x 195 mm
Weight receiver	1.8 kg
Connections receiver	2 x XLR, bal., 1 x 6.3 mm jack, unbal.



### TXS-646

Order No. 0253530



**4-channel multifrequency receiver unit**, with UHF PLL technology.

- 1,000 selectable UHF frequencies (672.000-696.975 MHz) for each channel (10 groups with 100 channels each)
- ACT function for transmitting selected frequency to pocket transmitter TXS-606LT, TXS-606HSE or hand-held microphone TXS-606HT via infrared signal
- Auto-scan
- True diversity system with removable antennas (BNC connection)

Model	TXS-646
Carrier frequency range	672.000-696.975 MHz
Audio frequency range	30-18,000 Hz
THD	< 0.5%
Dynamic range	100 dB
RF S/N ratio	105 dB
Admiss. ambient temp.	0-40 °C
Audio signal receiver	350 mV/600 Ω (jack) 25 mV/600 Ω (XLR, bal.)
Power supply receiver	via encl. plug-in power supply
Dimensions receiver	482 x 45 x 310 mm
Weight receiver	2.9 kg
Connections receiver	4 x XLR, bal., 1 x 6.3 mm jack, unbal.

- Volume and squelch controls for each channel



### TXS-686

Order No. 0257320



**8-channel multifrequency receiver unit**, with UHF PLL technology.

- 1,000 selectable UHF frequencies (672.000-696.975 MHz) for each channel (10 groups with 100 channels each)
- ACT function for transmitting selected frequency to pocket transmitter TXS-606LT, TXS-606HSE, hand-held microphone TXS-606HT or desktop microphone TXS-606DT via infrared signal
- Auto-scan
- True diversity system with removable antennas (BNC connection)
- Volume and squelch controls for each channel

Model	TXS-686
Carrier frequency range	672.000-696.975 MHz
Audio frequency range	30-18,000 Hz
THD	< 0.5%
Dynamic range	100 dB
RF S/N ratio	105 dB
Admiss. ambient temp.	0-40 °C
Audio signal receiver	350 mV/600 Ω (jack) 25 mV/600 Ω (XLR, bal.)
Power supply receiver	via encl. plug-in power supply
Dimensions receiver	482 x 90 x 310 mm
Weight receiver	4.4 kg
Connections receiver	8 x XLR, bal., 1 x 6.3 mm jack, unbal.



## TXS-606HT/2

Order No. 1000185

**Hand-held microphone with integrated multi-frequency transmitter**, with UHF PLL technology.

- Dynamic microphone cartridge, cardioid polar pattern
- 800 selectable UHF frequencies (672.000-691.975 MHz), can be synchronised with receivers TXS-606, TXS-626, TXS-646 or TXS-686 via ACT function
- Adjustable sensitivity
- Switchable transmitting power (high: 25 mW/ low: 2.5 mW)

Model	TXS-606HT
Polar pattern	cardioid
System	dynamic
Carrier frequency range	672.000-691.975 MHz
Transmitting power	25 mW/2.5 mW
Power supply	2 x 1.5 V batt. AA size
Operating time	> 8 h
Audio frequency range	30-18,000 Hz
Dimensions	Ø 51 mm x 265 mm
Weight	312 g

- LCD for indicating group/channel, audio level and battery status



## TXS-606HSE/2

Order No. 1000184

**Multifrequency pocket transmitter**, with UHF PLL technology.

- 800 selectable UHF frequencies (672.000-691.975 MHz), can be synchronised with receivers TXS-606, TXS-626, TXS-646 or TXS-686 via ACT function
- Continuously adjustable sensitivity
- LCD for indicating group/channel, audio level and battery status
- Suitable for combination with headband/earband microphones and tie clip microphones with 3-pole mini XLR connector

Model	TXS-606HSE
Carrier frequency range	672.000-691.975 MHz
Audio frequency range	30-18,000 Hz
Operating time	> 8 h
Admiss. ambient temp.	0-40 °C
Transmitting power	10 mW
Power supply transmitter	2 x 1.5 V batt. AA size
Dimensions transmitter	61 x 106 x 27 mm
Weight transmitter	80 g
Connections transmitter	1 x 3-pole mini XLR



## TXS-606LT/2

Order No. 1000186

**Multifrequency tie clip microphone transmitter**, with UHF PLL technology.

- 800 selectable UHF frequencies (672.000-691.975 MHz), can be synchronised with receivers TXS-606, TXS-626, TXS-646 or TXS-686 via ACT function
- Continuously adjustable sensitivity
- LCD for indicating group/channel, audio level and battery status
- Tie clip microphone with latchable 3.5 mm plug

Model	TXS-606LT
Carrier frequency range	672.000-691.975 MHz
Audio frequency range	30-18,000 Hz
Operating time	> 8 h
Admiss. ambient temp.	0-40 °C
Transmitting power	10 mW
Power supply transmitter	2 x 1.5 V batt. AA size
Dimensions transmitter	61 x 106 x 27 mm
Weight transmitter	96 g
Connections transmitter	1 x 3.5 mm jack



## TXS-606DT/2

Order No. 1000183

**Wireless desktop microphone with integrated multifrequency transmitter**, with UHF PLL technology.

- Electret microphone cartridge, cardioid polar pattern
- 350 mm gooseneck, removable
- 800 selectable UHF frequencies (672.000-691.975 MHz), can be synchronised with receivers TXS-606, TXS-626, TXS-646 or TXS-686 via ACT function
- Adjustable sensitivity
- Switchable transmitting power (high: 25 mW/ low: 2.5 mW)

Model	TXS-606DT
Polar pattern	cardioid
System	electret
Carrier frequency range	672.000-691.975 MHz
Transmitting power	25 mW/2.5 mW
Power supply	2 x 1.5 V batt. AA size
Operating time	> 8 h
Audio frequency range	30-18,000 Hz
Dimensions	120 x 65 x 178 mm (w/o gooseneck)
Weight	1.2 kg

- LCD for indicating group/channel, audio level and battery status



**There are restrictions or requirements in the EU!**

**Please read the notes on wireless systems in the section "IMPORTANT INFORMATION"!**

# Microphones

## Wireless Transmission

### TXS-900HT

Order No. 0255260

**Hand-held microphone with integrated multi-frequency transmitter**, with UHF PLL technology.

- Condenser microphone cartridge, cardioid polar pattern
- 2 frequency ranges
- SYNC function for synchronisation with receivers TXS-900 and TXS-920
- Mute function
- LCD for indicating channel and battery status
- Power supply via 2 x 1.5 V battery AA size (not supplied)

Model	TXS-900HT
Polar pattern	cardioid
System	condenser
Carrier frequency range	823-832 MHz + 863-865 MHz
Transmitting power	10 mW
Power supply	2 x 1.5 batt. AA size
Operating time	> 15 h
Audio frequency range	80-18,000 Hz
Dimensions	Ø 53 mm x 260 mm
Weight	220 g



### TXS-900HSE

Order No. 0255250

**Multifrequency pocket transmitter**, with UHF PLL technology.

- 2 frequency ranges
- SYNC function for synchronisation with receivers TXS-900 and TXS-920
- Mute function
- Sensitivity can be adjusted in 3 steps
- LCD for indicating channel and battery status
- Suitable for combination with headband/earband microphones and tie clip microphones with 3-pole mini XLR connector

Model	TXS-900HSE
Carrier frequency range	823-832 MHz + 863-865 MHz
Audio frequency range	80-18,000 Hz
Operating time	> 15 h
Admiss. ambient temp.	0-40 °C
Transmitting power	10 mW
Power supply transmitter	2 x 1.5 V batt. AA size
Dimensions transmitter	65 x 110 x 25 mm
Weight transmitter	76 g
Connections transmitter	1 x 3-pole mini XLR

- Belt clip
- Power supply via 2 x 1.5 V battery AA size (not supplied)



### TXS-900

Order No. 0255230

**Multifrequency receiver unit**, with UHF PLL technology.

- 2 licence-free frequency ranges
- 442 selectable channels
- Intermodulation-free presets, 4 groups with 8 channels each
- 12 intermodulation-free channels max. can be used in parallel (auto-scan)
- SYNC function for transmitting selected frequency to the transmitter
- True diversity system

Model	TXS-900
Carrier frequency range	823-832 MHz + 863-865 MHz
Audio frequency range	80-18,000 Hz
THD	< 1%
Dynamic range	> 100 dB
RF S/N ratio	> 100 dB
Admiss. ambient temp.	0-40 °C
Audio signal receiver	line: 75 mV, mic: 7 mV (jack, unbal.) line: 150 mV, mic: 15 mV (XLR, bal.)
Power supply receiver	via encl. plug-in power supply
Dimensions receiver	200 x 42 x 183 mm
Weight receiver	1.1 kg
Connections receiver	1 x XLR, bal., 1 x 6.3 mm jack, unbal.



### TXS-920

Order No. 0255240



**2-channel multifrequency receiver unit**, with UHF PLL technology.

- 2 licence-free frequency ranges
- 442 selectable channels
- Intermodulation-free presets, 4 groups with 8 channels each
- 12 intermodulation-free channels max. can be used in parallel (auto-scan)
- SYNC function for transmitting selected frequency to the transmitter
- True diversity system

Model	TXS-920
Carrier frequency range	823-832 MHz + 863-865 MHz
Audio frequency range	80-18,000 Hz
THD	< 1%
Dynamic range	> 100 dB
RF S/N ratio	> 100 dB
Admiss. ambient temp.	0-40 °C
Audio signal receiver	line: 75 mV, mic: 7 mV (jack, unbal.) line: 150 mV, mic: 15 mV (XLR, bal.) 75 mV (mix)
Power supply receiver	via encl. plug-in power supply
Dimensions receiver	420 x 42 x 183 mm
Weight receiver	2 kg
Connections receiver	2 x XLR, bal., 2 x 6.3 mm jack, unbal. 1 x 6.3 mm jack, unbal. (mix)



## TXS-1800HT

Order No. 0255150

**Hand-held microphone with integrated multi-frequency transmitter, 1.8 GHz**, with UHF PLL technology.

- Dynamic microphone cartridge, cardioid polar pattern
- Diecast aluminium body
- 192 selectable UHF frequencies (1,785-1,800 MHz) in 16 groups with 12 channels each, can be synchronised with receiver TXS-1800 via ADL function
- Adjustable sensitivity (0 dB, -3 dB, -6 dB)
- LCD for indicating frequency, gain setting and battery status

Model	TXS-1800HT
Polar pattern	cardioid
System	dynamic
Carrier frequency range	1,785-1,800 MHz
Transmitting power	10 mW
Power supply	2 x 1.5 V batt. AA size
Operating time	> 8 h
Audio frequency range	60-16,000 Hz
Dimensions	Ø 53 mm x 245 mm
Weight	350 g

- Transmitting power: 10 mW (EIRP)
- Mute function
- Power supply via 2 x 1.5 V battery AA size (not supplied)



## TXS-1800HSE

Order No. 0255140

**Multifrequency pocket transmitter, 1.8 GHz**, with UHF PLL technology.

- Suitable for combination with headband microphone or earband microphone with 3-pole mini XLR connector
- 192 selectable UHF frequencies (1,785-1,800 MHz) in 16 groups with 12 channels each, can be synchronised with receiver TXS-1800 via ADL function
- Adjustable sensitivity (0 dB, -3 dB, -6 dB)
- LCD for indicating frequency, gain setting and battery status

Model	TXS-1800HSE
Carrier frequency range	1,785-1,800 MHz
Audio frequency range	60-16,000 Hz
Operating time	> 8 h
Admiss. ambient temp.	0-40 °C
Transmitting power	10 mW
Power supply transmitter	2 x 1.5 V batt. AA size
Dimensions transmitter	64 x 102 x 28 mm
Weight transmitter	118 g
Connections transmitter	1 x 3-pole mini XLR

- Transmitting power: 10 mW (EIRP)
- Mute function
- Belt clip
- Power supply via 2 x 1.5 V battery AA size (not supplied)



## TXS-1800

Order No. 0255130

**Multifrequency receiver unit, 1.8 GHz**, with UHF PLL technology.

- 192 selectable UHF frequencies (1,785-1,800 MHz) in 16 groups with 12 channels each
- ADL function for transmitting selected parameters to the transmitter
- True diversity system with removable antennas (BNC connection)
- Auto-scan
- Pilot tone squelch, noise mute
- Autolock mode

Model	TXS-1800
Carrier frequency range	1,785-1,800 MHz
Audio frequency range	60-16,000 Hz
THD	< 0.8%
Dynamic range	> 95 dB
Admiss. ambient temp.	0-40 °C
Audio signal receiver	50 mV/1 kΩ (jack) 50 mV/150 Ω (XLR, bal.)
Power supply receiver	via encl. power supply
Dimensions receiver	212 x 47 x 175 mm
Weight receiver	1,300 g
Connections receiver	1 x XLR, bal., 1 x 6.3 mm jack unbal.



## TXS-1820

Order No. 0257700

**2-channel multifrequency receiver unit, 1.8 GHz**, with UHF PLL technology.

- 192 selectable UHF frequencies (1,785-1,800 MHz) in 16 groups with 12 channels each
- ADL function for transmitting selected parameters to the transmitter
- True diversity system with removable antennas (BNC connection)
- Auto-scan
- Pilot tone squelch, noise mute
- Autolock mode

Model	TXS-1820
Carrier frequency range	1,785-1,800 MHz
Audio frequency range	60-16,000 Hz
THD	< 0.8%
Dynamic range	> 95 dB
Admiss. ambient temp.	0-40 °C
Audio signal receiver	50 mV/1 kΩ (jack) 50 mV/150 Ω (XLR, bal.)
Power supply receiver	via encl. power supply
Dimensions receiver	410 x 47 x 175 mm
Weight receiver	2,100 g
Connections receiver	2 x XLR, 1 x XLR (mix), 1 x 6.3 mm jack (mix)



**There are restrictions or requirements in the EU!**

**Please read the notes on wireless systems in the section "IMPORTANT INFORMATION"!**

# Microphones

## Wireless Transmission

### TXS-707LT

Order No. 0257570

**Multifrequency tie clip microphone transmitter**, with UHF PLL technology.

- 100 selectable UHF frequencies (667.000-691.750 MHz)
- Continuously adjustable sensitivity
- Gain control
- Mute function
- LCD for indicating channel and battery status
- Operating range: 90 m (free field)

Model	TXS-707LT
Carrier frequency range	667.000-691.750 MHz
Audio frequency range	30-18,000 Hz
Operating time	> 15 h
Admiss. ambient temp.	0-40 °C
Transmitting power	10 mW
Power supply transmitter	2 x 1.5 V batt. AA size
Dimensions transmitter	62 x 105 x 26 mm
Weight transmitter	77 g
Connections transmitter	1 x 3.5 mm jack



### TXS-707HSE

Order No. 0257550

**Multifrequency pocket transmitter**, with UHF PLL technology.

- 100 selectable UHF frequencies (667.000-691.750 MHz)
- Continuously adjustable sensitivity
- Gain control
- Mute function
- LCD for indicating channel and battery status
- Operating range: 90 m (free field)

Model	TXS-707HSE
Carrier frequency range	667.000-691.750 MHz
Audio frequency range	30-18,000 Hz
Operating time	> 15 h
Admiss. ambient temp.	0-40 °C
Transmitting power	10 mW
Power supply transmitter	2 x 1.5 V batt. AA size
Dimensions transmitter	62 x 105 x 26 mm
Weight transmitter	77 g
Connections transmitter	1 x 3-pole mini XLR



### TXS-707

Order No. 0257540



**Multifrequency receiver unit**, with UHF PLL technology.

- 100 selectable UHF frequencies (667.000-691.750 MHz)
- SYNC function
- True diversity system with removable antennas
- Volume and squelch controls
- Pilot tone squelch

Model	TXS-707
Carrier frequency range	667.000-691.750 MHz
Audio frequency range	80-18,000 Hz
THD	< 0.5%
Dynamic range	100 dB
RF S/N ratio	105 dB
Admiss. ambient temp.	0-40 °C
Audio signal receiver	100 mV/600 Ω (jack) 20-30 mV/600 Ω (XLR, bal.)
Power supply receiver	via encl. plug-in power supply
Dimensions receiver	210 x 50 x 215 mm
Weight receiver	970 g
Connections receiver	1 x XLR, bal., 1 x 6.3 mm jack, unbal.



### TXS-727

Order No. 0257530



**2-channel multifrequency receiver unit**, with UHF PLL technology.

- 100 selectable UHF frequencies (667.000-691.750 MHz) for each channel
- SYNC function
- Volume and squelch controls adjustable for each channel
- Pilot tone squelch

Model	TXS-727
Carrier frequency range	667.000-691.750 MHz
Audio frequency range	80-18,000 Hz
THD	< 0.5%
Dynamic range	100 dB
RF S/N ratio	105 dB
Admiss. ambient temp.	0-40 °C
Audio signal receiver	100 mV/600 Ω (jack) 20-30 mV/600 Ω (XLR, bal.)
Power supply receiver	via encl. plug-in power supply
Dimensions receiver	482 x 50 x 255 mm
Weight receiver	1.65 kg
Connections receiver	2 x XLR, bal., 1 x 6.3 mm jack, unbal.





## TXS-865HT

Order No. 0255310

**Dynamic hand-held UHF PLL transmitter**, with REMOSET technology.

- Dynamic microphone cartridge, cardioid polar pattern
- 124 selectable channels in 6 channel groups (506-542 MHz)
- Adjustable sensitivity (12 dB to -18 dB)
- Backlit LCD for indicating channel and battery status
- Switchable transmitting power: 10 mW/50 mW (EIRP)
- Power supply via 2 x 1.5 V battery AA size (not supplied)
- Supplied with robust transport case and stand clamp

Model	TXS-865HT
Polar pattern	cardioid
System	dynamic
Carrier frequency range	506-542 MHz
Transmitting power	10 mW/50 mW, switchable
Power supply	2 x batt. AA size, alkaline
Operating time	> 25 h
Audio frequency range	50-16,000 Hz
Dimensions	Ø 50 mm x 250 mm
Weight	350 g



## TXS-865HSE

Order No. 0255300

**UHF PLL pocket transmitter**, with REMOSET technology.

- Suitable for combination with headband microphone or earband microphone with 3-pole mini XLR connector
- 124 selectable channels in 6 channel groups
- Adjustable sensitivity (12 dB to -18 dB)
- Selectable attenuation (0 dB/-6 dB/-20 dB)
- Lock function
- Backlit LCD for indicating channel and battery status

Model	TXS-865HSE
Carrier frequency range	506-542 MHz
Audio frequency range	40-18,000 Hz
Operating time	> 25 h
Admiss. ambient temp.	0-40 °C
Transmitting power	10 mW
Power supply transmitter	2 x batt. AA size, alkaline
Dimensions transmitter	68 x 172 x 21 mm
Weight transmitter	77 g
Connections transmitter	1 x 3-pole mini XLR



## TXS-855

Order No. 0255280

**Single-channel diversity UHF PLL receiver**, with REMOSET technology.

- 124 selectable channels in 6 channel groups
- Parallel operation of up to 20 channels
- Diversity system with removable antennas
- Integrated scan function
- Pilot tone squelch and noise squelch

Model	TXS-855
Carrier frequency range	506-542 MHz
Audio frequency range	40-18,000 Hz
THD	< 0.6%
Dynamic range	> 105 dB
Admiss. ambient temp.	0-40 °C
Audio signal receiver	100 mV XLR, 100 mV jack
Power supply receiver	via encl. power supply
Dimensions receiver	210 x 42 x 195 mm
Weight receiver	525 g
Connections receiver	1 x XLR, bal., 1 x 6.3 mm jack, bal.



## TXS-865

Order No. 0255290



**2-channel diversity UHF PLL receiver**, with REMOSET technology.

- 124 selectable channels in 6 channel groups (506-542 MHz)
- Parallel operation of up to 20 channels
- Diversity system with removable antennas (BNC connection)
- Integrated scan function
- Pilot tone squelch and noise squelch
- Attenuator with 2-way switching

Model	TXS-865
Carrier frequency range	506-542 MHz
Audio frequency range	40-18,000 Hz
THD	< 0.6%
Dynamic range	> 105 dB
Admiss. ambient temp.	0-40 °C
Audio signal receiver	100 mV XLR, 100 mV jack
Power supply receiver	via encl. power supply
Dimensions receiver	420 x 54 x 230 mm
Weight receiver	2 kg
Connections receiver	2 x XLR, bal., 1 x 6.3 mm jack, bal.



**There are restrictions or requirements in the EU!**

**Please read the notes on wireless systems in the section "IMPORTANT INFORMATION"!**

# Microphones

## Wireless Transmission

### TXS-871HT

Order No. 0253610

**Hand-held microphone with integrated multi-frequency transmitter**, with UHF PLL technology.

- Dynamic microphone cartridge, hypercardioid polar pattern
- Diecast aluminium body
- 15 selectable UHF frequencies (863-865 MHz)
- Adjustable sensitivity (0 dB, -10 dB, -20 dB, -30 dB)
- LCD for indicating frequency and battery status
- Transmitting power: < 10 mW (EIRP)
- Selectable lock mode
- Power supply via 2 x 1.5 V battery AA size (not supplied)
- Supplied with plastic case, microphone holder and 7 coloured caps to be pushed on

Model	TXS-871HT
Polar pattern	hypercardioid
System	dynamic
Carrier frequency range	863-865 MHz
Transmitting power	< 10 mW
Power supply	2 x 1.5 V batt. AA size
Operating time	> 30 h
Audio frequency range	50-16,000 Hz
Dimensions	Ø 50 mm x 260 mm
Weight	350 g

Replacement cartridge available:

MD-872: condenser cartridge with an even more brilliant sound, supercardioid polar pattern



**Licence-free in the EU.**

### TXS-871HSE

Order No. 0253620

**Multifrequency pocket transmitter**, with UHF PLL technology.

- Suitable for combination with headband microphone or earband microphone with 3-pole mini XLR connector
- 15 selectable UHF frequencies (863-865 MHz)
- Adjustable sensitivity
- LCD for indicating frequency and battery status
- Transmitting power: < 10 mW (EIRP)
- Selectable lock mode
- Power supply via 2 x 1.5 V battery AA size (not supplied)
- Supplied in a plastic case

Model	TXS-871HSE
Carrier frequency range	863-865 MHz
Audio frequency range	40-18,000 Hz
Operating time	> 30 h
Admiss. ambient temp.	0-40 °C
Transmitting power	< 10 mW
Power supply transmitter	2 x 1.5 V batt. AA size
Dimensions transmitter	78 x 190 x 34 mm
Weight transmitter	160 g
Connections transmitter	1 x 3-pole mini XLR

**Licence-free in the EU.**



### TXS-871

Order No. 0253600

**Multifrequency receiver unit**, with UHF PLL technology.

- 15 selectable UHF frequencies (863-865 MHz)
- True diversity system with removable antennas (BNC connection)
- Auto-scan
- Pilot tone squelch, noise mute
- Selectable lock mode
- LCD for indicating frequency, antenna A/B, RF receiving level, AF audio level, battery status of the transmitter
- XLR output and 6.3 mm output
- Supplied with power supply
- Supplies operating voltage to TXS-875B

Model	TXS-871
Carrier frequency range	863-865 MHz
Audio frequency range	40-18,000 Hz
THD	< 0.6%
Dynamic range	> 105 dB
Admiss. ambient temp.	0-40 °C
Audio signal receiver	900 mV/1 kΩ (jack) 150 mV/150 Ω (XLR, bal.)
Power supply receiver	via encl. power supply
Dimensions receiver	211 x 40 x 130 mm
Weight receiver	1.1 kg
Connections receiver	1 x XLR, bal., 1 x 6.3 mm jack, unbal.



**Licence-free in the EU.**

## TXS-875HT

Order No. 0255340

**Hand-held microphone with integrated multi-frequency transmitter**, with UHF PLL technology.

- Dynamic microphone cartridge, hypercardioid polar pattern
- Diecast aluminium body
- 193 selectable UHF frequencies (518-542 MHz)
- Adjustable sensitivity (0 dB, -10 dB, -20 dB, -30 dB)
- LCD for indicating frequency and battery status
- Transmitting power: 10 mW (EIRP)
- Selectable lock mode
- Power supply via 2 x 1.5 V battery AA size (not supplied)
- Supplied with plastic case, microphone holder and 7 coloured caps to be pushed on

Model	TXS-875HT
Polar pattern	hypercardioid
System	dynamic
Carrier frequency range	518-542 MHz
Transmitting power	10 mW
Power supply	2 x 1.5 batt. AA size
Operating time	> 30 h
Audio frequency range	50-16,000 Hz
Dimensions	Ø 50 mm x 260 mm
Weight	350 g

Replacement cartridge available:

MD-872: condenser cartridge with an even more brilliant sound, supercardioid polar pattern



## TXS-875HSE

Order No. 0255330

**Multifrequency pocket transmitter**, with UHF PLL technology.

- Suitable for combination with headband microphone or earband microphone with 3-pole mini XLR connector
- 193 selectable UHF frequencies (518-542 MHz)
- Adjustable sensitivity
- LCD for indicating frequency and battery status
- Transmitting power: 10 mW (EIRP)
- Selectable lock mode
- Power supply via 2 x 1.5 V battery AA size (not supplied)
- Supplied in a plastic case

Model	TXS-875HSE
Carrier frequency range	518-542 MHz
Audio frequency range	40-18,000 Hz
Operating time	> 30 h
Admiss. ambient temp.	0-40 °C
Transmitting power	10 mW
Power supply transmitter	2 x 1.5 V batt. AA size
Dimensions transmitter	78 x 190 x 34 mm
Weight transmitter	160 g
Connections transmitter	1 x 3-pole mini XLR



## TXS-875

Order No. 0255320

**Multifrequency receiver unit**, with UHF PLL technology.

- 193 selectable UHF frequencies (518-542 MHz)
- True diversity system with removable antennas (BNC connection)
- Auto-scan
- Pilot tone squelch, noise mute
- Selectable lock mode
- LCD for indicating frequency, antenna A/B, RF receiving level, AF audio level, battery status of the transmitter
- XLR output and 6,3 mm output
- Supplied with power supply
- Supplies operating voltage to TXS-875B

Model	TXS-875
Carrier frequency range	518-542 MHz
Audio frequency range	40-18,000 Hz
THD	< 0.6%
Dynamic range	> 105 dB
Admiss. ambient temp.	0-40 °C
Audio signal receiver	900 mV/1 kΩ (jack) 150 mV/150 Ω (XLR, bal.)
Power supply receiver	via encl. power supply
Dimensions receiver	211 x 40 x 130 mm
Weight receiver	1.1 kg
Connections receiver	1 x XLR, bal., 1 x 6,3 mm jack, unbal.



**There are restrictions or requirements in the EU!**

**Please read the notes on wireless systems in the section "IMPORTANT INFORMATION"!**

# Microphones

## Wireless Transmission

### TXS-891HSE

Order No. 0255390

**Multifrequency pocket transmitter**, with UHF PLL technology.

- Suitable for combination with headband microphone or earband microphone with 3-pole mini XLR connector
- 16 UHF channels (863-865 MHz), to be selected via rotary switch
- Transmitting power: 10 mW (EIRP)
- Power supply via 2 x 1.5 V battery AA size (not supplied)
- Supplied with artificial leather bag

**Licence-free in the EU.**

Model	TXS-891HSE
Carrier frequency range	863-865 MHz
Audio frequency range	40-18,000 Hz
Operating time	> 30 h
Admiss. ambient temp.	0-40 °C
Transmitting power	10 mW
Power supply transmitter	2 x 1.5 V batt. AA size
Dimensions transmitter	68 x 195 x 25 mm
Weight transmitter	130 g
Connections transmitter	1 x 3-pole mini XLR



### TXS-891HT

Order No. 0255400

**Hand-held microphone with integrated multifrequency transmitter**, with UHF PLL technology.

- Dynamic microphone cartridge, hypercardioid polar pattern
- Diecast aluminium body
- 16 selectable UHF channels (863-865 MHz)
- LCD for indicating channel and battery status
- Transmitting power: 10 mW (EIRP)
- Adjustable sensitivity (0 dB, -10 dB, -20 dB, -30 dB)
- Selectable lock mode
- Power supply via 2 x 1.5 V battery AA size (not supplied)
- Supplied with plastic case, microphone holder and 7 coloured caps to be pushed on

**Licence-free in the EU!**

Model	TXS-891HT
Polar pattern	hypercardioid
System	dynamic
Carrier frequency range	863-865 MHz
Transmitting power	< 10 mW
Power supply	2 x 1.5 V batt. AA size
Operating time	> 30 h
Audio frequency range	50-16,000 Hz
Dimensions	Ø 50 mm x 260 mm
Weight	350 g

Replacement cartridge available:

MD-872: condenser cartridge with an even more brilliant sound, supercardioid polar pattern



### TXS-891

Order No. 0255380



**2-channel multifrequency receiver unit**, with UHF PLL technology.

- Switching diversity system with removable antennas (BNC connection)
- 2 channels can be used simultaneously
- 16 selectable UHF frequencies for each channel (863-865 MHz)
- Pilot tone squelch and noise squelch
- Volume and squelch controls for each channel
- Selectable lock mode
- LCD for indicating channel, antenna A/B, RF receiving level and AF audio level
- XLR output for each channel, bal.
- 6.3 mm output for mixed signal
- Supplies operating voltage to TXS-875B

Model	TXS-891
Carrier frequency range	863-865 MHz
Audio frequency range	40-18,000 Hz
THD	< 0.6%
Dynamic range	> 105 dB
Admiss. ambient temp.	0-40 °C
Audio signal receiver	500 mW/1 kΩ (jack) 150 mV/150 Ω (XLR, bal.)
Power supply receiver	via encl. power supply
Dimensions receiver	420 x 55 x 230 mm
Weight receiver	2.1 kg
Connections receiver	2 x XLR, bal., 1 x 6.3 mm jack, unbal.

- Supplied with power supply
- 482 mm (19") rack installation possible with supplied mounting brackets

**Licence-free in the EU.**



## TXS-895HT

Order No. 0255370

**Hand-held microphone with integrated multi-frequency transmitter**, with UHF PLL technology.

- Dynamic microphone cartridge, hypercardioid polar pattern
- Diecast aluminium body
- 16 selectable UHF channels (518-542 MHz)
- LCD for indicating channel and battery status
- Transmitting power: 10 mW (EIRP)
- Adjustable sensitivity (0 dB, -10 dB, -20 dB, -30 dB)
- Selectable lock mode
- Supplied with plastic case, microphone holder and 7 coloured caps to be pushed on

Model	TXS-895HT
Polar pattern	hypercardioid
System	dynamic
Carrier frequency range	518-542 MHz
Transmitting power	10 mW
Power supply	2 x 1.5 batt. AA size
Operating time	> 30 h
Audio frequency range	50-16,000 Hz
Dimensions	Ø 50 mm x 260 mm
Weight	350 g

Replacement cartridge available:

MD-872: condenser cartridge with an even more brilliant sound, supercardioid polar pattern



## MD-872

Order No. 0233440

**Condenser microphone cartridge for TXS-872HT/TXS-871HT/TXS-875HT**

- Supercardioid polar pattern
- Ideally suited for vocals, especially for musicians and stage applications
- With extended frequency range, more precise bass frequencies and more brilliant high frequencies
- Frequency range: 50-18,000 Hz
- Impedance: 2.2 kΩ

Model	MD-872
Polar pattern	supercardioid
Frequency range	50-18,000 Hz
Sensitivity	7 mV/Pa
Output impedance	2.2 kΩ
S/N ratio	77 dB
Weight	92 g

- Sensitivity: 7 mV/Pa/1 kHz

- S/N ratio: 77 dB

**Suitable as a replacement cartridge for hand-held microphone transmitters TXS-891HT, TXS-892HT and TXS-895HT.**



## TXS-895HSE

Order No. 0255360

**Multifrequency pocket transmitter**, with UHF PLL technology.

- Suitable for combination with headband microphones or earband microphones with 3-pole mini XLR connector
- 16 UHF channels (518-542 MHz), adjustable via rotary switch
- Transmitting power: 10 mW (EIRP)
- Power supply via 2 x 1.5 V battery AA size (not supplied) Supplied with imitation leather bag

Model	TXS-895HSE
Carrier frequency range	518-542 MHz
Audio frequency range	40-18,000 Hz
Operating time	> 30 h
Admiss. ambient temp.	0-50 °C
Transmitting power	10 mW
Power supply transmitter	2 x 1.5 V batt. AA size
Dimensions transmitter	68 x 195 x 25 mm
Weight transmitter	130 g
Connections transmitter	1 x 3-pole mini XLR



## TXS-895

Order No. 0255350



**2-channel multifrequency receiver unit**, with UHF PLL technology.

- Switching diversity system with removable antennas (BNC connection)
- 2 channels can be used simultaneously
- 16 selectable UHF frequencies for each channel (518-542 MHz)
- Pilot tone squelch and noise squelch
- Volume and squelch controls for each channel
- Selectable lock mode
- LCD for indicating channel, antenna A/B, RF receiving level and AF audio level
- XLR output for each channel, bal.
- 6.3 mm output for mixed signal

Model	TXS-895
Carrier frequency range	518-542 MHz
Audio frequency range	40-18,000 Hz
THD	< 0.6%
Dynamic range	> 105 dB
Admiss. ambient temp.	0-40 °C
Audio signal receiver	500 mW/1 kΩ (jack) 150 mW/150 Ω (XLR, bal.)
Power supply receiver	via encl. power supply
Dimensions receiver	420 x 55 x 230 mm
Weight receiver	2.1 kg
Connections receiver	2 x XLR, bal., 1 x 6.3 mm jack, unbal.

- Supplies operating voltage to TXS-875B

- Supplied with power supply



**There are restrictions or requirements in the EU!**

**Please read the notes on wireless systems in the section "IMPORTANT INFORMATION"!**

# Microphones

## Wireless Transmission

### TXS-611SET

Order No. 0253650

**Multifrequency microphone system**, with UHF PLL technology.

- 1 hand-held microphone transmitter (cardioid polar pattern), 1 receiver, 1 plug-in power supply
- True diversity system
- 80 selectable UHF channels
- ACT function for transmitting selected frequency to the hand-held microphone via infrared signal

**Licence-free system in the EU.**

Model	TXS-611SET
Carrier frequency range	863-865 MHz
Audio frequency range	50-18,000 Hz
THD	< 0.5%
Dynamic range	120 dB
RF S/N ratio	105 dB
Admiss. ambient temp.	0-40 °C
Transmitting power	< 10 mW
Operating range	≈ 30 m
Power supply transmitter	2 x 1.5 V batt. AA size
Dimensions transmitter	Ø 52 mm x 275 mm
Weight transmitter	235 g
Audio signal receiver	350 mV/10 kΩ (jack) 25 mV/10 kΩ (XLR, bal.)
Power supply receiver	via encl. plug-in power supply
Dimensions receiver	152 x 38 x 120 mm
Weight receiver	482 g
Connections receiver	1 x 6.3 mm jack, unbal. 1 x XLR, bal.



### TXS-616SET

Order No. 0253490

**Multifrequency microphone system**, with UHF PLL technology.

- 1 hand-held microphone transmitter (cardioid polar pattern), 1 receiver, 1 plug-in power supply
- True diversity system
- 80 selectable UHF channels
- ACT function for transmitting the selected frequency to the hand-held microphone via infrared signal

Model	TXS-616SET
Carrier frequency range	672-692 MHz
Audio frequency range	50-18,000 Hz
THD	< 0.5%
Dynamic range	120 dB
RF S/N ratio	105 dB
Admiss. ambient temp.	0-40 °C
Transmitting power	< 25 mW/2.5 mW (EIRP)
Operating range	≈ 50 m
Power supply transmitter	2 x 1.5 V batt. AA size
Dimensions transmitter	Ø 52 mm x 275 mm
Weight transmitter	235 g
Audio signal receiver	350 mV/10 kΩ (jack) 25 mV/10 kΩ (XLR, bal.)
Power supply receiver	via encl. plug-in power supply
Dimensions receiver	152 x 38 x 120 mm
Weight receiver	482 g
Connections receiver	1 x 6.3 mm jack, unbal. 1 x XLR, bal.



### TXS-631SET

Order No. 0253660

**Multifrequency microphone system**, with UHF PLL technology.

- 1 pocket transmitter, 1 tie clip microphone, 1 receiver, 1 plug-in power supply
- True diversity system
- 80 selectable UHF channels
- ACT function for transmitting the selected frequency to the pocket transmitter via infrared signal

**Licence-free in the EU.**

Model	TXS-631SET
Carrier frequency range	863-865 MHz
Audio frequency range	50-18,000 Hz
THD	< 0.5%
Dynamic range	120 dB
RF S/N ratio	105 dB
Admiss. ambient temp.	0-40 °C
Transmitting power	< 10 mW
Operating range	≈ 30 m
Power supply transmitter	2 x 1.5 V batt. AA size
Dimensions transmitter	62 x 105 x 25 mm
Weight transmitter	88 g
Audio signal receiver	350 mV/10 kΩ (jack) 25 mV/10 kΩ (XLR, bal.)
Power supply receiver	via encl. plug-in power supply
Dimensions receiver	152 x 38 x 120 mm
Weight receiver	482 g
Connections receiver	1 x 6.3 mm jack, unbal. 1 x XLR, bal.



### TXS-636SET

Order No. 0253500

**Multifrequency microphone system**, with UHF PLL technology.

- 1 pocket transmitter, 1 tie clip microphone, 1 receiver, 1 plug-in power supply
- True diversity system
- 100 selectable UHF channels
- ACT function for transmitting the selected frequency to the hand-held microphone via infrared signal

Model	TXS-636SET
Carrier frequency range	672-692 MHz
Audio frequency range	50-18,000 Hz
THD	< 0.5%
Dynamic range	120 dB
RF S/N ratio	105 dB
Admiss. ambient temp.	0-40 °C
Transmitting power	< 10 mW
Operating range	≈ 30 m
Power supply transmitter	2 x 1.5 V batt. AA size
Dimensions transmitter	62 x 105 x 25 mm
Weight transmitter	88 g
Audio signal receiver	350 mV/10 kΩ (jack) 25 mV/10 kΩ (XLR, bal.)
Power supply receiver	via encl. plug-in power supply
Dimensions receiver	152 x 38 x 120 mm
Weight receiver	482 g
Connections receiver	1 x 6.3 mm jack, unbal. 1 x XLR, bal.





## TXS-2402SET

Order No. 0254090

### Digital wireless 2-channel PLL microphone system, 2.4 GHz

- 2 microphone transmitters, 1 receiver, 1 plug-in power supply
- High resistance to interference due to digital transmission
- 2 systems can be used in parallel
- 16 frequencies for each channel can be selected at the transmitter
- Wireless auto-configuration of the receiver
- Volume control for each channel
- 6.3 mm output for mixed signal

Licence-free in the EU.

Model	TXS-2402SET
Carrier frequency range	2,404-2,476 MHz
Audio frequency range	80-12,000 Hz
THD	< 0.1%
Dynamic range	87 dB
Admiss. ambient temp.	0-40 °C
Transmitting power	10 mW
Operating range	approx. 30 m (free field) approx. 20 m (indoors)
Power supply transmitter	2 x 1.5 V batt. AA size
Dimensions transmitter	Ø 54 mm x 225 mm
Weight transmitter	120 g
Audio signal receiver	100 mV/600 Ω
Power supply receiver	via encl. plug-in power supply
Dimensions receiver	220 x 45 x 150 mm
Weight receiver	550 g
Connections receiver	1 x 6.3 mm jack, unbal.



## TXS-2401SX

Order No. 0254680

### Digital wireless pocket transmitter, 2.4 GHz, matching the 2-channel PLL microphone system TXS-2402SET.

- High resistance to interference due to digital transmission
- 16 selectable frequencies (2,404-2,476 MHz)
- Volume control
- Power LED
- Belt clip
- Headband microphone and tie clip microphone, each with latchable 3.5 mm plug
- Power supply via 2 x 1.5 V battery AA size (not supplied)

Licence-free in the EU.

Model	TXS-2401SX
Carrier frequency range	2,404-2,476 MHz
Audio frequency range	80-12,000 Hz
Operating time	> 20 h
Admiss. ambient temp.	0-40 °C
Transmitting power	10 mW
Power supply transmitter	2 x 1.5 V batt. AA size
Dimensions transmitter	62 x 90 x 28 mm
Weight transmitter	105 g
Connections transmitter	1 x 3.5 mm jack



## TXS-812SET

Order No. 0252600



### Wireless 2-channel microphone system

- 2 microphone transmitters, 1 receiver, 1 plug-in power supply
- Two-channel UHF version (non-diversity) with channel mixing function which can additionally be selected
- Volume and squelch controls for each channel
- Each channel with LEDs for indicating RF signal and audio signal

Licence-free in the EU.

Model	TXS-812SET
Carrier frequency range	863.80 MHz, 864.20 MHz
Audio frequency range	40-15,000 Hz
THD	< 0.5%
Dynamic range	> 90 dB
RF S/N ratio	> 80 dB
Admiss. ambient temp.	0-40 °C
Transmitting power	< 10 mW
Operating range	approx. 30 m
Power supply transmitter	2 x 1.5 V batt. AA size (not supplied)
Dimensions transmitter	Ø 52 mm x 260 mm
Weight transmitter	240 g
Audio signal receiver	0-200 mV/10 kΩ (jack) 0-400 mV/10 kΩ (XLR, bal.)
Power supply receiver	via encl. plug-in power supply
Dimensions receiver	210 x 46 x 190 mm
Weight receiver	560 g
Connections receiver	2 x XLR, bal. 1 x 6.3 mm jack, unbal.



# Microphones

## Wireless Transmission

### TXS-875B

Order No. 0150840



**Pair of antenna amplifiers, 470-960 MHz**, as RF signal amplification for multifrequency receiver units with matching supply voltage at the antenna terminals.

- Power supply via the receiver units
- DC feed-through output for cascading up to 2 x TXS-875B max.
- Supplied with mounting brackets
- Ideal for mobile applications: mounting facility for microphone stand with 16 mm (5/8") thread



### TXS-35BNC

Order No. 0247760



**Mounting brackets**, for offset antenna mounting.

- For 482 mm (19") rack installation
- Aluminium, black lacquered
- Fixed BNC jack, 35 cm antenna cable with BNC plug



### TXS-70BNC

Order No. 0021490



**Adapter cable set**, for offset antenna mounting.

- 2 x 35 cm antenna cable with BNC plug
- 2 x BNC bushing



### TXS-100BNC

Order No. 0247770



**Mounting brackets**, for offset antenna mounting.

- Aluminium, black lacquered
- Fixed BNC jack, 100 cm antenna cable with BNC plug



## TXS-875DS

Order No. 0150850



**4-way antenna splitter**, for operating up to four multifrequency receiver units with removable antennas (BNC) in the respective frequency range with one pair of antennas.

With this device, it is no longer necessary to use respective antennas and plug-in power supplies of the individual devices. The power is supplied via four available low-voltage outputs. Supplied with matching connection cables. Each antenna connection via BNC jack.

- Frequency range: 470-960 MHz
- 2-way RF output for easily cascading several antenna splitters TXS-875DS
- Dimensions: 482 x 45 x 250 mm, 1 RS
- Weight: 2.2 kg
- Power supply: ~ 230 V/50 Hz/60 VA
- Low-voltage outputs for power supply of 4 x = 12 V/1 A max.
- Supplies operating voltage for TXS-875B



## TXS-85ANT

Order No. 0255270

**Replacement rod antenna**, particularly suitable for multifrequency receiver units TXS-875, TXS-895 and antenna amplifier TXS-875B.

- Perfect reception due to half-wave length tuning ( $\lambda/2$ )
- Folding 90°, with 45° locking
- Flexible, with insulating plastic sheathing



## TXS-82ANT

Order No. 0253180

**Replacement rod antenna**, particularly suitable for multifrequency receiver units TXS-872, TXS-892 and antenna amplifier TXS-875B.

- Perfect reception due to half-wave length tuning ( $\lambda/2$ )
- Folding 90°, with 45° locking
- Flexible, with insulating plastic sheathing



## TXS-81ANT

Order No. 0253730

**Replacement rod antenna**, for UHF frequency receiver unit TXS-871.

- Perfect reception due to half-wave length tuning ( $\lambda/2$ )
- Folding 90°, with 45° locking
- Flexible, with insulating plastic sheathing

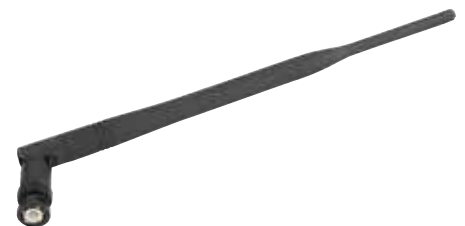

## TXS-1BNC

Order No. 0247750

**Replacement telescopic antenna**

- For VHF 175-225 MHz
- BNC connection



# Components

## Stage and Audio Accessories

### HSE-310/SK

Order No. 0234120

**Professional headband microphone**, with cardioid polar pattern and a high-quality sound which is suitable for any vocal or speech application. Innovative design features ensure a maximum suppression of both the impact sound and structure-borne noise as well as an extra low acoustic feedback, very comfortable to wear. Beige version.

- Corrosion-resistant neckband, easy to clean
- Drip ring (protects cartridge from moisture)
- Unobtrusive and secure fit due to cable routing in neck area incl. strain relief and cable bending protection
- Stable positioning

Model	HSE-310/SK
Polar pattern	cardioid
System	electret
Audio frequency range	50-18,000 Hz
Nominal impedance	2 k $\Omega$
Sensitivity	2.3 mV/Pa
Max. sound pressure	120 dB
Power supply	1.5-9 V
Weight	18 g (w/o cable and plug)
Connection	3-pole mini XLR

- Microphone windshield
- External power supply, e.g. via phantom power supply adapter EMA-1 or EMA-300P
- 3-pole mini XLR inline jack, matches EMA-1 or pocket transmitters TXS-...HSE



### HSE-200WP/BL

Order No. 0236370

**Electret headband microphone**, for fitness and aerobics.

- Splashproof
- Very comfortable to wear due to adjustable headband
- Secure fit even during strenuous applications, e.g. aerobics or spinning
- Back electret microphone cartridge with omnidirectional polar pattern
- Drip ring (additionally protects cartridge from moisture)
- Durable connection cable with textile sleeve

Model	HSE-200WP/BL
Polar pattern	omnidic.
System	back electret
Audio frequency range	20-20,000 Hz
Nominal impedance	2 k $\Omega$
Sensitivity	5.6 mV/Pa
Max. sound pressure	130 dB
Power supply	= 1.5-9 V
Weight	45 g
Connection	3-pole mini XLR

- 3-pole mini XLR inline jack for connection to an optional phantom power supply adapter (EMA-1, EMA-300P) or a pocket transmitter TXS-...HSE
- Rubber bushing for protecting the connector to be plugged into the pocket transmitter from moisture



### HSE-150A/SK

Order No. 0235160

**Ultra-light headband microphone**

- Omnidirectional polar pattern
- High-quality back electret cartridge
- Plug with latching device
- Supplied with adapters for the TXS-...HSE series (3-pole mini XLR) and pocket transmitters from JTS (4-pole mini XLR)
- Turning cartridge arm of adjustable length
- Drip ring (protects cartridge from moisture)
- Removable sweat-proof connection cable with 2.5 mm stereo plug (replacement connection cable: HSE-70C)

Model	HSE-150A/SK
Polar pattern	omnidic.
System	back electret
Audio frequency range	20-20,000 Hz
Nominal impedance	1 k $\Omega$
Sensitivity	8 mV/Pa
Max. sound pressure	130 dB
Power supply	= 1.5-9 V
Weight	7 g
Connection	2.5 mm stereo plug 2 connection adapters

- Optional adapters allow application with devices from other manufacturers
- External power supply e.g. via phantom power supply adapter EMA-1 or EMA-300P
- Microphone windshield



### HSE-140/SK

Order No. 0235530

**Ultra-light headband microphone**, for young artists.

- Small headband design, adjustable
- Omnidirectional polar pattern
- High-quality back electret cartridge
- 3-pole mini XLR connection
- Turning cartridge arm of adjustable length
- Drip ring (protects cartridge from moisture)
- Compatible with all TXS-...HSE pocket transmitters with 3-pole mini XLR connection

Model	HSE-140/SK
Polar pattern	omnidic.
System	back electret
Audio frequency range	20-20,000 Hz
Nominal impedance	1 k $\Omega$
Sensitivity	8 mV/Pa
Max. sound pressure	130 dB
Power supply	= 1.5-9 V
Weight	8 g
Connection	3-pole mini XLR

- External power supply e.g. via phantom power supply adapter EMA-1 or EMA-300P
- Microphone windshield



## HSE-152A/SK

Order No. 0235170

### Ultra-light headband microphone

- Cardioid polar pattern
- High-quality back electret cartridge
- Plug with latching device
- Supplied with adapters for the TXS-...HSE series (3-pole mini XLR) and pocket transmitters from JTS (4-pole mini XLR)
- Excellent feedback rejection
- Turning cartridge arm of adjustable length
- Drip ring (protects cartridge from moisture)
- Removable sweat-proof connection cable with 2.5 mm stereo plug (replacement connection cable: HSE-70C)

Model	HSE-152A/SK
Polar pattern	cardioid
System	back electret
Audio frequency range	20-20,000 Hz
Nominal impedance	1.5 k $\Omega$
Sensitivity	1.8 mV/Pa
Max. sound pressure	130 dB
Power supply	= 1.5-9 V
Weight	7 g
Connection	2.5 mm stereo plug 2 connecting adapters

- Optional adapters allow application with devices from other manufacturers
- External power supply e.g. via phantom power supply adapter EMA-1 or EMA-300P
- Microphone windshield



## HSE-110

Order No. 0232170

### Headband microphones

- High-quality back electret cartridge
- Very linear frequency response, especially resistant to external sound due to its supercardioid polar pattern with high back suppression
- The power supply adapter EMA-1 or a respective power supply is required for operation

HSE-100: with stripped cable ends

HSE-110: with 3-pole mini XLR inline jack, matching

EMA-1 or a pocket transmitter TXS-...HSE

HSE-120: with 3.5 mm plug

Model	HSE-110
Polar pattern	supercardioid
System	back electret
Audio frequency range	20-20,000 Hz
Nominal impedance	3 k $\Omega$
Sensitivity	7 mV/Pa
Max. sound pressure	120 dB
Power supply	= 1,3-20 V
Weight	69 g
Connection	3-pole mini XLR



## HSE-90

Order No. 0234070

### Electret headband microphone

This microphone is the right choice for applications which require an excellent sound as well as an extra low acoustic feedback and a secure fit.

- Cardioid polar pattern for high back suppression
- Integrated and external windshield/pop noise head minimise noise from wind, breath and articulation
- Flexible cartridge support for reducing low impact sound
- Wide transmission range
- Extra stable positioning

Model	HSE-90
Polar pattern	cardioid
System	back electret
Audio frequency range	20-20,000 Hz
Nominal impedance	650 $\Omega$
Sensitivity	10 mV/Pa
Max. sound pressure	120 dB
Power supply	= 1.5-9 V
Weight	25 g
Connection	3-pole mini XLR

- Movable gooseneck cartridge arm
- Temple rest
- Microphone windshield



## HSE-70A/SK

Order No. 0235190

### Hyperlight miniature earband microphone

- Unobtrusive design with earlobe support
- Omnidirectional polar pattern
- Premium high-quality back electret cartridge
- Supplied with adapters for the TXS-...HSE series (3-pole mini XLR) and pocket transmitters from JTS (4-pole mini XLR)
- Removable sweat-proof connection cable with 2.5 mm stereo plug (replacement connection cable: HSE-70C)
- Drip ring (protects cartridge from moisture)
- Optional adapters allow the application with devices from other manufacturers

Model	HSE-70A/SK
Polar pattern	omnidir.
System	back electret
Audio frequency range	20-20,000 Hz
Nominal impedance	2 k $\Omega$
Sensitivity	5.6 mV/Pa
S/N ratio	> 65 dB
Max. sound pressure	140 dB
Power supply	= 0.8-5 V
Weight	6 g
Connection	2.5 mm stereo plug 2 connecting adapters

- External power supply e.g. via phantom power supply adapter EMA-1 or EMA-300P
- Supplied with microphone windshield and bag



# Components

## Stage and Audio Accessories

### ECM-501L/SK

Order No. 0233900

#### Electret tie clip microphone

- Unobtrusive fit due to beige miniature design
- High-quality microphone cartridge with omnidirectional polar pattern
- Removable clip
- 1.2 m connection cable with 3-pole mini XLR

Model	ECM-501L/SK
Polar pattern	omnidir.
System	electret
Audio frequency range	20-20,000 Hz
Nominal impedance	1 k $\Omega$
Sensitivity	5.6 mV/Pa
Max. sound pressure	110 dB
Power supply	= 1.5-9 V
Dimensions	Ø 5 mm x 10 mm
Weight	5 g
Connection	3-pole mini XLR



### ECM-500L/SK

Order No. 0233890

#### Electret tie clip microphone

- Unobtrusive fit due to beige miniature design
- High-quality microphone cartridge with omnidirectional polar pattern
- Removable clip
- 1.2 m connection cable with 3.5 mm plug

Model	ECM-500L/SK
Polar pattern	omnidir.
System	electret
Audio frequency range	20-20,000 Hz
Nominal impedance	1 k $\Omega$
Sensitivity	5.6 mV/Pa
Max. sound pressure	110 dB
Power supply	= 1.5-9 V
Dimensions	Ø 5 mm x 10 mm
Weight	5 g
Connection	3.5 mm plug



### ECM-402L

Order No. 0233520

#### Electret tie clip microphone, miniature version.

- Removable clip and 1.2 m connection cable
- 3-pole mini XLR inline jack for connection to an optional phantom power supply adapter (EMA-300P) or a pocket transmitter TXS-...HSE

Model	ECM-402L
Polar pattern	cardioid
System	electret
Audio frequency range	70-15,000 Hz
Nominal impedance	1.5 k $\Omega$
Sensitivity	7 mV/Pa
Max. sound pressure	120 dB
Power supply	via power supply adapter
Dimensions	Ø 7 mm x 22 mm
Weight	4 g
Connection	3-pole mini XLR



### ECM-300L

Order No. 0232400

#### Electret lavalier microphone

- Extra compact version
- Phantom power via optional adapter EMA-300P
- With 6 m connection cable and tie clip

Model	ECM-300L
Polar pattern	omnidir.
System	electret
Audio frequency range	50-18,000 Hz
Nominal impedance	400 $\Omega$
Sensitivity	4 mV/Pa
Max. sound pressure	120 dB
Power supply	via power supply adapter
Dimensions	Ø 9 mm x 21 mm
Weight	4 g
Connection	3-pole mini XLR, unbal.



### ECM-3003

Order No. 0230340

#### Electret tie clip microphone

- Excellent sound quality
- Microphone cartridge with omnidirectional polar pattern
- Strong clip
- Power supply in the 3.5 mm plug
- 4 m connection cable
- Supplied w/o button cell battery LR-44

Model	ECM-3003
Polar pattern	omnidir.
System	electret
Audio frequency range	50-16,000 Hz
Nominal impedance	1 k $\Omega$
Sensitivity	5.6 mV/Pa
S/N ratio	> 40 dB
Max. sound pressure	120 dB
Power supply	button cell 1.5 V (LR-44)
Dimensions	Ø 12 mm x 23 mm
Weight	70 g
Connection	3.5 mm plug



### ECM-821LT

Order No. 0235450

#### Electret tie clip microphone

- Microphone cartridge with cardioid polar pattern
- Removable clip
- 0.8 m connection cable with 3.5 mm plug, with latching device
- Microphone windshield

Model	ECM-821LT
Polar pattern	cardioid
System	electret
Audio frequency range	50-16,000 Hz
Nominal impedance	680 $\Omega$
Sensitivity	5.6 mV/Pa
Max. sound pressure	110 dB
Power supply	1.5-3 V
Dimensions	Ø 12 mm x 18 mm
Weight	20 g
Connection	3.5 mm plug





Now available!

**MONACOR**  
INTERNATIONAL  
THE AUDIO COMPANY



# INSTALLATION

EDITION 1

# Mixers

## Digital Mixers



### DELTA-160

Order No. 0203190



#### 16-channel digital audio mixer

- 12 mono input channels (comb. inputs XLR/6.3 mm jack)
- 2 stereo input channels
- 1 S/PDIF input
- 1 USB audio channel
- USB recording (stereo master) and playback with 192 kHz/24 bits max.
- Integrated DSP (2 x reverb, 2 x modulation, 2 x delay, 2 x 31-band graphic equalizer)
- 8 XLR outputs
- 1 monitor output (6.3 mm jack)
- 1 AES/EBU output
- 1 S/PDIF output
- Can be remote-controlled via app (iOS)
- +48 V phantom power, can be activated as required for each mono input channel

Model	DELTA-160
Mic input	0,4 mV/3 mV, bal. (comb. jack)
Line input	8 mV, bal. (stereo)
Master output	700 mV, bal. (XLR)
Monitor output	700 mV, bal. (6.3 mm jack)
Headphones	> 8 Ω
Frequency range	20-20,000 Hz
THD	< 0.01%
Crosstalk	> 69 dB
Equalizer bass	DSP (4-band equalizer)
Equalizer midrange	DSP (4-band equalizer)
Equalizer treble	DSP (4-band equalizer)
Power supply	via encl. power supply
Dimensions	335 x 140 x 410 mm
Weight	5.55 kg

- 1 adjustable headphone output
- 17.8 cm (7") colour LCD touch screen for display and settings
- Supplied with power supply



### RM/DELTA-160

Order No. 0203230

#### 482 mm mounting bracket set

- For rack installation of 16-channel digital audio mixer DELTA-160
- 2 mounting brackets
- Black lacquered metal version





## DELTA-160R

Order No. 0203180



### 16-channel digital audio mixer

- 12 mono input channels (8 XLR inputs, 4 comb. inputs XLR/6.3 mm jack)
- 2 stereo input channels
- 1 S/PDIF input
- 1 USB audio channel
- USB recording (stereo master) and playback with 192 kHz/24 bits max.
- Integrated DSP (2 x reverb, 2 x modulation, 2 x delay, 2 x 31-band graphic equalizer)
- 8 XLR outputs
- 1 AES/EBU output
- 1 S/PDIF output
- Can be remote-controlled via app (iOS)
- +48 V phantom power, can be activated as required for each mono input channel
- 1 adjustable headphone output
- 17.8 cm (7") colour LCD touch screen for display and settings
- 482 mm (19") rack installation, 4 RS

Model	DELTA-160R
Mic input	0,4 mV, bal. (XLR), 0,4 mV/3 mV, bal. (comb. jack)
Line input	8 mV, bal. (stereo)
Master output	700 mV, bal. (XLR)
Headphones	> 8 Ω
Frequency range	20-20,000 Hz
THD	< 0,01%
Crosstalk	> 69 dB
Equalizer bass	DSP (4-band equalizer)
Equalizer midrange	DSP (4-band equalizer)
Equalizer treble	DSP (4-band equalizer)
Power supply	~ 100-240 V/50-60 Hz/45 VA
Dimensions	482 x 180 x 155 mm
Weight	4,62 kg

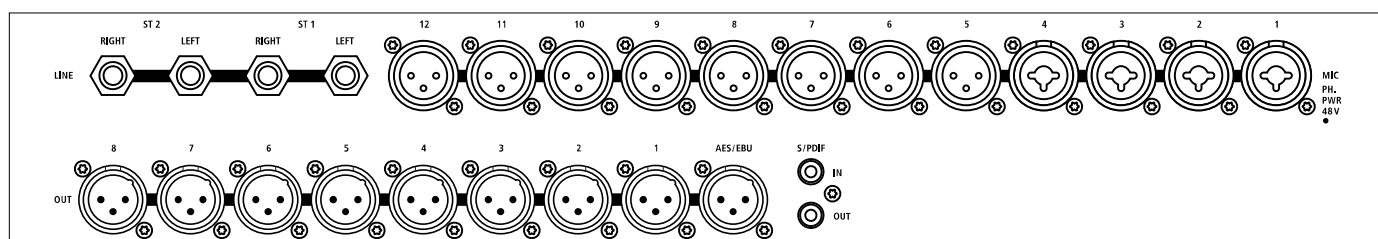





## DMIX-20/2

Order No. 0203200



**20-channel digital audio mixer**, with touch screen, 2 DSP effect units and USB interface.

- 16 mono input channels with assignable controls
- 8 channel inserts
- 2 stereo input channels
- 1 USB audio channel
- Full duplex USB port (allows for simultaneous recording and reproduction) for reproduction of digital audio data from a PC and for recording mixings onto a PC
- 2 integrated DSPs as well as equalizer, noise gate, compressor/limiter and delay

- 4 aux send outputs and 4 subgroup outputs or 8 aux outputs
- 6 DCA groups
- Control room function
- 100 mm motor-driven fader
- Sampling rate: 24 bits/48 kHz
- Settings can be stored
- Remote control possible via iPad (when connected to external router)
- RJ45 network connection for remote control
- +48 V phantom power
- 2 adjustable headphone outputs

- 17.8 cm colour LCD touch screen (7") for display and settings
- Mounting facility for extension modules available at option
- 482 mm (19") rack installation, 8 RS, with supplied mounting brackets

Model	DMIX-20/2
Mic input	3 mV, bal. (combo jack)
Line input	750 mV, bal. (stereo), 100 mV (mono),
Insert input	800 mV
Master output	750 mV, bal. (XLR) 750 mV (jack)
Aux output	8 V
Insert output	800 mV
Control room	2.3 V
Headphones	> 8 Ω
Frequency range	20-20,000 Hz
THD	< 0.01%
S/N ratio	> 104 dB
Crosstalk	> 80 dB
Equalizer bass	±24 dB/21-19,200 Hz (dep. on filter)
Equalizer midrange	±24 dB/21-19,200 Hz (dep. on filter) ±24 dB/21-19,200 Hz (dep. on filter)
Equalizer treble	±24 dB/21-19,200 Hz (dep. on filter)
Power supply	~ 230 V/50 Hz/60 VA
Dimensions	442 x 355 x 130 mm
Weight	7.3 kg



## DMIX-20IO/2

Order No. 0203220

**32-channel input/output module**, for digital mixer DMIX-20/2.

- Digital audio interface for recording audio data
- Recording and reproduction of 32 channels via the PC (32 input channels, 32 output channels)
- Sampling rate: 48 kHz/24 bits
- Mini PCI plug-in board
- Connections: USB Type-B jack (USB 2.0, 380 Mbps)



## DMIX-20DTM/2

Order No. 0203210

**Module**, for inserting digital mixer DMIX-20/2 into a Dante® network.

- Audio transmission via Ethernet using Dante® protocol
- Parallel transmission of 32 x 32 audio channels
- Easy signal control via network technology
- Mini PCI plug-in board
- Connections: 2 x RJ45

System requirements: Windows\* 7/8/10 or MacOS X

The brand Dante® as well as the Dante® software which may have been integrated into these products are licenced by Audinate Pty Ltd.



## DMIX-20WIFI

Order No. 0202920



**Module**, for remote control of digital mixer DMIX-20 and DMIX-20/2 with app for iPads without external router.

- Portable WLAN router for wireless signal transmission
- Free app available from Apple App Store
- Integrated Wi-Fi antenna (2.4 GHz)
- Connections: USB Type-B jack



## MR-DMIX20

Order No. 0257720

**Flight case**, for transporting one digital audio mixer DMIX-20.

- Multilayer multiplex wood, black laminated
- Aluminium profile edges
- Chromium-plated ball protection corners, reinforcing angles
- Butterfly locks, recessed drop handles
- Dimensions: 505 x 230 x 495 mm
- Weight: 8.4 kg

Supplied w/o devices.



# Mixers

## Analogue Mixers

### MXR-120PRO

Order No. 0200620



**Professional 12-channel audio mixer**, with DSP effect unit, integrated MP3 player and Bluetooth receiver.

- Integrated USB audio interface (will be identified and addressed as an external sound card)
- Full-duplex USB port (allows for simultaneous recording and reproduction) for reproduction of digital audio data from a PC and for recording mixings onto a PC
- 8 mono input channels with gain control, 3-way equalizer and pan pot
- 2 stereo input channels with 3-way equalizer and balance control
- MP3 player
- USB interface
- Bluetooth receiver
- 16 different DSP effects
- Adjustable aux return input and FX send output
- +48 V phantom power, can be activated as required
- Adjustable headphone output
- Stereo LED level display



Model	MXR-120PRO
Mic input	0.6 mV, bal. 8 x XLR
Line input	80 mV (stereo), 2 x 6.3 mm jack L/R 7 mV (mono), 8 x 6.3 mm jack
Aux input	340 mV, 1 x 6.3 mm jack L/R
Master output	760 mV, 1 x 6.3 mm jack L/R
Effect send	9 V, 1 x 6.3 mm jack
Headphones	≥ 8 Ω, 1 x 6.3 mm jack
Frequency range	20-20,000 Hz
THD	< 0.03%
S/N ratio	> 75 dBA
Equalizer bass	±15 dB/80 Hz
Equalizer midrange	±15 dB/2.5 kHz
Equalizer treble	±15 dB/12 kHz
Power supply	~ 230 V/50 Hz/30 VA
Dimensions	484 x 93 x 320 mm
Weight	4.4 kg

### MXR-80PRO

Order No. 0200530



**Professional 8-channel audio mixer**, with DSP effect unit, integrated MP3 player and Bluetooth receiver.

- Integrated USB audio interface (will be identified and addressed as an external sound card)
- Full-duplex USB port (allows for simultaneous recording and reproduction) for reproduction of digital audio data from a PC and for recording mixings onto a PC
- 4 mono input channels with gain control, 3-way equalizer and pan pot
- 2 stereo input channels with 3-way equalizer and balance control
- MP3 player
- USB interface
- Bluetooth receiver
- 16 different DSP effects
- Adjustable aux return input and FX send output
- +48 V phantom power, can be activated as required
- Adjustable headphone output
- Stereo LED level display



Model	MXR-80PRO
Mic input	0.6 mV, bal. 4 x XLR
Line input	80 mV (stereo), 2 x 6.3 mm jack L/R 7 mV (mono), 4 x 6.3 mm jack
Aux input	340 mV, 1 x 6.3 mm jack L/R
Master output	760 mV, 1 x 6.3 mm jack L/R
Effect send	9 V, 1 x 6.3 mm jack
Headphones	≥ 8 Ω, 1 x 6.3 mm jack
Frequency range	20-20,000 Hz
THD	< 0.03%
S/N ratio	> 75 dBA
Equalizer bass	±15 dB/80 Hz
Equalizer midrange	±15 dB/2.5 kHz
Equalizer treble	±15 dB/12 kHz
Power supply	~ 230 V/50 Hz/25 VA
Dimensions	364 x 93 x 320 mm
Weight	3.4 kg



### MXR-60PRO

Order No. 0200500



**Professional 6-channel audio mixer**, with DSP effect unit, integrated MP3 player and Bluetooth receiver.

- Integrated USB audio interface (will be identified and addressed as an external sound card)
- Full-duplex USB port (allows for simultaneous recording and reproduction) for reproduction of digital audio data from a PC and for recording mixings onto a PC
- 4 mono input channels with gain control, 3-way equalizer and pan pot
- 1 stereo input channel with 3-way equalizer and balance control
- MP3 player
- USB interface
- Bluetooth receiver
- 16 different DSP effects
- Adjustable aux return input and FX send output
- +48 V phantom power, can be activated as required
- Adjustable headphone output
- Stereo LED level display



Model	MXR-60PRO
Mic input	0.6 mV, bal. 4 x XLR
Line input	80 mV (stereo), 2 x 6.3 mm jack L/R 7 mV (mono), 4 x 6.3 mm jack
Aux input	340 mV, 1 x 6.3 mm jack L/R
Master output	760 mV, 1 x 6.3 mm jack L/R
Effect send	9 V, 1 x 6.3 mm jack
Headphones	$\geq 8 \Omega$ , 1 x 6.3 mm jack
Frequency range	20-20,000 Hz
THD	< 0.03%
S/N ratio	> 75 dBA
Equalizer bass	$\pm 15$ dB/80 Hz
Equalizer midrange	$\pm 15$ dB/2.5 kHz
Equalizer treble	$\pm 15$ dB/12 kHz
Power supply	~ 230 V/50 Hz/20 VA
Dimensions	334 x 93 x 320 mm
Weight	3.2 kg

### MXR-40PRO

Order No. 0200490



**Professional 4-channel audio mixer**, with DSP effect unit, integrated MP3 player and Bluetooth receiver.

- Integrated USB audio interface (will be identified and addressed as an external sound card)
- Full-duplex USB port (allows for simultaneous recording and reproduction) for reproduction of digital audio data from a PC and for recording mixings onto a PC
- 2 mono input channels with gain control, 3-way equalizer and pan pot
- 1 stereo input channel with 3-way equalizer and balance control
- MP3 player
- USB interface
- Bluetooth receiver
- 16 different DSP effects
- Adjustable aux return input and FX send output
- +48 V phantom power, can be activated as required
- Adjustable headphone output
- Stereo LED level display



Model	MXR-40PRO
Mic input	0.6 mV, bal. 2 x XLR
Line input	80 mV (stereo), 1 x 6.3 mm jack L/R 7 mV (mono), 2 x 6.3 mm jack
Aux input	340 mV, 1 x 6.3 mm jack L/R
Master output	760 mV, 1 x 6.3 mm jack L/R
Effect send	9 V, 1 x 6.3 mm jack
Headphones	$\geq 8 \Omega$ , 1 x 6.3 mm jack
Frequency range	20-20,000 Hz
THD	< 0.03%
S/N ratio	> 75 dBA
Equalizer bass	$\pm 15$ dB/80 Hz
Equalizer midrange	$\pm 15$ dB/2.5 kHz
Equalizer treble	$\pm 15$ dB/12 kHz
Power supply	~ 230 V/50 Hz/15 VA
Dimensions	282 x 93 x 320 mm
Weight	2.7 kg

# Mixers

## Analogue Mixers

### MXR-160

Order No. 0200150



**16-channel audio mixer**, with integrated MP3 player and Bluetooth receiver.

- Integrated USB audio interface (will be identified and addressed as an external sound card)
- Full-duplex USB port (allows for simultaneous recording and reproduction) for reproduction of digital audio data from a PC and for recording mixings onto a PC
- 14 mono input channels with gain control, 3-way equalizer and pan pot
- 1 stereo input channel with 3-way equalizer and balance control
- MP3 player
- USB interface
- Bluetooth receiver
- DSP delay, adjustable
- Adjustable aux return input and FX send output
- Tape record/play connections
- 5-band stereo graphic equalizer
- +48 V phantom power, can be activated as required
- Pre-fader listening (PFL) to the stereo input channels via adjustable headphone output
- Stereo LED level display



Model	MXR-160
Mic input	2.2 mV, bal. 14 x XLR
Line input	50 mV (stereo), 1 x 6.3 mm jack L/R 30 mV (mono), 14 x 6.3 mm jack
Tape (play)	290 mV, 1 x RCA L/R
Aux input	420 mV, 1 x 6.3 mm jack L/R
Master output	880 mV, bal. 1 x XLR L/R 880 mV, 1 x 6.3 mm jack L/R
Effect send	9 V, 1 x 6.3 mm jack
Tape (rec)	400 mV, 1 x RCA L/R
Headphones	≥ 8 Ω, 1 x 6.3 mm jack
Frequency range	20-20,000 Hz
THD	< 0.03%
S/N ratio	> 82 dBA
Equalizer bass	±15 dB/80 Hz
Equalizer midrange	±15 dB/2.5 kHz
Equalizer treble	±15 dB/12 kHz
Power supply	~ 230 V/50 Hz/35 VA
Dimensions	614 x 53 x 340 mm
Weight	5.4 kg

### MXR-120

Order No. 0200100



**12-channel audio mixer**, with integrated MP3 player and Bluetooth receiver.

- Integrated USB audio interface (will be identified and addressed as an external sound card)
- Full-duplex USB port (allows for simultaneous recording and reproduction) for reproduction of digital audio data from a PC and for recording mixings onto a PC
- 10 mono input channels with gain control, 3-way equalizer and pan pot
- 1 stereo input channel with 3-way equalizer and balance control
- MP3 player
- USB interface
- Bluetooth receiver
- DSP delay, adjustable
- Adjustable aux return input and FX send output
- Tape record/play connections
- 5-band stereo graphic equalizer
- +48 V phantom power, can be activated as required
- Pre-fader listening (PFL) to the stereo input channels via adjustable headphone output
- Stereo LED level display



Model	MXR-120
Mic input	2.2 mV, bal. 10 x XLR
Line input	50 mV (stereo), 1 x 6.3 mm jack L/R 30 mV (mono), 10 x 6.3 mm jack
Tape (play)	290 mV, 1 x RCA L/R
Aux input	420 mV, 1 x 6.3 mm jack L/R
Master output	880 mV, bal. 1 x XLR L/R 880 mV, 1 x 6.3 mm jack L/R
Effect send	9 V, 1 x 6.3 mm jack
Tape (rec)	400 mV, 1 x RCA L/R
Headphones	≥ 8 Ω, 1 x 6.3 mm jack
Frequency range	20-20,000 Hz
THD	< 0.03%
S/N ratio	> 82 dBA
Equalizer bass	±15 dB/80 Hz
Equalizer midrange	±15 dB/2.5 kHz
Equalizer treble	±15 dB/12 kHz
Power supply	~ 230 V/50 Hz/30 VA
Dimensions	498 x 53 x 340 mm
Weight	4.4 kg

### MXR-80

Order No. 0200080



**8-channel audio mixer**, with integrated MP3 player and Bluetooth receiver.

- Integrated USB audio interface (will be identified and addressed as an external sound card)
- Full-duplex USB port (allows for simultaneous recording and reproduction) for reproduction of digital audio data from a PC and for recording mixings onto a PC
- 6 mono input channels with gain control, 3-way equalizer and pan pot
- 1 stereo input channel with 3-way equalizer and balance control
- MP3 player
- USB interface
- Bluetooth receiver
- DSP delay, adjustable
- Adjustable aux return input and FX send output
- Tape record/play connections
- 5-band stereo graphic equalizer
- +48 V phantom power, can be activated as required
- Pre-fader listening (PFL) to the stereo input channels via adjustable headphone output
- Stereo LED level display



Model	MXR-80
Mic input	2.2 mV, bal. 8 x XLR
Line input	50 mV (stereo), 1 x 6.3 mm jack L/R 30 mV (mono), 8 x 6.3 mm jack
Tape (play)	290 mV, 1 x RCA L/R
Aux input	420 mV, 1 x 6.3 mm jack L/R
Master output	880 mV, bal. 1 x XLR L/R 880 mV, 1 x 6.3 mm jack L/R
Effect send	9 V, 1 x 6.3 mm jack
Tape (rec)	400 mV, 1 x RCA L/R
Headphones	≥ 8 Ω, 1 x 6.3 mm jack
Frequency range	20-20,000 Hz
THD	< 0.03%
S/N ratio	> 82 dBA
Equalizer bass	±15 dB/80 Hz
Equalizer midrange	±15 dB/2.5 kHz
Equalizer treble	±15 dB/12 kHz
Power supply	~ 230 V/50 Hz/25 VA
Dimensions	382 x 53 x 340 mm
Weight	3.4 kg

### MXR-60

Order No. 0200630



**6-channel audio mixer**, with integrated MP3 player and Bluetooth receiver.

- Integrated USB audio interface (will be identified and addressed as an external sound card)
- Full-duplex USB port (allows for simultaneous recording and reproduction) for reproduction of digital audio data from a PC and for recording mixings onto a PC
- 4 mono input channels with gain control, 3-way equalizer and pan pot
- 1 stereo input channel with 3-way equalizer and balance control
- MP3 player
- USB interface
- Bluetooth receiver
- DSP delay, adjustable
- Adjustable aux return input and FX send output
- Tape record/play connections
- 5-band stereo graphic equalizer
- +48 V phantom power, can be activated as required
- Pre-fader listening (PFL) to the stereo input channels via adjustable headphone output
- Stereo LED level display



Model	MXR-60
Mic input	2.2 mV, bal. 4 x XLR
Line input	50 mV (stereo), 1 x 6.3 mm jack L/R 30 mV (mono), 4 x 6.3 mm jack
Tape (play)	290 mV, 1 x RCA L/R
Aux input	420 mV, 1 x 6.3 mm jack L/R
Master output	880 mV, bal. 1 x XLR L/R 880 mV, 1 x 6.3 mm jack L/R
Effect send	9 V, 1 x 6.3 mm jack
Tape (rec)	400 mV, 1 x RCA L/R
Headphones	≥ 8 Ω, 1 x 6.3 mm jack
Frequency range	20-20,000 Hz
THD	< 0.03%
S/N ratio	> 82 dBA
Equalizer bass	±15 dB/80 Hz
Equalizer midrange	±15 dB/2.5 kHz
Equalizer treble	±15 dB/12 kHz
Power supply	~ 230 V/50 Hz/20 VA
Dimensions	324 x 53 x 340 mm
Weight	2.9 kg

# Mixers

## Analogue Mixers

### MXR-6

Order No. 0200280



**6-channel audio mixer**, with DSP effect unit, integrated MP3 player and Bluetooth receiver.

- Integrated USB audio interface (will be identified and addressed as an external sound card)
- Full-duplex USB port (allows for simultaneous recording and reproduction) for reproduction of digital audio data from a PC and for recording mixings onto a PC
- 4 mono input channels with gain control, 2-way equalizer and pan pot
- 2 stereo input channels with 2-way equalizer and balance control
- MP3 player
- USB interface
- Bluetooth receiver
- 16 different DSP effects
- Adjustable aux return input and FX send output
- +48 V phantom power, can be activated as required
- Adjustable headphone output
- Stereo LED level display
- Power is provided via USB or enclosed power supply



Model	MXR-6
Mic input	2 mV, bal. 4 x XLR
Line input	100 mV (stereo), 2 x 6.3 mm jack L/R 60 mV (mono), 2 x 6.3 mm jack
Aux input	400 mV, 1 x 6.3 mm jack L/R
Master output	500 mV, 1 x 6.3 mm jack L/R
Effect send	4.4 V, 1 x 6.3 mm jack
Headphones	≥ 8 Ω, 1 x 6.3 mm jack
Frequency range	20-20,000 Hz
THD	< 0.03%
S/N ratio	> 83 dBA
Equalizer bass	±15 dB/80 Hz
Equalizer treble	±15 dB/12 kHz
Power supply	USB or encl. power supply
Dimensions	308 x 53 x 205 mm
Weight	1.9 kg

### MXR-4

Order No. 0200250



**4-channel audio mixer**, with DSP effect unit, integrated MP3 player and Bluetooth receiver.

- Integrated USB audio interface (will be identified and addressed as an external sound card)
- Full-duplex USB port (allows for simultaneous recording and reproduction) for reproduction of digital audio data from a PC and for recording mixings onto a PC
- 2 mono input channels with gain control, 2-way equalizer and pan pot
- 1 stereo input channel with 2-way equalizer and balance control
- MP3 player
- USB interface
- Bluetooth receiver
- 16 different DSP effects
- Adjustable aux return input and FX send output
- +48 V phantom power, can be activated as required
- Adjustable headphone output
- Stereo LED level display
- Power is provided via USB or supplied power supply



Model	MXR-4
Mic input	2 mV, bal. 2 x XLR
Line input	100 mV (stereo), 2 x 6.3 mm jack L/R 60 mV (mono), 2 x 6.3 mm jack
Aux input	400 mV, 1 x 6.3 mm jack L/R
Master output	500 mV, 1 x 6.3 mm jack L/R
Effect send	4.4 V, 1 x 6.3 mm jack
Headphones	≥ 8 Ω, 1 x 6.3 mm jack
Frequency range	20-20,000 Hz
THD	< 0.03%
S/N ratio	> 83 dBA
Equalizer bass	±15 dB/80 Hz
Equalizer treble	±15 dB/12 kHz
Power supply	USB or encl. power supply
Dimensions	228 x 53 x 205 mm
Weight	1.4 kg

### MPX-30DMP

Order No. 0202760

#### Stereo DJ mixer with integrated MP3 player

Mixer:

- 3 input channels (5 stereo ways, 1 DJ microphone way)
- Input channels, each with gain control, 3-way equalizer and cue button, with LED level display of the stereo master
- Talkover function
- Adjustable headphone output with pre-fader listening to the stereo input channels and the master output
- Crossfader with switchable characteristic and reverse switch
- Master output with stereo LED level display
- Additional outputs booth and record

MP3 player with USB interface and SD/MMC card slot:

- USB storage media can be connected directly (e.g. USB flash drive)
- For SD/MMC cards up to 32 GB (FAT 6/FAT 32), available at option
- Alphanumeric display
- Repeat function
- Blue backlit display

Model	MPX-30DMP
Mic input	1 mV, 1 x 3-pole XLR/6.3 mm jack
Line input	70 mV (line 1), 1 x RCA L/R 50 mV (line 2-3), 2 x RCA L/R
Phono input	2 mV (phono 1), 1 x RCA L/R 1 mV (phono 2-3), 2 x RCA L/R
Master output	1 V, 1 x 3-pole XLR L/R, bal. 580 mV, 1 x RCA L/R
Record output	200 mV, 1 x RCA L/R
Booth output	500 mV, 1 x RCA L/R
Headphones	≥ 8 Ω, stereo
Frequency range	20-20,000 Hz
THD	< 0.15%
S/N ratio	> 60 dB, unweighted
Equalizer bass	+12 dB, -32 dB/50 Hz
Equalizer midrange	+12 dB, -32 dB/1.2 kHz
Equalizer treble	+12 dB, -32 dB/10 kHz
Talkover	-16 dB
Power supply	~ 230 V/50 Hz/20 VA
Dimensions	245 x 315 x 120 mm
Weight	3 kg

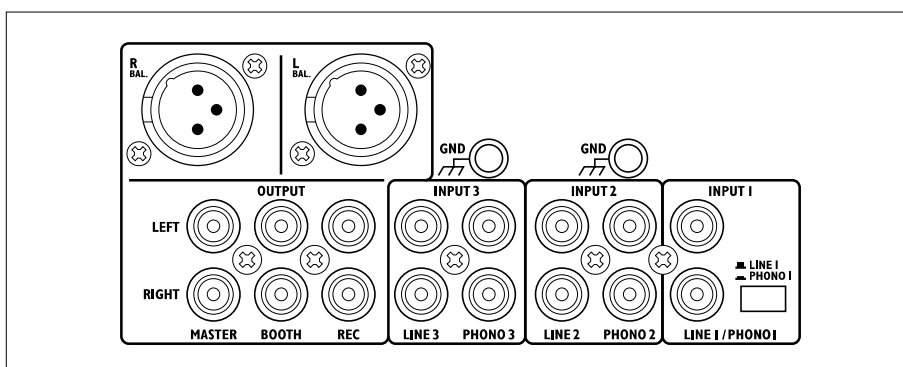

### MPX-1/BK

Order No. 0202170



#### Stereo DJ mixer

- 2 stereo input channels, each with gain control and 2-way equalizer, switchable phono/line
- DJ microphone channel with talkover, manually selectable
- Pre-fader listening (PFL) to the stereo input channels via adjustable headphone output
- Replaceable crossfader for crossfading between the two input channels
- Particularly easy-sliding high-quality faders with additional guides
- Stereo LED level display

Model	MPX-1/BK
Mic input	1.5 mV, 49 dB, 1 x 6.3 mm jack
Line input	150 mV, 61 dB, 2 x RCA L/R
Phono input	3 mV, 2 x RCA L/R
Master output	1 V/600 Ω, 1 x RCA L/R
Record output	0.5 V/600 Ω, 1 x RCA L/R
Headphones	≥ 8 Ω, 1 x 6.3 mm jack
Frequency range	20-20,000 Hz
THD	0.1%
Equalizer bass	±12 dB/50 Hz
Equalizer treble	±12 dB/10 kHz
Talkover	-16 dB
Power supply	via encl. plug-in power supply
Dimensions	164 x 218 x 77 mm
Weight	1.2 kg

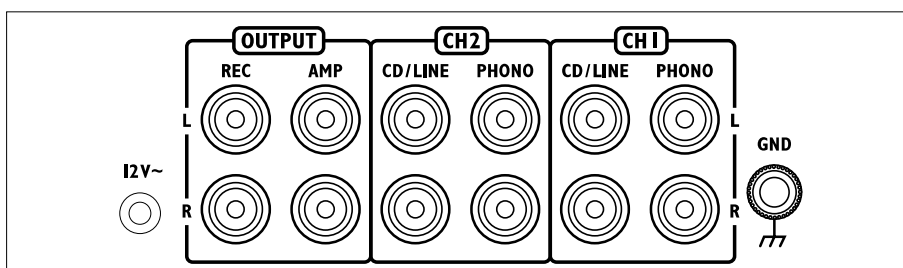



# Mixers

## Analogue Mixers

### MPX-206/SW

Order No. 0202480



#### 6-channel stereo mixer

- 4 stereo input channels, each with separate LED level display, switchable line/phono (channels 1-2) and line/line (channels 3-4), gain control, 3-way equalizer with cut function
- 1 DJ microphone channel with switchable talkover and 1 guest microphone channel, both channels with gain control as well as 2-way tone control
- 1 stereo effect way (send/return)
- 2 master outputs, each with beat LED and 1 booth output
- 1 record output
- LED level display, switchable between both master outputs
- Crossfader with assignment switches for channels 1-4 and cut switch function to suppress high frequencies, midrange and bass frequencies



- Adjustable headphone output
- Fader start for the stereo inputs (channels 1-4)
- Connection for gooseneck light GNL-404

Model	MPX-206/SW
Mic input	1.5 mV, 2 x 6.3 mm jack
Line input	150 mV, 3 x RCA L/R
CD input	150 mV, 3 x RCA L/R
Phono input	3 mV, 2 x RCA L/R
Effect return	135 mV, 1 x RCA L/R
Master output	1 V/600 Ω, 1 x 3-pole XLR L/R
Record output	300 mV/600 Ω, 1 x RCA L/R
Monitor output	1 V/600 Ω, 1 x RCA L/R
Effect send	300 mV/600 Ω, 1 x RCA L/R
Headphones	≥ 8 Ω, 6.3 mm jack
Gooseneck lamp	12 V/5 W, 4-pole XLR
Frequency range	20-20,000 Hz
THD	0.05%
S/N ratio	> 50 dB
Equalizer bass	+15 dB, -30 dB/50 Hz
Equalizer midrange	+15 dB, -30 dB/1 kHz
Equalizer treble	+15 dB, -30 dB/10 kHz
Talkover	-12 dB, switchable
Power supply	~ 230 V/50 Hz/14 VA
Dimensions	482 x 266 x 110 mm, 6 RS
Weight	6.48 kg

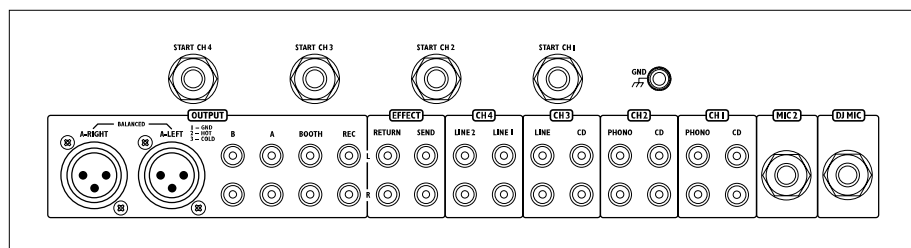

### MPX-205/SW

Order No. 0202190



#### Stereo DJ mixer

- 1 DJ mic, 4 stereo channels, switchable line/phono (1+2) and line/line (3+4)
- Stereo effect send/return
- 2 master outputs
- Automatic talkover and on-air switch for DJ mic
- LED level display, can be switched between the two master outputs and PFL
- 3-way equalizer with cut function for stereo channels
- 2-way tone control for DJ mic
- Gain control for each input
- Pre-fader listening (PFL) to the stereo inputs and outputs via adjustable headphone output
- Crossfader with assignment switches
- Connection for gooseneck light GNL-404



Model	MPX-205/SW
Mic input	1.5 mV, 1 x 6.3 mm jack
Line input	150 mV, 3 x RCA L/R
CD input	150 mV, 3 x RCA L/R
Phono input	3 mV, 2 x RCA L/R
Effect return	135 mV, 1 x RCA L/R
Master output	1 V/600 Ω, 1 x 3-pole XLR L/R
Record output	330 mV/600 Ω, 1 x RCA L/R
Monitor output	300 mV/600 Ω, 1 x RCA L/R
Effect send	1.2 V/600 Ω, 1 x RCA L/R
Headphones	≥ 8 Ω, 1 x 6.3 mm jack
Gooseneck lamp	12 V/5 W, 1 x 4-pole XLR
Frequency range	20-20,000 Hz
THD	0.05%
S/N ratio	> 50 dB
Equalizer bass	+15 dB, -30 dB/50 Hz
Equalizer midrange	+15 dB, -30 dB/1 kHz
Equalizer treble	+15 dB, -30 dB/10 kHz
Talkover	-12 dB, automatic
Power supply	~ 230 V/50 Hz/14 VA
Dimensions	482 x 222 x 110 mm, 5 RS
Weight	4.3 kg

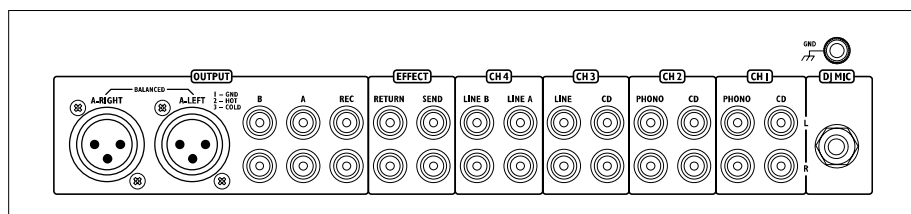



### MPX-410DMP

Order No. 0202850



#### Stereo DJ mixer with integrated MP3 player and Bluetooth receiver

Mixer:

- 4 stereo input channels, switchable MP3/phono/line (channel 1), aux/phono/line (channel 2) and aux/mic/line (channels 3-4)
  - Input channels, each with gain control and 2-way tone control
  - 1 DJ microphone channel, adjustable, with 2-way tone control
  - Adjustable headphone output with pre-fader listening (PFL) to the stereo input channels and the master output
  - Crossfader with assignment switches
  - Master output with stereo LED level display
  - Additional outputs booth and record
- MP3 player with Bluetooth receiver, USB interface and SD/MMC card slot:
- Alphanumeric display

- Bluetooth receiver for wireless connection of laptops, smartphones or tablet PCs
- USB storage media can be connected directly (e.g. USB flash drive)
- For SD/MMC cards up to 32 GB (FAT16/FAT32), available at option
- Repeat function
- Blue backlit display

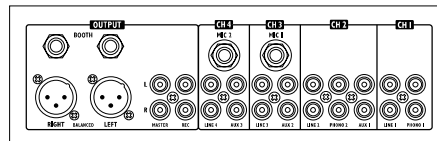

Model	MPX-410DMP
Mic input	1.5 mV, 3 x 6.3 mm jack
Line input	200 mV, 4 x RCA L/R
Phono input	2 mV, 2 x RCA L/R
Aux input	200 mV, 3 x RCA L/R
Master output	1 V, 1 x 3-pole XLR (bal.) 1 x RCA L/R
Record output	400 mV, 1 x RCA L/R
Booth output	1 V, 1 x 6.3 mm jack L/R
Headphones	≥ 8 Ω, 1 x 6.3 mm jack
Bluetooth	yes
Frequency range	20-20,000 Hz
THD	< 0.15%
S/N ratio	> 60 dB, unweighted
Equalizer bass	±15 dB/50 Hz (channels 1-4) ±12 dB/100 Hz (DJ mic)
Equalizer treble	±15 dB/10 kHz (channels 1-4) ±12 dB/7 kHz (DJ mic)
Power supply	~ 230 V/50 Hz/15 VA
Dimensions	482 x 88 x 125 mm, 2 RS
Weight	2.9 kg

### MPX-622/SW

Order No. 0202210



#### 6-channel stereo audio mixer, particularly suitable for PA and DJ applications.

- 2 mono microphone channels with talkover switch and 2-way tone control
- 4 stereo input channels, switchable phono/line (channels 1 and 2) or line/line (channels 3 and 4)
- 1 stereo master output
- 1 stereo record output, independent of the master

- 3-way equalizer with centre click for master output and record output
- Pre-fader listening to each stereo input channel and the master output via adjustable stereo headphone output
- Switchable crossfader for crossfading between channels 1-4, any assignment possible
- Stereo LED level display



Model	MPX-622/SW
Mic input	1 mV, 2 x 6.3 mm jack
Line input	150 mV, 5 x RCA L/R
CD input	150 mV, 1 x RCA L/R
Phono input	3 mV, 2 x RCA L/R
Master output	0.775 V/600 Ω, 1 x RCA L/R
Record output	0.775 V/600 Ω, 1 x RCA L/R
Headphones	≥ 8 Ω, 1 x 6.3 mm jack
Frequency range	20-20,000 Hz
THD	0.1%
S/N ratio	65 dB
Equalizer bass	±10 dB/100 Hz
Equalizer midrange	±10 dB/1 kHz
Equalizer treble	±10 dB/10 kHz
Talkover	-15 dB
Power supply	~ 230 V/50 Hz/10 VA
Dimensions	482 x 89 x 95 mm, 2 RS
Weight	2.4 kg

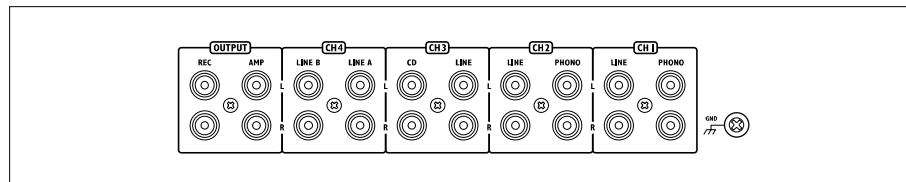

### MPX-44/SW

Order No. 0202420



#### 6-channel stereo DJ mixer, with black brushed aluminium front panel.

- 6 input channels (4 stereo ways, 2 microphone ways)
- Stereo input channels, switchable 2 x phono/line and 2 x line/line, with LED level display of the stereo master
- Input channels, each with gain control and 3-way equalizer, stereo input channels with cut function
- DJ mic with automatic talkover, PAD switch and on-air switch
- Mic with PAD switch and on-air switch
- Switches illuminate blue when activated



- Adjustable, crossfader-controlled headphone output with pre-fader listening (PFL) to the stereo input channels and mic
- Replaceable crossfader with assignment switches
- Especially easy-sliding high-quality faders
- Master output with stereo LED level display
- Additional outputs booth and zone
- Connection for gooseneck light GNL-204

Model	MPX-44/SW
Mic input	1.5 mV, 2 x 6.3 mm jack
Line input	150 mV, 5 x RCA L/R
CD input	150 mV, 1 x RCA L/R
Phono input	3 mV, 2 x RCA L/R
Master output	1 V/600 Ω, 1 x 3-pole XLR, 1 x RCA L/R
Record output	0.5 V/600 Ω, 1 x RCA L/R
Monitor output	1 V/600 Ω (zone), 1 x RCA L/R
Booth output	1 V/600 Ω, 1 x RCA L/R
Headphones	≥ 8 Ω, 1 x 6.3 mm jack
Gooseneck lamp	12 V/0.75 W, 1 x BNC
Frequency range	20-20,000 Hz
THD	0.1%
S/N ratio	61 dB, unweighted
Equalizer bass	+12 dB, -12 dB/50 Hz (mic) +15 dB, -30 dB/50 Hz (channels 1-4)
Equalizer midrange	+12 dB, -12 dB/1 kHz (mic) +15 dB, -30 dB/1 kHz (channels 1-4)
Equalizer treble	+12 dB, -12 dB/10 kHz (mic) +15 dB, -30 dB/10 kHz (channels 1-4)
Talkover	-16 dB, automatic
Power supply	~ 230 V/50 Hz/20 VA
Dimensions	482 x 177 x 105 mm, 4 RS
Weight	3.6 kg

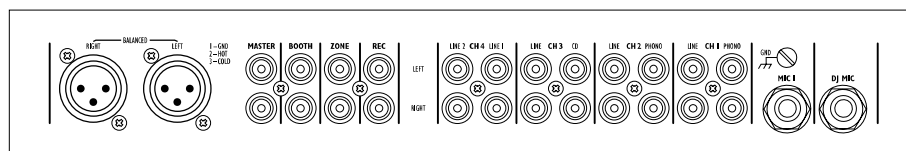

# Mixers

## Analogue Mixers

### MMX-602/SW

Order No. 0202230



**Microphone line mixer, 6 channels.**

- 6 stereo line inputs, 6 balanced mono microphone inputs, switchable
- Adjustable automatic talkover (-12 dB), switchable for channel 1 or channels 1+2
- Balance control for each stereo input channel
- 3-way equalizer
- 12 V phantom power can be activated as required
- LED VU meter, peak LED
- Master output and record output

- Output can be switched stereo/mono
- Adjustable headphone output
- 482 mm (19") rack installation, 1 RS



Model	MMX-602/SW
Mic input	1 mV/6.6 k $\Omega$ , 6 x 3-pole XLR, bal.
Line input	100 mV/10 k $\Omega$ , 6 x RCA L/R
Master output	1 V/600 $\Omega$ , 1 x RCA L/R 1 x 3-pole XLR L/R, bal.
Record output	310 mV/600 $\Omega$ , 1 x RCA L/R
Headphones	> 8 $\Omega$ , 1 x 6.3 mm jack
Frequency range	20-20,000 Hz
THD	0.1%
S/N ratio	62 dB, unweighted
Equalizer bass	$\pm$ 12 dB/50 Hz
Equalizer midrange	$\pm$ 12 dB/1 kHz
Equalizer treble	$\pm$ 12 dB/10 kHz
Talkover	-12 dB, manual
Power supply	$\sim$ 230 V/50 Hz/12 VA
Dimensions	482 x 47 x 208 mm, 1 RS
Weight	2.8 kg

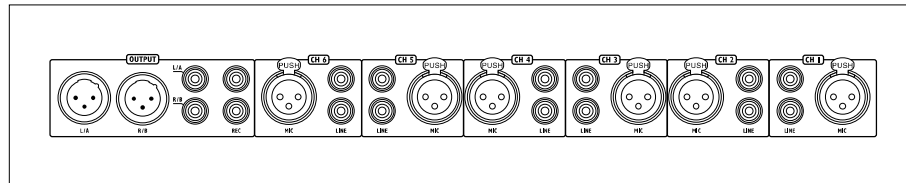

### ULM-164/SW

Order No. 0202240



**Universal line mixer, 6 channels.**

- 6 stereo inputs/mono inputs
- 2 stereo outputs, independent of each other (master 1 via RCA and 6.3 mm jack), 1 mono output
- 3-way equalizer
- LED VU meter, switchable for both outputs
- Clip LED for each channel
- Balance controls with centre click for the stereo input channels

- Extended muting function
- Adjustable headphone output
- 482 mm (19") rack installation, 1 RS



Model	ULM-164/SW
Line input	150 mV/50 k $\Omega$ (stereo), 6 x RCA L/R 150 mV/25 k $\Omega$ (mono), 6 x 6.3 mm jack, unbal.
Master output	1 V/600 $\Omega$ (stereo), 2 x RCA (1 x 6.3 mm) L/R 2 V/600 $\Omega$ (mono), 1 x 6.3 mm jack
Headphones	$\geq$ 8 $\Omega$ , 1 x 6.3 mm jack
Frequency range	20-20,000 Hz
THD	0.05%
S/N ratio	69 dB, unweighted
Equalizer bass	$\pm$ 12 dB/80 Hz
Equalizer midrange	$\pm$ 12 dB/1 kHz
Equalizer treble	$\pm$ 12 dB/10 kHz
Power supply	$\sim$ 230 V/50 Hz/10 VA
Dimensions	482 x 48 x 175 mm, 1 RS
Weight	2.3 kg

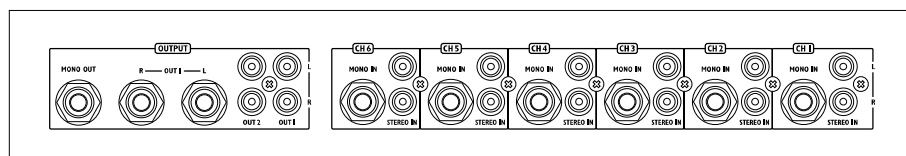

### MMX-30

Order No. 0252540

**Compact 3-channel stereo line mixer**

- 3 stereo input channels with one level control each
- 1 stereo master output, adjustable
- RCA connections for input channels and output
- 2 stereo headphone outputs, common control
- Signal/peak LEDs for the input channels and peak LED for the output

Model	MMX-30
Line input	40 mV, 3 x RCA L/R
Master output	4 V, 1 x RCA L/R
Headphones	2 x 10 mW/2 x 32 $\Omega$ , 2 x 6.3 mm jack
Frequency range	5-30,000 Hz
THD	< 0.1%
S/N ratio	> 66 dB
Power supply	via end. plug-in power supply
Dimensions	147 x 50 x 119 mm
Weight	693 g



### MMX-31

Order No. 0244450

**Microphone mixer**

Quick method to mix three microphones to one microphone input and still allow for individual level adjustment.

- 3 mono microphone channels (6.3 mm jack) with separate level control each
- 1 mono output via 3 m connection cable with 6.3 mm plug

Model	MMX-31
Mic input	3 x 6.3 mm mono jack
Master output	1 x 6.3 mm mono jack
Power supply	not required
Dimensions	127x48x72 mm
Weight	200 g

- Passive operation, no power supply required
- Can also be used as an extension for microphone inputs which are difficult to access
- Dimensions: 127 x 48 x 72 mm
- Weight: 255 g



## MX-110

Order No. 0203160



### 1-channel USB recording interface

- Integrated USB audio interface
- Full-duplex USB port (allows for simultaneous recording and reproduction)
- 1 mono input channel with XLR input (mic) and 6,3 mm input (switchable mic/line)
- Selectable 20 dB attenuation and LED level display
- 1 additional stereo input

Model	MX-110
Mic input	2.5 mV, 1 x 3-pole XLR
Line input	45 mV, 1 x 6.3 mm jack 11 kΩ (line)/460 kΩ (inst.)
Aux input	1.25 V, 1 x 3.5 mm jack
Master output	500 mV, 1 x 6.3 mm jack L/R
Aux output	500 mV, 1 x 3.5 mm jack
Headphones	≥ 16 Ω, 1 x 3.5 mm jack
Frequency range	20-20,000 Hz
THD	≤ 0.03%
Crosstalk	92 dB
Power supply	via USB interface = 5 V/500 mA
Operating voltage (possible alternative)	= 5 V
Power supply (possible alternative)	500 mA
Dimensions	120 x 50 x 110 mm
Weight	498 g



## MX-210

Order No. 0203170



### 2-channel USB recording interface

- Integrated USB audio interface
- Full-duplex USB port (allows for simultaneous recording and reproduction)
- 2 mono input channels with XLR input (mic) and 6,3 mm input (switchable mic/line)
- Selectable 20 dB attenuation and LED level display
- Input channels switchable mono/stereo
- 1 additional stereo input

Model	MX-210
Mic input	2.5 mV, 2 x 3-pole XLR
Line input	45 mV, 1 x 6.3 mm jack 11 kΩ (line)/460 kΩ (inst.)
Aux input	1.25 V, 1 x 3.5 mm jack
Master output	500 mV, 2 x 6.3 mm jack L/R
Aux output	500 mV, 1 x 3.5 mm jack
Headphones	≥ 16 Ω, 1 x 3.5 mm jack
Frequency range	20-20,000 Hz
THD	≤ 0.03%
Crosstalk	92 dB
Power supply	via USB interface = 5 V/500 mA
Dimensions	160 x 50 x 110 mm
Weight	634 g



## MMX-11USB

Order No. 0202840



### 2-channel miniature audio mixer, with 3 inputs and USB interface.

- Integrated USB audio interface
- Full-duplex USB port (allows for simultaneous recording and reproduction)
- 1 mono input channel with gain control, 2-way equalizer and pan pot, peak LED
- 1 stereo input channel with level control, 2-way equalizer and balance control
- Tape record/play connections

Model	MMX-11USB
Mic input	0.5 mV, 1 x 3-pole XLR
Line input	150 mV (stereo), 1 x RCA L/R 2 mV (mono), 6,3 mm jack
Tape (play)	420 mV, 1 x RCA L/R
Master output	6 V max., 1 x 3.5 mm jack
Booth output	6 V max., 1 x 3.5 mm jack
Tape (rec)	1 x RCA L/R
Frequency range	20-20,000 Hz
THD	< 0.05%
S/N ratio	81 dB, weighted
Equalizer bass	±15 dB/80 Hz
Equalizer treble	±15 dB/12 kHz
Power supply	via USB interface or via encl. power supply
Dimensions	102 x 45 x 140 mm
Weight	430 g



## MPX-20USB

Order No. 0202860



### 3-channel stereo DJ mixer, with USB interface. Plug and mix!

- Integrated USB audio interface
- Full-duplex USB port (allows for simultaneous recording and reproduction)
- 1 microphone input channel
- 2 stereo input channels, switchable line/phono and USB/line/phono
- 1 stereo output channel (master)

Model	MPX-20USB
Mic input	1 mV, 1 x 6.3 mm jack
Line input	450 mV, 2 x RCA L/R
Phono input	9 mV, 2 x RCA L/R
Master output	1 V, 1 x RCA L/R
Record output	1 V, 1 x RCA L/R
Headphones	≥ 8 Ω, 1 x 3.5 mm jack, 1 x 6.3 mm jack
Frequency range	20-20,000 Hz
THD	0.1%
S/N ratio	63 dB, unweighted
Power supply	= 5 V/500 mA via USB interface
Dimensions	150 x 70 x 140 mm
Weight	700 g

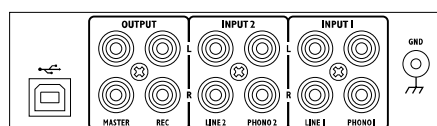

## Mixers Recording Interfaces



### SONGWRITER-1

Order No. 0230654

**Recording bundle for songwriters**, consisting of:

- 1 x large diaphragm condenser microphone ECMS-70 for vocal recordings
- 1 x compact large diaphragm condenser microphone ECMS-60 for recording e.g. acoustic guitars
- 1 x microphone pop filter KM-23956
- 2 x microphone floor stand MS-20/SW
- 2 x XLR cable MECN-600/SW, 6 m, NEUTRIK connectors
- 1 x 2-channel USB recording interface MX-2IO

For additional specifications, please refer to individual items.







## PODCASTER-1

Order No. 0230653

**Recording bundle for podcasters**, consisting of:

- 1 x large diaphragm condenser microphone ECMS-70
- 1 x microphone pop filter KM-23956
- 1 x desktop microphone stand MS-12
- 1 x XLR cable MECN-200/SW, 2 m, NEUTRIK connectors
- 1 x 1-channel USB recording interface MX-110

For additional specifications, please refer to individual items.



# Audio Tools

## DI Boxes/Transformers

### DIB-100

Order No. 0241140

#### DI box

- 3-fold attenuation switch (0/-20/-40 dB)
- Ground lift switch
- Instrument feed-through output
- Wideband balancing transformer
- Robust metal housing

Model	DIB-100
Frequency range	15-30,000 Hz
Input impedance	50 k $\Omega$
Output impedance	600 $\Omega$ (bal.), 50 k $\Omega$ (unbal.)
Gain	0/-20/-40 dB
Transmission ratio	10:1
Dimensions	74 x 45 x 130 mm
Weight	560 g
Inputs	1 x 6.3 mm jack, unbal.
Outputs	1 x 6.3 mm jack, unbal., par. out XLR, bal.



### DIB-102

Order No. 0247060

#### 2-channel DI box

- 3-fold attenuation switch (0/-20/-40 dB) for each channel
- 1 ground lift switch for each channel
- 1 instrument feed-through output for each channel
- Wideband balancing transformer
- Robust metal housing

Model	DIB-102
Frequency range	15-30,000 Hz
Input impedance	50 k $\Omega$
Output impedance	600 $\Omega$ , XLR 50 k $\Omega$ , jack
Transmission ratio	10:1
Dimensions	148 x 50 x 130 mm
Weight	755 g
Inputs	2 x 6.3 mm jack, unbal.
Outputs	2 x 6.3 mm jack, unbal., par. out 2 x XLR, bal.



### LTR-102

Order No. 0241800

#### Line transformer

- Balanced and unbalanced inputs and outputs
- Output impedance can be switched from 1:1/600  $\Omega$  to 2:1/150  $\Omega$
- Phase can be switched from 0° to 180°
- Ground lift switch
- Wideband balancing transformer
- Robust metal housing

Model	LTR-102
Frequency range	20-25,000 Hz
Input signal	5 V
Input impedance	600 $\Omega$
Output impedance	600 $\Omega$ /150 $\Omega$
Transmission ratio	1:1/2:1
Dimensions	120 x 44 x 90 mm
Weight	545 g
Inputs	1 x 6.3 mm jack, bal. 1 x XLR, bal.
Outputs	1 x 6.3 mm jack, bal. 1 x XLR, bal.



### FGA-202

Order No. 0251660

#### Professional 2-channel line transformer

- Prevents hum loops
- 2 inputs via balanced comb. jacks XLR/6.3 mm (600  $\Omega$ )
- 2 galvanically isolated XLR outputs (600  $\Omega$ ) with ground lift switch
- Frequency range: 20-20,000 Hz

- Robust metal housing with very good shielding qualities, suitable for stage applications
- Dimensions: 125 x 55 x 75 mm
- Weight: 650 g



### FGA-102

Order No. 0251650

#### Professional stereo line transformer

- Prevents hum loops
- Galvanically isolated inputs and outputs
- Gold-plated RCA connections (600  $\Omega$ )
- Frequency range: 20-20,000 Hz
- Robust metal housing with very good shielding qualities, suitable for stage applications

- Dimensions: 125 x 55 x 75 mm
- Weight: 650 g





## LS-280/SW

Order No. 0202220



### 8-way line splitter

- 2 separate inputs
- Selectable operating modes:
  - 1. input A to 4 outputs,
  - input B to 4 outputs
  - 2. input A to 8 outputs
- XLR connection and gain control for each input and output

Model	LS-280/SW
Frequency range	20-20,000 Hz
Input signal	100 mV
Input impedance	15 k $\Omega$
Output signal	1 V
Output impedance	100 $\Omega$
S/N ratio	70 dB, unweighted
THD	< 0.03%
Power supply	~ 230 V/50 Hz/10 VA
Dimensions	482 x 48 x 205 mm, 1 RS
Weight	2.3 kg

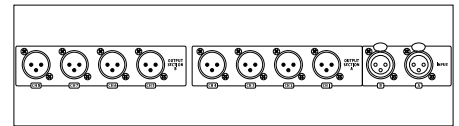

## LMS-808

Order No. 0202160



### Microphone line mixer/line splitter

- Multifunctional device with three selectable operating modes:
  - Mixer operation
  - Line splitter operation
  - Level matching amplifier operation
- 6 mono input channels, each with switchable 12 V phantom power, pan pot, signal/clip LED
- 2 mono line input channels, each with level control and signal/clip LED

Model	LMS-808
Mic input	1 mV/6.6 k $\Omega$ (mic), 6 x XLR, bal.
Line input	250 mV/30 k $\Omega$ , 2 x XLR, bal.
	100 mV/40 k $\Omega$ , 6 x XLR, bal.
Master output	1 V/200 $\Omega$ , 6 x XLR, bal. (mono), 1 x XLR L/R, bal. (stereo)
Frequency range	10-30,000 Hz
THD	0.02%
S/N ratio	81 dB, weighted
Crosstalk	-63 dB
Power supply	~ 230 V/50 Hz/10 VA
Dimensions	482 x 48 x 200 mm, 1 RS
Weight	2.9 kg

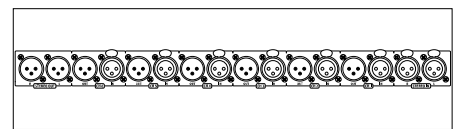

## LSP-102

Order No. 0251680

**2-channel 3-way line splitter**, (2 inputs/6 outputs), e.g. for connecting one mixer to several amplifiers.

- 1 balanced XLR input (600  $\Omega$ ) for each channel
- 2 galvanically isolated, balanced XLR outputs (600  $\Omega$ ) with ground lift switch for each channel
- 1 balanced XLR direct output for each channel
- Frequency range: 20-20,000 Hz

Model	LSP-102
Frequency range	20-20,000 Hz
Input impedance	600 $\Omega$
Output impedance	600 $\Omega$
Dimensions	160 x 55 x 105 mm
Weight	909 g
Inputs	2 x XLR, bal.
Outputs	6 x XLR, bal.

- Dimensions: 160 x 55 x 105 mm



## LC-31

Order No. 0251670

**2-channel 2-way line combiner**, (4 inputs/2 outputs), e.g. for connecting 2 mixers to one amplifier.

- 1 galvanically isolated, balanced XLR input (600  $\Omega$ ) with ground lift switch for each channel
- 1 balanced XLR direct input for each channel
- 1 balanced XLR output (600  $\Omega$ ) for each channel
- Frequency range: 20-20,000 Hz

Model	LC-31
Frequency range	20-20,000 Hz
Input impedance	600 $\Omega$
Output impedance	600 $\Omega$
Dimensions	160 x 55 x 85 mm
Weight	761 g
Inputs	4 x XLR, bal.
Outputs	2 x XLR, bal.

- Dimensions: 160 x 55 x 85 mm



## MC-31

Order No. 0251690

**3-way microphone combiner**, (3 inputs/1 output), for connecting 3 microphones to e.g. one microphone input of a mixer.

- Balanced XLR connections (200  $\Omega$ )
- Frequency range: 20-20,000 Hz

Model	MC-31
Frequency range	20-20,000 Hz
Input impedance	200 $\Omega$
Dimensions	125 x 55 x 75 mm
Weight	563 g
Inputs	3 x XLR, bal.
Outputs	1 x XLR, bal.



## MPS-1

Order No. 0243790

**Microphone splitter**, for distributing one input signal to two outputs, e.g. monitor mixer and main mixer.

- Galvanically isolated output with ground lift switch and feed-through output

Model	MPS-1
Frequency range	35-30,000 Hz
Input impedance	600 $\Omega$
Output impedance	600 $\Omega$
Dimensions	100 x 80 x 40 mm
Weight	310 g
Inputs	1 x XLR, bal.
Outputs	2 x XLR, bal.



# Audio Tools Preamplifiers

## MPA-202

Order No. 0320710

### 2-channel low-noise microphone preamplifier

- 2 microphone inputs, XLR, bal.
- Gain control, 11 steps, 20-70 dB
- 2 level controls  $\pm 5$  dB
- LED green/red for indicating operation/peak
- Phantom power +12 V, can be activated as required
- Microphone phase, switchable for each channel
- Low cut: 15-240 Hz, continuously adjustable
- Subsonic filter 15 Hz, 18 dB/oct.
- 2 line outputs, XLR bal.
- 2 line outputs, RCA unbal.

Model	MPA-202
Frequency range	20-20,000 Hz
Input sensitivity	0.16-150 mV switchable
Input impedance	4.4 k $\Omega$ (bal.) 2.2 k $\Omega$ (unbal.)
Output signal	1-14 V (line, bal.) 1-7 V (line, stereo)
Output impedance	100 $\Omega$ /600 $\Omega$
Gain	15-75 dB
Crossover frequency	15-240 Hz, 6 dB/oct. (low cut), 15 Hz, 18 dB/oct. (subsonic)
Low cut	100 Hz
S/N ratio	> 68 dB, unweighted > 87 dB, weighted
THD	< 0.01%
Power supply	via encl. plug-in power supply
Dimensions	116 x 55 x 135 mm
Weight	980 g



## MPA-102

Order No. 0320650

### 1-channel low-noise microphone preamplifier, for mains operation or battery operation.

- 1 microphone input, XLR, bal.
- Gain control, 11 steps, 20-70 dB
- LED green/red for indicating operation/peak
- Phantom power +24 V, can be activated as required
- Switchable microphone phase
- Low cut: 100 Hz, high cut: 12 kHz, 12 dB/oct., switchable
- 1 preamplifier output
- 1 stereo line input
- 1 stereo line output
- Level control and pan pot for mixing the microphone signal to the stereo line channel

Model	MPA-102
Frequency range	20-20,000 Hz
Input sensitivity	0.3-150 mV, switchable
Input impedance	2.2 k $\Omega$ (mic) 10 k $\Omega$ (line)
Output signal	1-12 V (line, bal.) 1-6 V (line, stereo)
Output impedance	100 $\Omega$
Gain	20-70 dB (mic) 0 dB (line)
Crossover frequency	100 Hz/-3 dB, 12 dB/oct. (low cut) 12 kHz/-3 dB, 12 dB/oct. (high cut)
Low cut	100 Hz
S/N ratio	> 66 dB, unweighted (mic) 80 dB, unweighted (line)
THD	< 0.01%
Power supply	via encl. plug-in power supply; alternatively 3 x 9 V battery
Dimensions	116 x 55 x 125 mm
Weight	978 g



## SPR-6

Order No. 0210640

**Stereo phono anti-distortion preamplifier acc. to RIAA**, for connecting a turntable to the aux input or line input of a hi-fi system, a mixer or an amplifier, etc. Low hum effect due to metal case and supplied plug-in power supply.

Model	SPR-6
Frequency range	20-20,000 Hz
Input signal	5 mV/47 k $\Omega$
Output signal	450 mV/100 k $\Omega$
S/N ratio	> 50 dB
Power supply	via encl. plug-in power supply
Dimensions	67 x 37 x 121 mm
Weight	200 g



## MPR-1

Order No. 0212010

**1-channel microphone preamplifier**, with switchable phantom power.

- 1 microphone input, XLR, bal. or 6.3 mm jack, bal.
- Gain control: up to 50 dB max.
- Clip LED
- 30 V phantom power, can be activated as required

Model	MPR-1
Frequency range	10-30,000 Hz
Input signal	3.5 mV (XLR, bal.) 16 mV (jack, bal.)
Input impedance	10 k $\Omega$
Output signal	1 V
Gain	50 dB (with bal. connection) 44 dB (with unbal. connection)
S/N ratio	58 dB
THD	0.1%
Power supply	via encl. plug-in power supply
Dimensions	113 x 92 x 40 mm
Weight	345 g



## MPR-6

Order No. 0210680

**Microphone preamplifier**, for connecting up to 2 microphones to a line input of a hi-fi system, an amplifier or a mixer.

- Stereo or 2 x mono
- Wide frequency range
- Black metal case
- Supplied with plug-in power supply

Model	MPR-6
Frequency range	5-40,000 Hz
Input signal	2 mV/1 V output
Input impedance	10 k $\Omega$
Output signal	max. 3.2 V/47 k $\Omega$
Gain	53 dB
S/N ratio	63 dB
THD	0.05%
Power supply	via encl. plug-in power supply
Dimensions	67 x 37 x 121 mm
Weight	215 g



## PPA-100/SW

Order No. 0244190



### Stereo headphone amplifier

- 6 separate headphone amplifiers, each with 1 level control and 1 signal/clip LED as well as main/solo switching
- 1 input (solo) per amplifier, switchable to common main input (main)
- Main input with low/high selector switch for matching the input signal
- Inputs: solo (stereo) 6 x 6.3 mm jack, main (stereo) 2 x 6.3 mm jack, 2 x RCA L/R
- Outputs: headphones (stereo) 6 x 6.3 mm jack

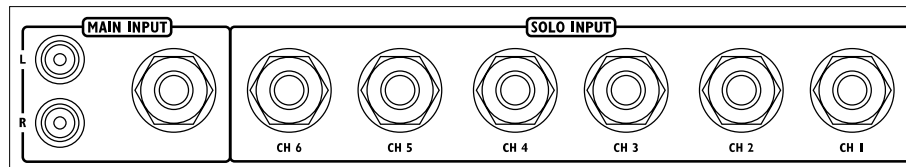

Model	PPA-100/SW
Frequency range	5-30,000 Hz
Input signal	250 mV/50 kΩ (solo) 250 mV/50 kΩ (main low) 2.2 V/60 kΩ (main high)
Output signal	2 x 16 mW/8 Ω 2 x 45 mW/32 Ω 2 x 75 mW/600 Ω
S/N ratio	> 60 dB
Channel separation	50 dB
THD	0.02%
Power supply	~ 230 V/50 Hz/11 VA
Dimensions	482 x 44 x 185 mm, 1 RS
Weight	2.3 kg

## PPA-4

Order No. 0243770

### Stereo headphone amplifier

- 4 separate headphone amplifiers in one housing
- 1 level control each per amplifier
- 6.3 mm stereo input
- 6.3 mm stereo outputs

Model	PPA-4
Frequency range	20-20,000 Hz
Input signal	300 mV
Output signal	2 x 16 mW/8 Ω, 2 x 35 mW/32 Ω, 2 x 15 mW/600 Ω (per headphone)
S/N ratio	64 dB
THD	0.1%
Power supply	via encl. plug-in power supply
Dimensions	117 x 93 x 40 mm
Weight	560 g
Inputs	1 x 6.3 mm jack
Outputs	4 x 6.3 mm jack



## HPR-6

Order No. 0244210

**Efficient stereo headphone amplifier**, can also be used as a small power amplifier for 4-8 Ω speaker systems

- Robust metal housing
- Stereo RCA input
- 6.3 mm stereo output
- Volume control and balance control

Model	HPR-6
Frequency range	19-40,000 Hz
Input signal	110 mV-4 V
Output signal	2 x 525 mW/2 x 1,500 mW/4 Ω, 2 x 330 mW/2 x 750 mW/8 Ω, 2 x 114 mW/2 x 200 mW/32 Ω
S/N ratio	69 dB
THD	1%
Power supply	via encl. plug-in power supply
Weight	288 g
Inputs	2 x RCA L/R
Outputs	1 x 6.3 mm jack



# Audio Tools

## Headphones

### MD-5000DR

Order No. 0220860

**Stereo headphones**, for applications with drums and in the studio.

- Perfectly closed system for suppressing ambient noise
- Good bass reproduction
- Extra secure fit
- Padded ear cushions
- 3 m helix cable with single-sided cable inlet
- Right-angle 3.5 mm plug, gold-plated, with thread for a secure connection to supplied 6.3 mm adapter

Model	MD-5000DR
Headphone driver	neodymium, Ø 40 mm
Type of transducer	dynamic
Max. input power	500 mW
Transmission range, headphones	10-20,000 Hz
Nominal impedance, headphones	32 Ω
Headphone sensitivity	105 dB/mW
Cable	3 m, single-sided cable inlet
Plug	3.5 mm plug, gold-plated
Adapter	6.3 mm plug, gold-plated
Weight w/o cable	365 g



### MDH-6300

Order No. 0221090

#### Mono hand-held DJ headphone

- Powerful neodymium magnet driver Ø 50 mm
- Closed system
- Movable earpiece
- Padded ear cushion
- Ergonomic padded handle
- Removable helix connection cable (1.3-2.8 m) with latchable XLR inline jack and right-angle 6.3 mm stereo plug
- Supplied with transport bag

Model	MDH-6300
Headphone driver	neodymium, Ø 50 mm
Type of transducer	dynamic
Max. input power	3,500 mW
Transmission range, headphones	10-22,000 Hz
Nominal impedance, headphones	46 Ω
Headphone sensitivity	96 dB/mW
Cable	1.3-2.8 m
Plug	6.3 mm plug
Weight w/o cable	152 g



## FLY-16SET

Order No. 0259854

**16-channel wireless PA audio transmission set**, with UHF PLL technology.

- Consisting of 16-channel wireless PA audio transmitter FLY-16T and 16-channel wireless PA audio receiver FLY-16R
- For analogue wireless transmission of line audio signals in PA systems
- Frequency range: 823-832 MHz
- 16 pre-programmed channels, selectable
- Up to 8 intermodulation-free channels
- Audio transmission range: 30-17,000 Hz
- Compact size
- For further specifications, please refer to individual items



## FLY-16T

Order No. 0259580

**16-channel wireless PA audio transmitter**, with UHF PLL technology.

- For analogue wireless transmission of line audio signals in PA systems
- Frequency range: 823-832 MHz
- 16 pre-programmed channels, selectable
- Up to 8 intermodulation-free channels
- Indication for channel and battery status
- Supplied with USB cable

Model	FLY-16T
Description	16-channel wireless PA audio transmitter
Carrier frequency range	823-832 MHz
Audio frequency range	30-17,000 Hz
THD	0.3%
Transmitting power	10 mW
Operating range	approx. 90 m
Power supply transmitter	1 x 1.5 V batt. AA size, = 5 V/150 mA via micro USB jack
Dimensions transmitter	22 x 23 x 116 mm
Weight transmitter	54 g
Connections transmitter	3-pole XLR jack



## FLY-16R

Order No. 0259570

**16-channel wireless PA audio receiver**, with UHF PLL technology.

- For analogue wireless transmission of line audio signals in PA systems
- Frequency range: 823-832 MHz
- 16 pre-programmed channels, selectable
- Up to 8 intermodulation-free channels
- Multiple receivers FLY-16R can be operated via one transmitter FLY-16T
- Indication for channel and battery status
- Supplied with USB cable

Model	FLY-16R
Description	16-channel wireless PA audio receiver
Carrier frequency range	823-832 MHz
Audio frequency range	30-17,000 Hz
THD	0.3%
Power supply receiver	1 x 1.5 V batt. AA size, = 5 V/150 mA via micro USB jack
Dimensions receiver	22 x 23 x 102 mm
Weight receiver	25 g
Connections receiver	3-pole XLR plug



**There are restrictions or requirements in the EU!  
Please read the notes on wireless systems in the section "IMPORTANT INFORMATION"!**

# Audio Tools

## Signal Processing

### DSP-26

Order No. 0255780



#### Digital speaker management system

- 2 analogue inputs and 6 analogue outputs (XLR, bal.)
- 64-bit DSP, sampling rate: 96 kHz
- Dynamic range: > 114 dB
- Latency: < 1 ms
- Routing fader for user-defined routing of the inputs to the outputs
- Graphic user interface, PC editing software
- 50 user presets can be stored
- Remote control via USB
- Dot matrix display with 2 x 16 characters
- VU meter with 8 LEDs for each channel, level display and peak
- 482 mm (19") rack installation, 1 RS

#### Input (data for each channel)

- Gain control: -48 dB to +12 dB

#### Output (data for each channel)

- Gain control: -48 dB to +12 dB
- 10 parametric equalizers with 8 types of filters each
- 2 crossover networks with Butterworth, Linkwitz-Riley and Bessel filters as well as individually adjustable types of filters from 6 to 24 dB/oct.
- Delay to be switched between time (ms) and distance (m): 5 ms max, in steps of 10 µsec or 1.71 m max in steps of 3,4 mm
- Limiter, threshold: from -48 dBu to +9 dBu

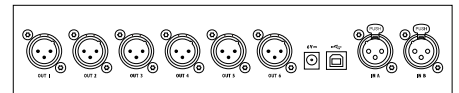

Model	DSP-26
Frequency range	10-30,000 Hz
Input signal	≤ 10 V
Output signal	≤ 2 V
Crossover frequency	70 Hz-1 kHz, 12 dB/oct., 910 Hz-8 kHz, 12 dB/oct., subwoofer 80/120 Hz, 24 dB/oct.
S/N ratio	> 110 dB
THD	< 0,005%
Power supply	via encl. plug-in power supply
Dimensions	482 x 44 x 175 mm, 1 RS
Weight	1.56 kg

### DSM-26LAN

Order No. 0255760



#### Digital speaker management system

- 2 analogue inputs and 6 analogue outputs (XLR, bal.)
- 1 x AES/EBU digital input, stereo
- 64-bit DSP, sampling rate: 96 kHz
- Dynamic range: > 118 dB
- Latency: 0.64 ms
- 80 user presets can be stored
- Remote control via USB or TCP/IP LAN, iOS app
- Dot matrix display with 2 x 16 characters
- VU meter with 4 LEDs for each channel, level display and peak
- 482 mm (19") rack installation, 1 RS

#### Input (data for each channel)

- Gain control: -48 dB to +12 dB
- 10 parametric equalizers with 8 types of filters each
- 2 crossover networks
- Delay
- Limiter threshold: from -48 dBu to +24 dBu
- Compressor release time: 10 dB/s to 100 dB/s
- Mute

#### Output (data for each channel)

- Gain control: -48 dB to +12 dB
- 10 parametric equalizers with 8 types of filters each



Model	DSM-26LAN
Frequency range	10-40,000 Hz
Input signal	11 V max.
Output signal	4 V max.
S/N ratio	> 110 dB
THD	< 0,005%
Power supply	~ 230 V/50 Hz/15 VA
Dimensions	482 x 44 x 185 mm, 1 RS
Weight	2.13 kg
Inputs	2 x XLR, bal. 1 x AES/EBU, stereo
Outputs	6 x XLR, bal.
Other features	USB, LAN

### DSM-48LAN

Order No. 0255770



#### Digital speaker management system

- 4 analogue inputs and 8 analogue outputs (XLR, bal.)
- 1 x AES/EBU digital input, stereo
- 64-bit DSP, sampling rate: 96 kHz
- Dynamic range: > 118 dB
- Latency: 0.64 ms
- 80 user presets can be stored
- Remote control via USB or TCP/IP LAN, iOS app
- Dot matrix display with 2 x 16 characters
- 482 mm (19") rack installation, 1 RS

- 2 crossover networks
- Delay
- Limiter threshold: from -48 dBu to +24 dBu
- Compressor release time: 10 dB/s to 100 dB/s
- Mute

#### Output (data for each channel)

- Gain control: -48 dB to +12 dB
- 10 parametric equalizers with 8 types of filters each
- 2 crossover networks
- Delay
- Limiter threshold: from -48 dBu to +24 dBu
- Compressor release time: 10 dB/s to 100 dB/s



Model	DSM-48LAN
Frequency range	10-40,000 Hz
Input signal	11 V max.
Output signal	4 V max.
S/N ratio	> 110 dB
THD	< 0,005%
Power supply	230 V~/50 Hz/15 VA
Dimensions	482 x 44 x 185 mm, 1 RS
Weight	2.17 kg
Inputs	4 x XLR, bal. 1 x AES/EBU, stereo
Outputs	8 x XLR, bal.
Other features	USB, LAN

### MFE-212

Order No. 0254520



#### Stereo DSP feedback controller

- Prevents acoustic feedback appearing in PA systems
- 12 steep-edged precision notch filters for each stereo channel
- Editable filter parameters (supplied with software)
- 4 factory presets, 16 user presets
- Mono operation or 2-channel operation possible
- AD/DA resolution: 24 bits
- 45 dB attenuation (with gradual reduction in variable mode)

- Optionally continuous signal monitoring (auto notch) or manual setting of the required filters (manual notch)
- Backlit 2 x 20 dot matrix display
- Adjustable input level and output level
- Bypass function
- Clip LED
- Balanced inputs and outputs: XLR and 6.3 mm jack
- USB port (Type-A)
- MIDI input and output
- 482 mm (19") rack installation, 1 RS

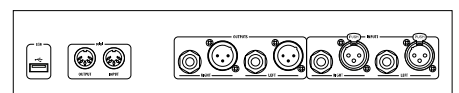
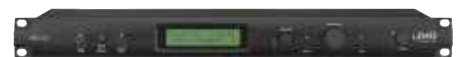

Model	MFE-212
Frequency range	20-20,000 Hz
Input signal	2,2 V max.
Output signal	2,2 V max.
S/N ratio	> 90 dB
THD	< 0,01%
Power supply	~ 230 V/50 Hz/20 VA
Dimensions	482 x 44 x 193 mm, 1 RS
Weight	2 kg



## VU-800/SW

Order No. 0202250



### Audio dB display

- 3-colour LED display with 40 LEDs
- Switchable display mode (dot display or bar graph display)
- Input level control for each channel
- 482 mm (19") rack installation, 1 RS
- Power is provided via enclosed power supply



Model	VU-800/SW
Display	-45 dB to +12 dB
Power supply	via encl. power supply
Dimensions	482 x 45 x 50 mm
Weight	795 g
Power supply	1 x low-voltage jack
Input, stereo	1 x RCA L/R
Output, stereo	1 x RCA L/R

## MEQ-115/SW

Order No. 0244350



### Graphic equalizer

- 2-channel version, 2 x 15 frequency controls in 2/3 octave steps
- Switchable control range  $\pm 6/\pm 12$  dB
- Peak LED
- Switchable low cut filter
- Master volume control
- Bypass switch and ground lift switch
- Frequency controls with centre click
- Inputs and outputs each via 2 x XLR and 2 x 6.3 mm jack



Model	MEQ-115/SW
Frequency range	20-20,000 Hz
Control range	switchable $\pm 6/\pm 12$ dB
Control frequencies	2 x 25/40/63/100/160/250/400/630 Hz/ 1/1.6/2.5/4/6.3/10/16 kHz
Input signal	0,775 V
Input impedance	50 k $\Omega$
Output signal	0,775 V
Output impedance	600 $\Omega$
Low cut	20 Hz/-3 dB
S/N ratio	66 dB
THD	< 0,1%
Power supply	~ 230 V/50 Hz/10 VA
Dimensions	482 x 44,5 x 165 mm, 1 RS
Weight	2,5 kg

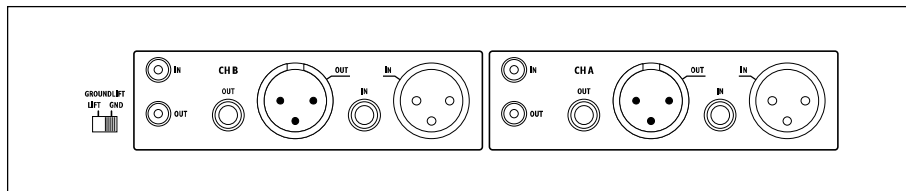

## DEQ-230

Order No. 0254500



### Digital parametric/graphic 2 x 30 band stereo equalizer

- 2 inputs and 2 outputs (XLR, balanced)
- S/PDIF digital input, stereo
- Dynamic range: > 110 dB
- User-defined routing of the inputs to the outputs
- Graphic user interface, PC editing software
- 24 user presets can be stored
- Remote control via USB, RS-485
- Dot matrix display with 2 x 20 characters
- VU meter with 7 LEDs for each channel, optionally for level display or limiter

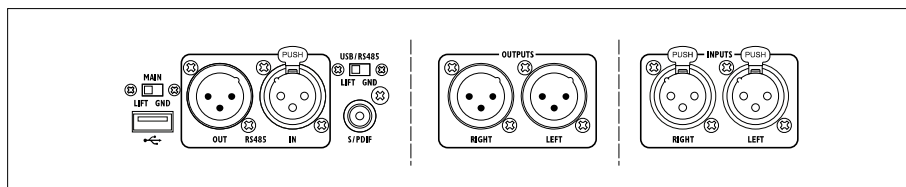

Model	DEQ-230
Frequency range	20-20,000 Hz
S/N ratio	> 110 dB
THD	< 0,005%
Power supply	~ 230 V/50 Hz/42 VA
Dimensions	482 x 44 x 230 mm, 1 RS
Weight	2,84 kg

# Audio Tools

## CD and MP3 Players

### CD-292USB

Order No. 0212790



**Professional dual DJ CD and MP3 player**, with USB 2.0 interface and CDA technology.

- CDA technology allows for both drives to access the same medium
- USB storage media can be connected directly (e.g. USB hard disk, USB flash drive)
- Capable of multi-partition (NTFS, FAT, HFS+)
- Supports ID3 tags and CD text
- Supports play lists (M3U, XML, WPL)
- Anti-shock system (CDDA and MP3 CD)
- Pitch control:  $\pm 8/\pm 16/\pm 100\%$
- Master tempo
- Pitch bending
- Seamless loop/reloop function
- Autoloop
- Loop editing and autoloop editing
- Scratch effect
- Automatic beat counter (switchable to manual)

- Speed search for tracks and folders
- Repeat folder
- Relay play
- Cue function
- 2-way hot cue
- Automatic cue
- Fader start
- Track programming, 99 tracks
- Folder navigation
- Jog dial
- Sleep mode
- Switchable display of the running time of one track as well as the remaining running time of one or all tracks
- 482 mm (19") rack installation
- Audio CD/CD-R/MP3 CD



Model	CD-292USB
Media	CD, MP3, USB
Frequency range	20-20,000 Hz
THD	< 0.1%
Channel separation	> 80 dB
Dynamic range	> 80 dB
S/N ratio	> 80 dB
Output, analogue	2 V
Power supply	~ 230 V/50 Hz/40 VA
Dim., player mech.	482 x 90 x 260 mm, 2 RS
Dim., control panel	482 x 90 x 85 mm, 2 RS
Weight	6.5 kg
Connections	2 x RCA L/R, 2 x 3.5 mm jack (fader start), 2 x cable, 8-pole mini DIN, length: 1.2 m (control connection)

### CD-230USB

Order No. 0212990



**Dual DJ CD and MP3 player**, with USB 2.0 interface and SD/MMC card slot.

- USB flash drives can be connected directly
- For SD/MMC cards up to 32 GB (FAT16/FAT32), available at option
- Anti-shock system
- Seamless loop
- Supports ID3 tags (track display)
- Safe operation due to illuminated rubber buttons
- Pitch control:  $\pm 4/\pm 8/\pm 16\%$
- Pitch bending
- Search for file/track
- Search function via jog dial
- Scratch function
- Repeat function (repeat 1, repeat all)
- 20 tracks can be programmed
- Smallest search step: 1 frame

- Switchable display of the running time of one track as well as the remaining running time of one or all tracks
- Bar graph display
- Quick start (automatic cue)
- 482 mm (19") rack installation
- Audio CD/CD-R/MP3 CD



Model	CD-230USB
Description	Dual DJ CD and MP3 player
Media	CD, MP3, USB, SD, MMC
Frequency range	20-20,000 Hz
THD	< 0.1%
Channel separation	> 80 dB
Dynamic range	> 90 dB
S/N ratio	> 80 dB
Output, analogue	2 V
Power supply	~ 230 V/50 Hz/30 VA
Dim., player mech.	482 x 90 x 270 mm, 2 RS
Dim., control panel	482 x 90 x 100 mm, 2 RS
Weight	5.9 kg
Connections	2 x RCA L/R, 2 x cable, 13-pole mini DIN, length: 1 m (control connection)

### CD-196USB

Order No. 0212890



**Professional DJ CD and MP3 player**, with USB 2.0 interface, anti-shock system and remote control.

- USB storage media can be connected directly (e.g. USB hard disk, USB flash drive)
- Supports multi-partitions FAT16/FAT32, NTFS, HFS+
- Folder navigation
- ID3 tag analysis
- Supports playlists
- Pitch control:  $\pm 8/\pm 16/\pm 100\%$
- Pitch bending
- Master tempo
- Search function via jog dial
- Scratch function
- Title programming for 99 tracks
- Smallest search step: 1 frame
- Automatic or manual beat counter, switchable

- Switchable display of the running time of one track as well as the remaining running time of one or all tracks
- Bar graph display
- Quick start (automatic cue)
- Fader start
- Digital output, coaxial
- 482 mm (19") rack installation
- Supplied with infrared remote control
- Audio CD/CD-R/MP3 CD



Model	CD-196USB
Media	CD, MP3, USB
Frequency range	20-20,000 Hz
THD	< 0.1%
Channel separation	> 75 dB
Dynamic range	> 80 dB
S/N ratio	> 75 dB
Output, analogue	2 V
Output, digital, U <sub>pp</sub>	0.5 V (S/PDIF)
Power supply	~ 230 V/50 Hz/15 VA
Dimensions	482 x 90 x 270 mm, 2 RS
Weight	4.4 kg
Connections	1 x RCA L/R, 1 x RCA (S/PDIF), 1 x 3.5 mm jack (fader start)

## DJP-200USB

Order No. 0211460



### Stereo hi-fi turntable with USB port and integrated phono preamplifier

- USB port (Type-B) for high-quality and convenient digitalisation of analogue vinyl records via PC
- Stereo line output via RCA jacks
- Belt drive
- Magnet system
- Metal pick-up arm and diecast aluminium turntable platter with rubber slipmat
- 2 speeds
- Auto-stop function, switchable
- Smoked acrylic glass cover, removable



Model	DJP-200USB
Turntable platter	Ø 332 mm, diecast aluminium
Speeds	33 $\frac{1}{3}$ /45 rpm
Starting torque	0.3 kg/cm
Wow and flutter	< 0.3%
Power supply	~ 230 V/50 Hz/20 VA
Dimensions	450 x 152 x 352 mm
Weight	3.2 kg
Outputs	1 x RCA L/R USB Type-B jack

## DJP-106SD

Order No. 0212520



### Stereo hi-fi turntable with USB port, SD card slot and integrated phono preamplifier

Simply insert USB storage device or SD card and save track of an album as MP3 file, no PC required.

- USB port (Type-A) for convenient digitalisation of analogue vinyl records
- Recording and reproduction in MP3 format via optional USB storage medium (e.g. USB hard disk, USB flash drive) or SD card
- Automatic level adjustment during recording onto a USB medium
- Supports SD/SDHC cards up to 16 GB, available at option
- Stereo line output via RCA jacks
- Manual track split function
- Belt drive

- Magnet system
- 2 speeds
- Metal pick-up arm and plastic turntable platter with rubber mat
- LCD
- Smoked acrylic glass cover, removable



Model	DJP-106SD
Turntable platter	Ø 298 mm, plastic
Speeds	33 $\frac{1}{3}$ /45 rpm
Starting torque	0.3 kg/cm
Wow and flutter	< 0.25%
Power supply	~ 230 V/50 Hz/10 VA
Dimensions	420 x 115 x 355 mm
Weight	3.3 kg
Outputs	1 x RCA L/R USB Type-A jack

## DJP-104USB

Order No. 0212160



### Stereo hi-fi turntable with USB port and integrated phono preamplifier

- USB port (Type-B) for high-quality and convenient digitalisation of analogue vinyl records via PC, adjustable USB audio level
- Stereo output via RCA jacks, switchable line/phono
- Belt drive with quick start system
- Magnet system
- 2 speeds
- Pitch control:  $\pm 16\%$
- Metal pick-up arm and plastic turntable platter with felt slipmat
- Smoked acrylic glass cover, removable



Model	DJP-104USB
Turntable platter	Ø 298 mm, plastic
Speeds	33 $\frac{1}{3}$ /45 rpm
Pitch control	$\pm 16\%$
Starting torque	0.3 kg/cm
Starting time	< 0.8 s
Wow and flutter	< 0.15%
Rumble	-40 dB unweighted, -55 dB weighted
Power supply	~ 230 V/50 Hz/15 VA
Dimensions	430 x 115 x 350 mm
Weight	2.9 kg
Outputs	1 x RCA L/R USB Type-B jack

# PA Amplifiers

## Analogue Amplifiers

### STA-2200

Order No. 0250490



**Professional stereo PA amplifier**, with integrated crossover network and limiter.

- 2  $\Omega$  stable
- Class H technology with performance-optimised power supply technology
- LCD for indicating temperature, operating mode, protective function
- Integrated crossover network: 120 Hz, 24 dB/oct., selectable: subwoofer, full range or satellite operation
- 3 operating modes can be selected (stereo, parallel or bridged)
- Temperature-controlled fans
- 2 level controls
- Ground lift function
- Speaker switch-on delay
- Protective circuit with LED indication for protection against short circuit, overheating and DC voltage overlay at the outputs

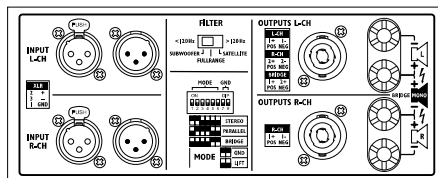

- Each channel with LEDs for indicating operating voltage, level and limiter
- NEUTRIK SPEAKON connections

Model	STA-2200
Peak output power	4,000 W
Power rating at 2 $\Omega$	2 x 750 W
Power rating at 4 $\Omega$	2 x 1,100 W
Power rating at 8 $\Omega$	2 x 700 W
Power rating with 4 $\Omega$ bridged operation	1 x 1,500 W
Power rating with 8 $\Omega$ bridged operation	1 x 2,000 W
Inputs	1 V/20 k $\Omega$
Frequency range	20-20,000 Hz
Crossover frequency	120 Hz
S/N ratio	> 100 dB
Crosstalk attenuation	> 60 dB
THD	< 0.1%
Power supply	~ 230 V/50 Hz/3,600 VA
Dimensions	482 x 88 x 479 mm, 2 RS
Weight	22.5 kg

### STA-2200DSP

Order No. 0259520



**Stereo PA amplifier**, with DSP technology.

- Operating mode (stereo, parallel or bridged), crossover network, delay, compressor and limiter adjustable via DSP
- DSP can be programmed via USB
- Temperature-controlled fans
- 2 level controls
- Ground lift function
- Speaker switch-on delay
- Protective circuit with LED indication for protection against short circuit, overheating and DC voltage overlay at the outputs
- Each channel with LEDs for indicating operating voltage, signal and limiter

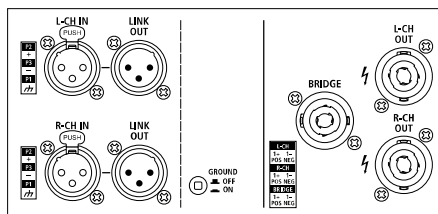

Model	STA-2200DSP
Peak output power	4,000 W
Power rating	2,200 W
Power rating at 4 $\Omega$	2 x 1,200 W
Power rating at 8 $\Omega$	2 x 750 W
Power rating with 8 $\Omega$ bridged operation	1 x 2,200 W
Inputs	1 V/20 k $\Omega$ (bal.) 1 V/10 k $\Omega$ (unbal.)
Frequency range	20-20,000 Hz
S/N ratio	$\geq$ 90 dB
Crosstalk attenuation	> 55 dB
THD	< 0.1%
Power supply	~ 230 V/50 Hz/3,400 VA
Dimensions	483 x 88 x 496 mm, 2 RS
Weight	21 kg

### STA-1600DSP

Order No. 0259510



**Stereo PA amplifier**, with DSP technology.

- Operating mode (stereo, parallel or bridged), crossover network, delay, compressor and limiter adjustable via DSP
- DSP can be programmed via USB
- Temperature-controlled fans
- 2 level controls
- Ground lift function
- Speaker switch-on delay
- Protective circuit with LED indication for protection against short circuit, overheating and DC voltage overlay at the outputs
- Each channel with LEDs for indicating operating voltage, signal and limiter

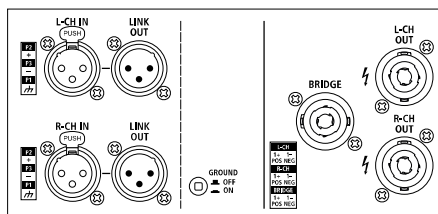

Model	STA-1600DSP
Peak output power	2,700 W
Power rating	1,600 W
Power rating at 4 $\Omega$	2 x 800 W
Power rating at 8 $\Omega$	2 x 500 W
Power rating with 8 $\Omega$ bridged operation	1 x 1,600 W
Inputs	1 V/20 k $\Omega$ (bal.) 1 V/10 k $\Omega$ (unbal.)
Frequency range	20-20,000 Hz
S/N ratio	$\geq$ 90 dB
Crosstalk attenuation	> 55 dB
THD	< 0.1%
Power supply	~ 230 V/50 Hz/2,600 VA
Dimensions	483 x 88 x 430 mm, 2 RS
Weight	16 kg



## STA-3000

Order No. 0250500

482mm  
19" 5500W

**Professional stereo PA amplifier**, with integrated crossover network and limiter.

- 2 Ω stable
- Class H technology with performance-optimised power supply technology
- LCD for indicating temperature, operating mode, protective function
- Integrated crossover network: 120 Hz, 24 dB/oct., switchable subwoofer, full range or satellite operation
- 3 operating modes can be selected (stereo, parallel or bridged)
- Temperature-controlled fans
- 2 level controls
- Ground lift function
- Speaker switch-on delay
- Protective circuit with LED indication for protection against short circuit, overheating and DC voltage overlay at the outputs
- Each channel with LEDs for indicating operating voltage, level and limiter
- NEUTRIK SPEAKON connections
- Supplied with mains cable

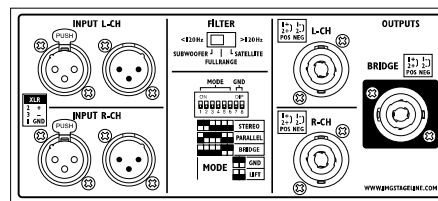

Model	STA-3000
Peak output power	5,500 W
Power rating at 2 Ω	2 x 1,250 W
Power rating at 4 Ω	2 x 1,500 W
Power rating at 8 Ω	2 x 1,000 W
Power rating with 4 Ω bridged operation	1 x 2,500 W
Power rating with 8 Ω bridged operation	1 x 3,000 W
Inputs	1 V/20 kΩ
Frequency range	20-20,000 Hz
Crossover frequency	120 Hz
S/N ratio	> 100 dB
Crosstalk attenuation	> 60 dB
THD	< 0.1%
Power supply	~ 230 V/50 Hz/5,000 VA
Dimensions	482 x 132 x 519 mm, 3 RS
Weight	32 kg

## STA-1400

Order No. 0250480

482mm  
19" 2100W

## STA-1000

Order No. 0250470

482mm  
19" 1600W

## STA-600

Order No. 0250460

482mm  
19" 1000W

**Professional stereo PA amplifiers**, with integrated crossover network and limiter.

- LCD for indicating temperature, operating mode, protective function
- Integrated crossover network: 120 Hz, 24 dB/oct., selectable: subwoofer, full range or satellite operation
- 3 operating modes can be selected (stereo, parallel or bridged)
- Temperature-controlled fans
- 2 level controls
- Ground lift function
- Speaker switch-on delay
- Protective circuit with LED indication for protection against short circuit, overheating and DC voltage overlay at the outputs
- Each channel with LEDs for indicating operating voltage, level and limiter
- NEUTRIK SPEAKON connections



STA-1400, STA-1000 and STA-600 are supplied with 3-pin IEC panel plugs and suitable mains cables.

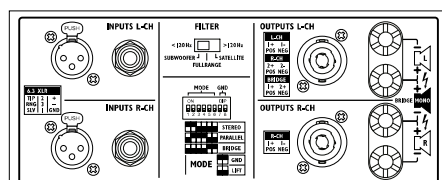

Model	STA-1400	STA-1000	STA-600
Peak output power	2,100 W	1,600 W	1,000 W
Power rating at 4 Ω	2 x 700 W	2 x 500 W	2 x 300 W
Power rating at 8 Ω	2 x 450 W	2 x 350 W	2 x 200 W
Power rating with 8 Ω bridged operation	1 x 1,400 W	1 x 1,000 W	1 x 550 W
Inputs	1 V/20 kΩ	1 V/20 kΩ	1 V/20 kΩ
Frequency range	20-20,000 Hz	20-20,000 Hz	20-20,000 Hz
Crossover frequency	120 Hz	120 Hz	120 Hz
S/N ratio	> 95 dB	> 95 dB	> 95 dB
Crosstalk attenuation	> 60 dB	> 60 dB	> 60 dB
THD	< 0.1%	< 0.1%	< 0.1%
Power supply	~ 230 V/50 Hz/2,300 VA	~ 230 V/50 Hz/1,600 VA	~ 230 V/50 Hz/1,000 VA
Dimensions	482 x 88 x 418 mm, 2 RS	482 x 88 x 418 mm, 2 RS	482 x 88 x 418 mm, 2 RS
Weight	20 kg	15 kg	12.5 kg



# PA Amplifiers

## Analogue Amplifiers

### STA-700

Order No. 0244120



**Stereo PA amplifier**, for general applications.

- Fan cooling
- 2 level controls
- Ground lift switch
- Speaker switch-on delay
- Protective circuit with LED indication for protection against short circuit, overheating and DC voltage overlay at the outputs
- 1 LED per channel for indicating overload (clip)

Model	STA-700
Peak output power	800 W
Power rating at 4 Ω	2 x 275 W
Power rating at 8 Ω	2 x 200 W
Inputs	0.85 V/55 kΩ
Frequency range	10-20,000 Hz
S/N ratio	85 dB
Crosstalk attenuation	> 43 dB
THD	< 0.05%
Power supply	~ 230 V/50 Hz/1,100 VA
Dimensions	482 x 98 x 296 mm, 2 RS
Weight	9.4 kg

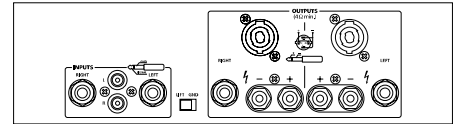

### STA-500

Order No. 0243970



**Stereo PA amplifier**, for general applications.

- Fan cooling
- 2 level controls
- Ground lift switch
- Speaker switch-on delay
- Protective circuit with LED indication for protection against short circuit, overheating and DC voltage overlay at the outputs
- 1 LED per channel for indicating overload (clip)

Model	STA-500
Peak output power	600 W
Power rating at 4 Ω	2 x 200 W
Power rating at 8 Ω	2 x 125 W
Inputs	1.3 V/55 kΩ
Frequency range	10-20,000 Hz
S/N ratio	64 dB
Crosstalk attenuation	> 55 dB
THD	< 0.05%
Power supply	~ 230 V/50 Hz/730 VA
Dimensions	482 x 95 x 300 mm, 2 RS
Weight	6.6 kg

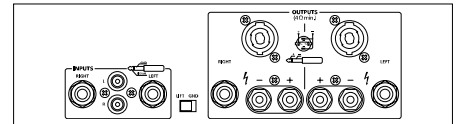

### STA-235

Order No. 0253210



**Stereo PA amplifier**, with integrated limiter.

- LCD for indicating temperature, operating mode, power
- 2 operating modes can be selected (stereo or bridged)
- Limiter function can be activated as required
- Temperature-controlled fans
- 2 level controls
- Ground lift function
- Speaker switch-on delay
- Protective circuit with LED indication for protection against short circuit and overheating
- Each channel with LEDs for indicating overload, level and signal

Model	STA-235
Peak output power	1,400 W
Power rating at 4 Ω	2 x 500 W
Power rating at 8 Ω	2 x 400 W
Power rating with 8 Ω bridged operation	1 x 1,000 W
Inputs	1.2 V/10 kΩ
Frequency range	10-50,000 Hz
S/N ratio	> 80 dB
Crosstalk attenuation	> 50 dB
THD	< 0.1%
Power supply	~ 230 V/50 Hz/2,000 VA
Dimensions	482 x 100 x 330 mm, 2 RS
Weight	11.5 kg

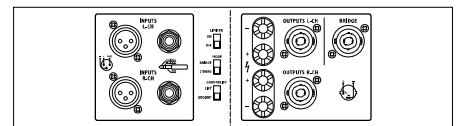

### STA-225

Order No. 0253340



**Stereo PA amplifier, 1,000 W**, with integrated limiter.

- LCD for indicating temperature, operating mode, power
- 2 operating modes can be selected (stereo or bridged)
- Limiter function can be activated as required
- Temperature-controlled fan
- 2 level controls
- Ground lift function
- Speaker switch-on delay
- Protective circuit with LED indication for protection against short circuit and overheating
- Each channel with LEDs for indicating limiter, level and signal

Model	STA-225
Peak output power	1,000 W
Power rating at 4 Ω	2 x 350 W
Power rating at 8 Ω	2 x 250 W
Power rating with 8 Ω bridged operation	1 x 700 W
Inputs	1.3 V/10 kΩ
Frequency range	10-50,000 Hz
S/N ratio	> 80 dB
Crosstalk attenuation	> 50 dB
THD	< 0.1%
Power supply	~ 230 V/50 Hz/1,500 VA
Dimensions	482 x 100 x 330 mm, 2 RS
Weight	10.3 kg

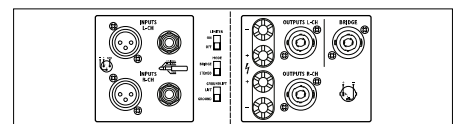

## STA-1500A

Order No. 0259120



**Stereo PA amplifier**, with integrated limiter.

- 3 operating modes can be selected (stereo, parallel or bridged)
- Limiter function can be activated as required
- Temperature-controlled fan
- 2 level controls
- Ground lift function
- Speaker switch-on delay
- Protective circuit with LED indication for protection against short circuit, overheating and DC voltage overlay at the outputs
- Each channel with LEDs for indicating operating voltage, signal and limiter
- NEUTRIK SPEAKON connections

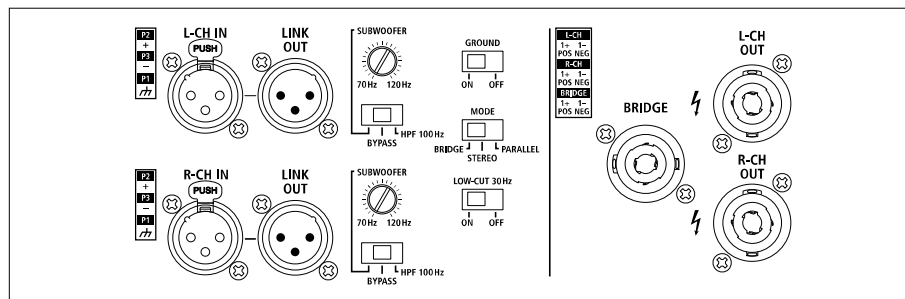

Model	STA-1500A
Peak output power	2,100 W
Power rating at 4 Ω	2 x 700 W
Power rating at 8 Ω	2 x 550 W
Power rating with 8 Ω bridged operation	1 x 1,500 W
Inputs	1 V/10 kΩ
Frequency range	20-20,000 Hz
S/N ratio	77 dB
Crosstalk attenuation	> 60 dB
THD	< 0.1%
Power supply	~ 230 V/50 Hz/2,725 VA
Dimensions	482 x 88 x 430 mm, 2 RS
Weight	15.5 kg

# PA Amplifiers

## Class D PA Amplifiers

### STA-2000D

Order No. 0255220



#### 4-channel class D PA amplifier, 2,400 W

- Class D concept with power amplifier modules from PASCAL
- Excellent acoustic performance
- Extra wide dynamic range with very low THD
- Excellent pulse response also in the bass range
- 482 mm (19") rack installation, 2 RS
- 2 or 4 channels in bridged mode
- 100 V line technique possible in bridged operation
- Silent operation due to temperature-controlled fans, only activated if temperature rises above 85 °C
- Lightweight design due to compact switch-mode power supply



- Energy-efficient concept due to a high efficiency
- 4 level controls
- Protected against short circuit, overtemperature, DC voltage at the output and overload

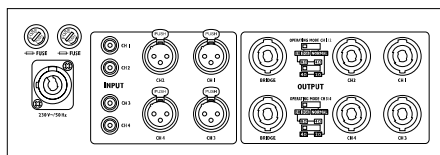

Model	STA-2000D
Peak output power	2,400 W
Power rating at 4 Ω	4 x 500 W
Power rating at 8 Ω	4 x 280 W
Power rating with 4 Ω bridged operation	2 x 1,000 W
Power rating with 8 Ω bridged operation	2 x 1,000 W
Inputs	1 V/10 kΩ (XLR, bal), 1 V/5 kΩ (RCA)
Frequency range	20-20,000 Hz
S/N ratio	> 119 dBA
THD	< 0.05%
Power supply	~ 85-265 V/50 Hz/2,320 VA
Dimensions	482 x 89 x 335 mm, 2 RS
Weight	6.4 kg

### STA-1000D

Order No. 0255210



#### Stereo class D PA amplifier, 1,200 W

- Class D concept with power amplifier modules from PASCAL
- Excellent acoustic performance
- Extra wide dynamic range with very low THD
- Excellent pulse response also in the bass range
- 482 mm (19") rack installation, 2 RS
- Silent operation due to temperature-controlled fans, only activated if temperature rises above 85 °C
- Lightweight design due to compact switch-mode power supply
- Energy-efficient concept due to a high efficiency
- 2 level controls
- Protected against short circuit, overtemperature, DC voltage at the output and overload



- LEDs for indicating power, signal, bridge, overload (clip), overheating and protect
- Bridged operation
- 100 V line technique possible in bridged operation
- Wide mains voltage range: ~ 85-265 V
- NEUTRIK POWERCON and SPEAKON connections

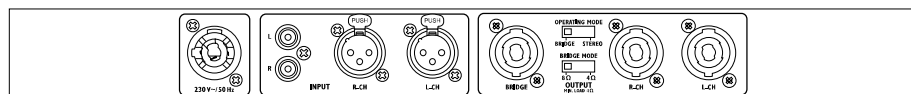

Model	STA-1000D
Peak output power	1,200 W
Power rating at 4 Ω	2 x 500 W
Power rating at 8 Ω	2 x 280 W
Power rating with 4 Ω bridged operation	1 x 1,000 W
Power rating with 8 Ω bridged operation	1 x 1,000 W
Inputs	1 V/10 kΩ (XLR, bal), 1 V/5 kΩ (RCA)
Frequency range	20-20,000 Hz
S/N ratio	> 119 dBA
THD	< 0.05%
Power supply	~ 230 V/50 Hz/1,160 VA
Dimensions	482 x 89 x 335 mm, 2 RS
Weight	5 kg

### STA-800D

Order No. 0255200



#### Stereo class D PA amplifier

- Class D concept with power amplifier modules from HYPEX
- Silent operation due to temperature-controlled fans
- Lightweight design due to compact switch-mode power supply
- Energy-efficient concept due to a high efficiency
- High power reserves due to the application of two switch-mode power supplies



- Powerful bass reproduction due to large buffer capacitors (high power reserves)
- 2 level controls
- Protected against short circuit and overtemperature
- LEDs for indicating power, overload (clip) and protect
- Super slimline design
- NEUTRIK SPEAKON connections

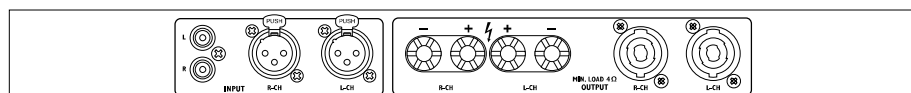

Model	STA-800D
Peak output power	1,000 W
Power rating at 4 Ω	2 x 400 W
Power rating at 8 Ω	2 x 210 W
Inputs	1 V/10 kΩ (XLR, bal), 1 V/4.7 kΩ (RCA)
Frequency range	20-20,000 Hz
S/N ratio	> 110 dBA
THD	< 0.004%
Power supply	~ 230 V/50 Hz/920 VA
Dimensions	482 x 52 x 298 mm, 1 RS
Weight	4 kg

### STA-553D

Order No. 0257350



#### 3-channel class D PA amplifier

- Adjustable crossover frequency for sat and sub
- 3 level controls
- Temperature-controlled fan
- Protective circuit with LED indication for protection against short circuit, overheating and DC voltage overlay at the outputs
- Each channel with LEDs for indicating overload (clip) and signal



Model	STA-553D
Peak output power	600 W
Power rating at 4 Ω	2 x 150 W (satellite) 1 x 250 W (subwoofer)
Power rating at 8 Ω	2 x 100 W (satellite) 1 x 160 W (subwoofer)
Inputs	1.5 V/14 kΩ
Frequency range	20-20,000 Hz
Crossover frequency	50-250 Hz
S/N ratio	> 96 dB
Crosstalk attenuation	> 70 dB
THD	< 0.05%
Power supply	~ 230 V/50 Hz/800 VA
Dimensions	482 x 52 x 290 mm, 1 RS
Weight	4.5 kg

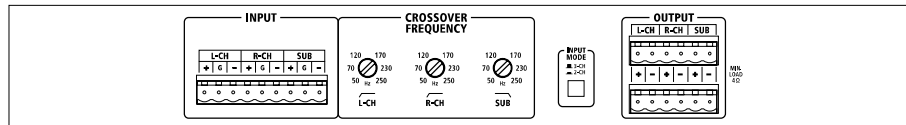

### STA-500D

Order No. 0257340



#### Stereo class D PA amplifier

- 2 operating modes can be selected (stereo or bridged)
- Limiter function can be activated as required
- 2 level controls
- Temperature-controlled fan
- Protective circuit with LED indication for protection

against short circuit, overheating and DC voltage overlay at the outputs

- Each channel with LEDs for indicating overload (clip) and signal



Model	STA-500D
Peak output power	600 W
Power rating at 4 Ω	2 x 250 W
Power rating at 8 Ω	2 x 150 W
Power rating with 8 Ω bridged operation	1 x 500 W
Inputs	1 V/12 kΩ
Frequency range	20-20,000 Hz
S/N ratio	> 96 dB
Crosstalk attenuation	> 70 dB
THD	< 0.05%
Power supply	~ 230 V/50 Hz/840 VA
Dimensions	482 x 52 x 290 mm, 1 RS
Weight	4.4 kg

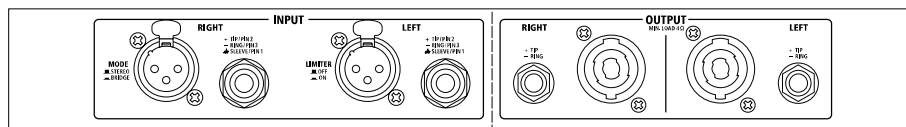

### STA-400D

Order No. 0255190



#### Stereo class D PA amplifier

- Class D concept with power amplifier modules from HYPEx
- Silent operation due to temperature-controlled fans
- Energy-efficient concept due to a high efficiency
- Powerful bass reproduction due to large buffer capacitors (high power reserves)

- 2 level controls
- Protected against short circuit and overtemperature
- LEDs for indicating power, overload (clip) and protect
- NEUTRIK SPEAKON connections



Model	STA-400D
Peak output power	700 W
Power rating at 4 Ω	2 x 270 W
Power rating at 8 Ω	2 x 180 W
Inputs	1 V/10 kΩ (XLR, bal), 1 V/4.7 kΩ (RCA)
Frequency range	20-20,000 Hz
S/N ratio	> 110 dBA
THD	< 0.02%
Power supply	~ 230 V/50 Hz/600 VA
Dimensions	482 x 52 x 277 mm, 1 RS
Weight	3.5 kg

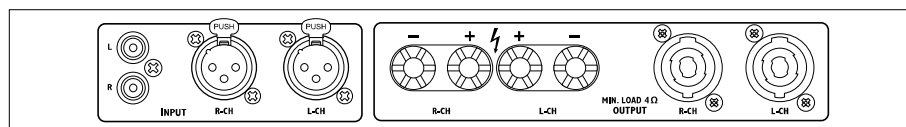

### STA-300D

Order No. 0257330



#### Stereo class D PA amplifier

- 2 operating modes can be selected (stereo or bridged)
- Limiter function can be activated as required
- 2 level controls
- Temperature-controlled fan
- Protective circuit with LED indication for protection

against short circuit, overheating and DC voltage overlay at the outputs

- Each channel with LEDs for indicating overload (clip) and signal



Model	STA-300D
Peak output power	350 W
Power rating at 4 Ω	2 x 150 W
Power rating at 8 Ω	2 x 100 W
Power rating with 8 Ω bridged operation	1 x 300 W
Inputs	1 V/12 kΩ
Frequency range	20-20,000 Hz
S/N ratio	> 96 dB
Crosstalk attenuation	> 70 dB
THD	< 0.05%
Power supply	~ 230 V/50 Hz/510 VA
Dimensions	482 x 52 x 290 mm, 1 RS
Weight	3.7 kg

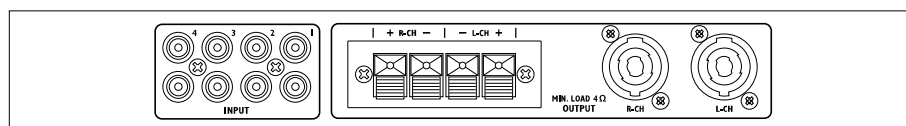

# PA Speaker Systems and Speaker Systems

## PA Speaker Systems

### The C-RAY/8

is a compact active 3-way column PA speaker system with a DSP-controlled 2-channel class D amplifier module and a 4-channel mixer. The system consists of a subwoofer of very high power capability with two 20 cm (8") bass speakers as well as two column modules which are equipped with a total of twelve 7.6 cm (3") full range speakers and two 2.5 cm (1") tweeters. The different connection method and configuration of the column modules allow for an easy and fine tuning with continuously adjustable equalizers via DSP in the inputs. The system provides a powerful sound and is suitable for versatile applications. The components are attached and connected via a twist-and-lock mechanism and therefore do not require any cables. The four inputs can be mixed and parallel out and mix out are also available.

#### C-RAY/8

Order No. 0255630



#### Active column PA speaker system with DSP, 800 W

- Compact full range system with bass-reflex subwoofer and two column modules
- 2 x 20 cm (8") bass speaker, 12 x 7.6 cm (3") full range speaker and 2 x 2.5 cm (1") tweeter in a closed cabinet
- 2-channel class D amplifier system with 2 x 400 W
- DSP-controlled functions for crossover network, equalizer and limiter
- Sound pressure at nominal power: 115 dB, music: 118 dB, peak: 122 dB
- 4-channel mixer
- Continuously adjustable sound characteristics
- Mono selector switch
- Indication of signal, limiter and clip
- Feed-through outputs, rec out and mix output
- High-quality wooden cabinet with protective metal grille
- No cables, components attached via twist-and-lock mechanism
- Supplied w/o protective cover set C-RAY/8BAG, available at option

Model	C-RAY/8
Total output power	800 W
Power rating (RMS)	DSP-controlled 400 W (200+200) bass: 200 W mid-high range: 200 W
Frequency range	50-20,000 Hz
THD	< 0.1%
S/N ratio	80 dB
Input signal	750 mV/22 kΩ (line), 20 mV/2 kΩ (mic, bal), 40 mV/2 kΩ (comb.), 200 mV/22 kΩ (aux)
Number of speakers	16
Sensitivity	95 dB/W/m
Beam angle	hor. 120°, vert. 30°-90° var.
Power supply	~ 230 V/50 Hz/510 VA
Dimensions	250 x 1,730 x 400 mm
Weight	23 kg
Inputs	2 x comb. XLR/6.3 mm (line L/R) 1 x comb. XLR/6.3 mm (mic) 1 x comb. XLR/6.3 mm (combo) 1 x RCA (aux L/R) 1 x 3.5 mm jack (aux L/R)
Outputs	1 x RCA (rec out, L/R) 1 x XLR, par. out 1 x XLR, MIX out



#### C-RAY/8BAG

Order No. 0255690

**Protective cover set**, for C-RAY/8, consisting of a bag for the satellites and a bag for the subwoofer. With carrying handles and shoulder strap.



#### C-RAY/8EXT

Order No. 0255700

**Intermediate piece**, for the C-RAY/8.

- Increases mounting height of column satellite modules by 57 cm
- No cables, components attached via twist-and-lock mechanism
- Dimensions: 85 x 605 x 107 mm
- Weight: 1.34 kg





## VERT-12

Order No. 1000157



### Active column PA speaker system with DSP, 700 W

- Compact full range system with subwoofer and two column modules
- 6 x 7.6 cm (3") bass speaker + 1 x 2.5 cm (1") tweeter in a closed cabinet
- 1 x 30 cm (12") subwoofer in a separate cabinet
- 2-channel class D amplifier system with 300 + 180 W
- DSP-controlled functions for equalizer, limiter and delay
- 4-channel mixer
- 2 x mic/line input, 1 x instrument input (Hi-Z), 1 x stereo line input
- Link and mix outputs
- Bluetooth function for receiving audio files
- High-quality wooden cabinet with protective metal grille
- Wireless plug-in connection of components
- Supplied w/o protective cover set VERT-12BAG, available at option

Model	VERT-12
Total output power	700 W
Power rating (RMS)	DSP-controlled, 480 W (300+180) Bass: 300 W Mid-high range: 180 W
THD	< 0.06% (sub) < 0.09% (sat)
Input signal	400 mV/10 kΩ (line), 7 mV/40 kΩ (mic, bal.), 50 mV/500 kΩ (Hi-Z), 150 mV/15 kΩ (aux)
Number of speakers	8
Sensitivity	98 dB/W/m
Beam angle	hor.: 120°, vert.: 30°
Power supply	~ 230 V/50 Hz/950 VA
Dimensions	117 x 807 x 124 mm (column speaker) 359 x 576 x 432 mm (subwoofer)
Weight	4.7 kg (column speaker) 3.1 kg (intermediate piece) 20 kg (subwoofer)
Inputs	2 x comb. XLR/6.3 mm (mic/line) 1 x 6.3 mm jack (Hi-Z) 1 x RCA (L/R)
Outputs	2 x XLR, link 1 x XLR, MIX out



## VERT-12BAG

Order No. 1000158



**Protective cover set**, for VERT-12, consisting of a bag for the satellites and a bag for the subwoofer. With carrying handles and shoulder strap.



# PA Speaker Systems and Speaker Systems

## PA Speaker Systems

### WAVE-15A

Order No. 0259012



#### Active full range speaker system, 400 W

- Compact 15/2 full range bass-reflex system with plastic cabinet
- 38 cm (15") bass speaker and 25 mm (1") horn tweeter
- Integrated MP3 player with USB/SD slot
- Integrated 5-band equalizer for tone control
- Bluetooth receiver
- Balanced mic input via XLR jack or 6.3 mm jack
- Line input via RCA jack or XLR jack
- 2-way tone control for treble and bass

Model	WAVE-15A
Transmission method	wireless/cable
Total output power	400 W
Power rating (RMS)	250 W
Frequency range	50-20,000 Hz
Input signal	250 mV/7 kΩ (line, XLR, bal.), 150 mV/16 kΩ (line, RCA), 9.5 mV/0.8 kΩ (mic, XLR, bal.), 9.5 mV/0.8 kΩ (mic, 6.3 mm jack)
Sensitivity	95 dB/W/m
Beam angle	H: 90°/V: 60°
Power supply	~ 230 V/50 Hz/410 VA
Dimensions	460 x 710 x 370 mm
Weight	18.6 kg



### WAVE-12A

Order No. 0259011



#### Active full range speaker system, 350 W

- Compact 12/2 full range bass-reflex system with plastic cabinet
- 30 cm (12") bass speaker and 25 mm (1") horn tweeter
- Integrated MP3 player with USB/SD slot
- Integrated 5-band equalizer for tone control
- Bluetooth receiver
- Balanced mic input via XLR jack or 6.3 mm jack
- Line input via RCA jack or XLR jack
- 2-way tone control for treble and bass

Model	WAVE-12A
Transmission method	wireless/cable
Total output power	350 W
Power rating (RMS)	200 W
Frequency range	55-20,000 Hz
Input signal	250 mV/7 kΩ (line, XLR, bal.), 150 mV/16 kΩ (line, RCA), 9.5 mV/0.8 kΩ (mic, XLR, bal.), 9.5 mV/0.8 kΩ (mic, 6.3 mm jack)
Sensitivity	95 dB/W/m
Beam angle	H: 90°/V: 60°
Power supply	~ 230 V/50 Hz/370 VA
Dimensions	390 x 610 x 340 mm
Weight	16 kg



### WAVE-10A

Order No. 0259009



#### Active full range speaker system, 300 W

- Compact 10/2 full range bass-reflex system with plastic cabinet
- 25 cm (10") bass speaker and 25 mm (1") horn tweeter
- Integrated MP3 player with USB/SD slot
- Bluetooth receiver
- Balanced mic input via XLR jack or 6.3 mm jack
- Line input via RCA jack or XLR jack
- 2-way tone control for treble and bass

Model	WAVE-10A
Transmission method	wireless/cable
Total output power	300 W
Power rating (RMS)	150 W
Frequency range	60-20,000 Hz
Input signal	250 mV/7 kΩ (line, XLR, bal.), 150 mV/16 kΩ (line, RCA), 9.5 mV/0.8 kΩ (mic, XLR, bal.), 9.5 mV/0.8 kΩ (mic, 6.3 mm jack)
Sensitivity	95 dB/W/m
Beam angle	H: 90°/V: 60°
Power supply	~ 230 V/50 Hz/270 VA
Dimensions	300 x 510 x 250 mm
Weight	9.4 kg



### WAVE-08A

Order No. 0259008



#### Active full range speaker system, 150 W

- Compact 8/2 full range bass-reflex system with plastic cabinet
- 20 cm (8") bass speaker and 25 mm (1") horn tweeter
- Integrated MP3 player with USB/SD slot
- Bluetooth receiver
- Balanced mic input via XLR jack or 6.3 mm jack
- Line input via RCA jack or XLR jack
- 2-way tone control for treble and bass

Model	WAVE-08A
Transmission method	wireless/cable
Total output power	150 W
Power rating (RMS)	80 W
Frequency range	65-20,000 Hz
Input signal	250 mV/7 kΩ (line, XLR, bal.), 150 mV/16 kΩ (line, RCA), 9.5 mV/0.8 kΩ (mic, XLR, bal.), 9.5 mV/0.8 kΩ (mic, 6.3 mm jack)
Sensitivity	95 dB/W/m
Beam angle	H: 90°/V: 60°
Power supply	~ 230 V/50 Hz/160 VA
Dimensions	260 x 420 x 210 mm
Weight	7.3 kg



## WAVE-15P

Order No. 0259016



### Passive full range speaker system, 500 W, 8 Ω

- Full range bass-reflex system
- Robust plastic cabinet
- 38 cm (15") bass speaker with steel basket
- 25 mm (1") horn tweeter, 34 mm (1 3/8") voice coil diameter
- PTC tweeter protection
- M8 threaded inserts at the top and bottom
- 2 x SPEAKER jack, in/out
- Stand sleeve

Model	WAVE-15P
Total power rating	500 W
Power rating (RMS)	250 W
Impedance	8 Ω
Frequency range	55-20,000 Hz
Sensitivity	96 dB/W/m
Beam angle	H: 90°/V: 60°
Dimensions	460 x 710 x 370 mm
Weight	15.8 kg



## WAVE-12P

Order No. 0259015



### Passive full range speaker system, 400 W, 8 Ω

- Full range bass-reflex system
- Robust plastic cabinet
- 30 cm (12") bass speaker with steel basket
- 25 mm (1") horn tweeter, 34 mm (1 3/8") voice coil diameter
- PTC tweeter protection
- M8 threaded inserts at the top and bottom
- 2 x SPEAKER jack, in/out
- Stand sleeve

Model	WAVE-12P
Total power rating	400 W
Power rating (RMS)	200 W
Impedance	8 Ω
Frequency range	55-20,000 Hz
Sensitivity	95 dB/W/m
Beam angle	H: 90°/V: 60°
Dimensions	390 x 610 x 340 mm
Weight	13.6 kg



## WAVE-10P

Order No. 0259014



### Passive full range speaker system, 300 W, 8 Ω

- Full range bass-reflex system
- Robust plastic cabinet
- 25 cm (10") bass speaker with steel basket
- 25 mm (1") horn tweeter, 25 mm (1") voice coil diameter
- PTC tweeter protection
- M8 threaded inserts at the top and bottom
- 2 x SPEAKER jack, in/out
- Stand sleeve

Model	WAVE-10P
Total power rating	300 W
Power rating (RMS)	150 W
Impedance	8 Ω
Frequency range	60-20,000 Hz
Sensitivity	95 dB/W/m
Beam angle	H: 90°/V: 60°
Dimensions	300 x 510 x 210 mm
Weight	7.5 kg



## WAVE-08P

Order No. 0259013



### Passive full range speaker system, 200 W, 8 Ω

- Full range bass-reflex system
- Robust plastic cabinet
- 20 cm (8") bass speaker with steel basket
- 25 mm (1") horn tweeter, 25 mm (1") voice coil diameter
- PTC tweeter protection
- M8 threaded inserts at the top and bottom
- 2 x SPEAKER jack, in/out
- Stand sleeve

Model	WAVE-08P
Total power rating	200 W
Power rating (RMS)	100 W
Impedance	8 Ω
Frequency range	65-20,000 Hz
Sensitivity	95 dB/W/m
Beam angle	H: 90°/V: 60°
Dimensions	260 x 420 x 210 mm
Weight	5.8 kg



# PA Speaker Systems and Speaker Systems

## PA Speaker Systems

### PAK-415

Order No. 0256050



#### Active power PA speaker system with 2-channel amplifier, 700 W

- Compact 15/2 full range system with robust plastic cabinet
- Modern amplifier system (bass: class D, tweeter: class A/B)
- Sound pressure at nominal power: 124 dB
- 4 selectable presets: normal, hi-fi, DJ and voice, switchable high-pass filter: 75 Hz
- MIC/LINE input, switchable



Model	PAK-415
Total output power	700 W
Power rating (RMS)	450 (350+100) W
Frequency range	40-20,000 Hz
Input signal	260 mV/10 kΩ (line), 2 mV/10 kΩ (mic)
Sensitivity	98 dB/W/m
Power supply	~ 230 V/50 Hz/550 VA
Dimensions	455 x 740 x 390 mm
Weight	18.7 kg
Inputs	1 x comb. XLR/6.3 mm (line/mic)
Outputs	1 x XLR, par. out

### PAK-412

Order No. 0256040



#### Active power PA speaker system with 2-channel amplifier, 700 W

- Compact 12/2 full range system with robust plastic cabinet
- Modern amplifier system (bass: class D, tweeter: class A/B)
- Sound pressure at nominal power: 124 dB
- 4 selectable presets: normal, hi-fi, DJ and voice, switchable high-pass filter: 75 Hz
- Mic/line input, switchable



Model	PAK-412
Total output power	700 W
Power rating (RMS)	450 (350+100) W
Frequency range	40-20,000 Hz
Input signal	260 mV/10 kΩ (line), 2 mV/10 kΩ (mic)
Sensitivity	98 dB/W/m
Power supply	~ 230 V/50 Hz/500 VA
Dimensions	405 x 670 x 340 mm
Weight	17.3 kg
Inputs	1 x comb. XLR/6.3 mm (line/mic)
Outputs	1 x XLR, par. out

### PAK-410

Order No. 0256030



#### Active power PA speaker system with 2-channel amplifier, 500 W

- Compact 10/2 full range system with robust plastic cabinet
- Modern amplifier system (bass: class D, tweeter: class A/B)
- Sound pressure at nominal power: 121 dB
- 4 selectable presets: normal, hi-fi, DJ and voice, switchable high-pass filter: 75 Hz
- Mic/line input, switchable



Model	PAK-410
Total output power	500 W
Power rating (RMS)	300 (250+50) W
Frequency range	55-20,000 Hz
Input signal	260 mV/10 kΩ (line), 2 mV/10 kΩ (mic)
Sensitivity	97 dB/W/m
Power supply	~ 230 V/50 Hz/400 VA
Dimensions	340 x 560 x 290 mm
Weight	12 kg
Inputs	1 x comb. XLR/6.3 mm (line/mic)
Outputs	1 x XLR, par. out

### PAK-15DMP

Order No. 0255840



#### Active DJ and power speaker system, 200 W

- 15/2 full range bass-reflex system with plastic cabinet
- 38 cm (15") bass speaker and 25 mm (1") horn tweeter
- Integrated MP3 player with USB/SD slot and FM radio
- Bluetooth receiver
- Infrared remote control
- Stand sleeve



Model	PAK-15DMP
Total output power	200 W
Power rating (RMS)	120 W
Frequency range	45-20,000 Hz
Input signal	600 mV/8 kΩ (line, XLR, bal.), 500 mV/8 kΩ (line, RCA/3.5 mm jack), 30 mV/1 kΩ (mic, XLR, bal.), 75 mV/2 kΩ (mic, 6.3 mm jack)
Sensitivity	96 dB/W/m
Power supply	~ 230 V/50 Hz/220 VA
Dimensions	445 x 700 x 360 mm
Weight	13 kg
Inputs	XLR, RCA L/R or 3.5 mm jack (line), XLR or 6.3 mm jack (mic)
Outputs	XLR, bal. (mix out)

### PAK-12DMP

Order No. 0255830



#### Active DJ and power speaker system, 180 W

- Compact 12/2 full range bass-reflex system with plastic cabinet
- 30 cm (12") bass speaker and 25 mm (1") horn tweeter
- Integrated MP3 player with USB/SD slot and FM radio
- Bluetooth receiver
- Infrared remote control
- Stand sleeve



Model	PAK-12DMP
Total output power	180 W
Power rating (RMS)	90 W
Frequency range	50-20,000 Hz
Input signal	460 mV/8 kΩ (line, XLR, bal.), 500 mV/8 kΩ (line, RCA/3.5 mm jack), 12 mV/2 kΩ (mic, XLR, bal.), 30 mV/4 kΩ (mic, 6.3 mm jack)
Sensitivity	94 dB/W/m
Power supply	~ 230 V/50 Hz/200 VA
Dimensions	370 x 590 x 290 mm
Weight	11.2 kg
Inputs	XLR, RCA L/R or 3.5 mm jack (line), XLR or 6.3 mm jack (mic)
Outputs	XLR, bal. (mix out)

### PAK-10DMP

Order No. 0255820



#### Active DJ and power speaker system, 150 W

- Compact 10/2 full range bass-reflex system with plastic cabinet
- 25 cm (10") bass speaker and 25 mm (1") horn tweeter
- Integrated MP3 player with USB/SD slot and FM radio
- Bluetooth receiver
- Infrared remote control
- Line input via RCA or 3.5 mm jack
- Stand sleeve



Model	PAK-10DMP
Total output power	150 W
Power rating (RMS)	80 W
Frequency range	55-20,000 Hz
Input signal	470 mV/10 kΩ (line, XLR, bal.), 1 V/20 kΩ (line, 6.3 mm jack), 500 mV/50 kΩ (line, RCA/3.5 mm jack), 25 mV/10 kΩ (mic, XLR, bal.), 65 mV/20 kΩ (mic, 6.3 mm jack)
Sensitivity	93 dB/W/m
Power supply	~ 230 V/50 Hz/170 VA
Dimensions	320 x 490 x 250 mm
Weight	8 kg
Inputs	XLR or 6.3 mm jack (line) RCA L/R or 3.5 mm jack (line) XLR or 6.3 mm jack (mic)
Outputs	XLR, bal. (mix out)

### PAK-8DMP

Order No. 0255850



#### Active DJ and power speaker system, 120 W

- Compact 8/2 full range bass-reflex system with plastic cabinet
- 20 cm (8") bass speaker and 25 mm (1") horn tweeter
- Integrated MP3 player with USB/SD slot and FM radio
- Bluetooth receiver
- Infrared remote control
- Line input via RCA or 3.5 mm jack
- Stand sleeve



Model	PAK-8DMP
Total output power	120 W
Power rating (RMS)	60 W
Frequency range	60-20,000 Hz
Input signal	300 mV/10 kΩ (line, XLR, bal.), 730 mV/20 kΩ (line, 6.3 mm jack), 450 mV/48 kΩ (line, RCA/3.5 mm jack), 20 mV/10 kΩ (mic, XLR, bal.), 50 mV/20 kΩ (mic, 6.3 mm jack)
Sensitivity	93 dB/W/m
Power supply	~ 230 V/50 Hz/140 VA
Dimensions	240 x 390 x 200 mm
Weight	5.8 kg
Inputs	XLR or 6.3 mm jack (line) RCA L/R or 3.5 mm jack (line) XLR or 6.3 mm jack (mic)
Outputs	XLR, bal. (mix out)



# PA Speaker Systems and Speaker Systems

## PA Speaker Systems

### PAB-515/BL

Order No. 0248250



#### Professional PA speaker system, 600 W, 8 Ω

- Full range system of high power capability and of very high efficiency
- Robust plastic cabinet
- 38 cm (15") bass speaker with diecast aluminium basket and coated cone
- 25 mm (1", 44 mm voice coil) horn tweeter
- Bass-reflex system
- High-quality crossover network
- Multi-purpose positioning and installation options
- M8 threaded inserts at the top and bottom
- 2 x NEUTRIK SPEAKON terminal, in/out
- Stand sleeve and ergonomic carrying handle

Model	PAB-515/BL
Total power rating	600 W
Power rating (RMS)	300 W
Impedance	8 Ω
Frequency range	45-18,500 Hz
Sensitivity	102 dB/W/m
Dimensions	450 x 670 x 345 mm
Weight	23 kg
Inputs	1 x NEUTRIK SPEAKON
Outputs	1 x NEUTRIK SPEAKON
	par. out



### PAB-512/BL

Order No. 0248240



#### Professional PA speaker system, 500 W, 8 Ω

- Full range system of high power capability and of very high efficiency
- Robust plastic cabinet
- 30 cm (12") bass speaker with diecast aluminium basket and coated cone
- 25 mm (1", 44 mm voice coil) horn tweeter
- Bass-reflex system
- High-quality crossover network
- Multi-purpose positioning and installation options
- M8 threaded inserts at the top and bottom
- 2 x NEUTRIK SPEAKON terminal, in/out
- Stand sleeve and ergonomic carrying handle

Model	PAB-512/BL
Total power rating	500 W
Power rating (RMS)	250 W
Impedance	8 Ω
Frequency range	55-18,500 Hz
Sensitivity	102 dB/W/m
Dimensions	395 x 590 x 300 mm
Weight	18 kg
Inputs	1 x NEUTRIK SPEAKON
Outputs	1 x NEUTRIK SPEAKON, par. out



### PAB-515BAG

Order No. 0251350

### PAB-512BAG

Order No. 0251340

#### Protective covers for speaker systems

##### PAB-515BAG for professional speaker system

##### PAB-515/BL

##### PAB-512BAG for professional speaker system

##### PAB-512/BL

- Robust synthetic cloth on the outside with soft inner lining
- The cover can stay on during operation!
- Openings for cables, stand and handle; cover straps to be closed with hook and loop fastener or zip fastener
- Including plastic padding for the handle bar of the speaker system



## PAB-215MK2

Order No. 0253850

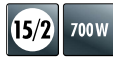

### High-power PA and DJ speaker system, 700 W, 8 Ω

- Full range system of a very high efficiency
- Cabinet made of a combination of MDF wood and plywood
- 38 cm (15") bass speaker with diecast aluminium basket
- 25 mm (1", 44 mm voice coil) horn tweeter
- Bass-reflex system
- High-quality crossover network
- Multi-purpose positioning and installation options
- M8 threaded inserts for suspended installation
- 2 x NEUTRIK SPEAKON terminal, in/out
- Stand sleeve and carrying handles

Model	PAB-215MK2
Total power rating	700 W
Power rating (RMS)	350 W
Impedance	8 Ω
Frequency range	45-20,000 Hz
Sensitivity	99 dB/W/m
Dimensions	470 x 770 x 440 mm
Weight	31.8 kg
Inputs	1 x NEUTRIK SPEAKON
Outputs	1 x NEUTRIK SPEAKON par. out



## PAB-212MK2

Order No. 0253840



### High-power PA and DJ speaker system, 500 W, 8 Ω

- Full range system of a very high efficiency
- Cabinet made of a combination of MDF wood and plywood
- 30 cm (12") bass speaker with diecast aluminium basket
- 25 mm (1", 44 mm voice coil) horn tweeter
- Bass-reflex system
- High-quality crossover network
- Multi-purpose positioning and installation options
- M8 threaded inserts for suspended installation
- 2 x NEUTRIK SPEAKON terminal, in/out
- Stand sleeve and carrying handles

Model	PAB-212MK2
Total power rating	500 W
Power rating (RMS)	250 W
Impedance	8 Ω
Frequency range	50-20,000 Hz
Sensitivity	98 dB/W/m
Dimensions	380 x 630 x 350 mm
Weight	22.4 kg
Inputs	1 x NEUTRIK SPEAKON
Outputs	1 x NEUTRIK SPEAKON par. out



## PAB-210MK2

Order No. 0253830



### High-power PA and DJ speaker system, 400 W, 8 Ω

- Full range system of a very high efficiency
- Cabinet made of a combination of MDF wood and plywood
- 25 cm (10") bass speaker with diecast aluminium basket
- 25 mm (1", 34 mm voice coil) horn tweeter
- Bass-reflex system
- High-quality crossover network
- Multi-purpose positioning and installation options
- M8 threaded inserts for suspended installation
- 2 x NEUTRIK SPEAKON terminal, in/out
- Stand sleeve

Model	PAB-210MK2
Total power rating	400 W
Power rating (RMS)	200 W
Impedance	8 Ω
Frequency range	65-20,000 Hz
Sensitivity	97 dB/W/m
Dimensions	330 x 520 x 300 mm
Weight	16.18 kg
Inputs	1 x NEUTRIK SPEAKON
Outputs	1 x NEUTRIK SPEAKON, par. out



# PA Speaker Systems and Speaker Systems

## PA Monitor Speaker Systems

### FLAT-M200

Order No. 0259876



#### Active PA stage monitor speaker system, 300 W

- Flat and very compact full range system
- Fitted with 4 x 10 cm (FaitalPRO, 4 x 4") full range speaker with neodymium magnets
- Class D amplifier system
- Sound pressure at nominal power: 122 dB
- Indication of signal and limiter
- Volume control and tone control
- Balanced line/mic input and feed-through output
- High-quality multiplex wooden cabinet with protective metal grille
- 2 x M10 and 2 x M6 threaded inserts for stand adapter or mounting device
- Supplied with clamp for mounting, e.g. onto a microphone stand

Model	FLAT-M200
Total output power	300 W
Power rating (RMS)	200 W
Frequency range	70-20,000 Hz
Input signal	25 mV/28 kΩ (line, bal), 6 mV/20 kΩ (mic, bal)
Sensitivity	98 dB/W/m
Power supply	~ 230 V/50 Hz/356 VA
Dimensions	320 x 150 x 250 mm
Weight	4.11 kg
Inputs	1 x comb. XLR/6.3 mm (line/mic)
Outputs	1 x XLR link out



### FLAT-M200BAG

Order No. 0179260

#### Transport and protective bag

- Suitable for active PA stage monitor speaker system FLAT-M200
- Black, partly padded nylon version with zip fastener
- Carrying handle, rubber feet and lateral cable bag



### FLAT-M100

Order No. 0259590



#### Active PA stage monitor speaker system, 200 W

- Flat and very compact full range system
- Fitted with 2 x 10 cm (FaitalPRO, 2 x 4") full range speaker with neodymium magnets
- Class D amplifier system
- Sound pressure at nominal power: 116 dB
- Indication of signal and limiter
- Volume control and tone control
- Balanced line/mic input and feed-through output
- High-quality multiplex wooden cabinet with protective metal grille
- 2 x M10 and 2 x M6 threaded inserts for stand adapter or mounting device
- Supplied with clamp for mounting, e.g. onto a microphone stand

Model	FLAT-M100
Total output power	200 W
Power rating (RMS)	100 W
Frequency range	90-20,000 Hz
Input signal	16 mV/28 kΩ (line, bal), 5 mV/20 kΩ (mic, bal)
Sensitivity	97 dB/W/m
Power supply	~ 230 V/50 Hz/175 VA
Dimensions	265 x 120 x 192.5 mm
Weight	2.4 kg
Inputs	1 x comb. XLR/6.3 mm (line/mic)
Outputs	1 x XLR link out



### FLAT-M100BAG

Order No. 0179030

#### Transport and protective bag

- Suitable for active PA stage monitor speaker system FLAT-M100
- Black, partly padded nylon version with zip fastener
- Carrying handle, rubber feet and lateral cable bag



### PAK-312M/SW

Order No. 0257170



#### Universal active PA speaker system with DSP, 500 W

- Compact 12/2 full range bass-reflex system
- 30 cm (12") coaxial speaker system with 25 mm (1", 44 mm voice coil) horn tweeter
- DSP-controlled 2-channel amplifier system, bass: class D, tweeter: analogue
- 3 selectable presets: music, flat and low cut (120 Hz)
- High-quality cabinet made of multiplex wood with protective metal grille
- Integrated stand sleeve for multi-purpose positioning

Model	PAK-312M/SW
Power rating (RMS)	DSP-controlled, 370 W (300+70) bass: 300 W tweeter: 70 W
Frequency range	50-20,000 Hz
Input signal	500 mV/20 kΩ (line, bal.), 7 mV/1 kΩ (mic, bal.)
Sensitivity	98 dB/W/m
Power supply	~ 230 V/50 Hz/510 VA
Dimensions	480 x 380 x 500 mm
Weight	19 kg
Inputs	2 x comb. XLR/6.3 mm (line/mic A, line B)
Outputs	2 x XLR, par. out, 1 x XLR MIX out



### PAK-308M/SW

Order No. 0255110



#### Universal active PA speaker system with DSP, 500 W

- Compact 8/2 full range bass-reflex system
- 20 cm (8") coaxial speaker system with 25 mm (1", 44 mm voice coil) horn tweeter
- DSP-controlled 2-channel amplifier system, bass: class D, tweeter: analogue
- 3 selectable presets: music, flat and low cut
- High-quality cabinet made of multiplex wood with protective metal grille
- Supplied with mounting bracket and integrated stand sleeve

Model	PAK-308M/SW
Power rating (RMS)	DSP-controlled, 370 W (300+70) bass: 300 W tweeter: 70 W
Frequency range	60-20,000 Hz
Input signal	775 mV/20 kΩ (line, bal.), 10 mV/20 kΩ (mic, bal.)
Sensitivity	97 dB/W/m
Power supply	~ 230 V/50 Hz/350 VA
Dimensions	340 x 303 x 379 mm
Weight	10.75 kg
Inputs	2 x comb. XLR/6.3 mm (line/mic A, line B)
Outputs	2 x XLR, par. out, 1 x XLR MIX out



### PAB-308M/SW

Order No. 0255100



#### Universal PA speaker system, 300 W, 8 Ω

- Compact 8/2 full range bass-reflex system
- 20 cm (8") coaxial speaker system with 25 mm (1", 44 mm voice coil) horn tweeter
- High-quality cabinet made of birch plywood with metal protective grille
- Multi-purpose positioning and installation options, especially as a floor monitor
- Supplied with mounting bracket and integrated stand sleeve
- NEUTRIK SPEAKON terminal

Model	PAB-308M/SW
Total power rating	300 W
Power rating (RMS)	150 W
Impedance	8 Ω
Frequency range	80-20,000 Hz
Sensitivity	96 dB/W/m
Dimensions	340 x 303 x 379 mm
Weight	10 kg
Inputs	1 x NEUTRIK SPEAKON
Outputs	1 x NEUTRIK SPEAKON, par. out



# PA Speaker Systems and Speaker Systems

## PA Subwoofers

### PSUB-12AKA

Order No. 0254310



#### Active 2.1 PA subwoofer, 1,200 W

- Active bass-reflex subwoofer system with wooden cabinet
- Integrated 2.1 active module
- Power rating: SUB: 500 W, SAT: 2 x 150 W
- 30 cm (12") bass speaker of high power capability and long excursion
- Stereo line + mic input with gain control
- Adjustable crossover frequency: 80-250 Hz
- 2-way tone control for bass and treble, balance
- Integrated limiter, clipping display
- High-quality workmanship, integrated carrying handles
- Metal front grille, stand sleeve, rubber feet

Model	PSUB-12AKA
Total output power	1,200 W
Power rating (RMS)	500 W (SUB), 2 x 150 W (SAT)
Frequency range	30-250 Hz
S/N ratio	> 74 dB
Input signal	880 mV-7 V (line) 30 mV (mic)
Power supply	~ 230 V/50 Hz/1,870 VA
Dimensions	460 x 380 x 455 mm
Weight	28 kg
Inputs	XLR L/R, bal. RCA L/R, unbal. 6.3 mm jack, unbal.
Outputs	RCA L/R NEUTRIK SPEAKON L/R (sat: > 150 Hz)



### PSUB-15AKA

Order No. 0254320



#### Active 2.1 PA subwoofer, 1,200 W

- Active bass-reflex subwoofer system with wooden cabinet
- Integrated 2.1 active module
- Power rating: SUB: 500 W, SAT: 2 x 150 W
- 38 cm (15") bass speaker of high power capability and long excursion
- Stereo line input and mic input with gain control
- Adjustable crossover frequency: 80-250 Hz
- 2-way tone control for bass and treble, balance
- Integrated limiter, clipping indication
- High-quality workmanship, integrated carrying handles
- Metal front grille, stand sleeve, rubber feet

Model	PSUB-15AKA
Total output power	1,200 W
Power rating (RMS)	500 W (SUB), 2 x 150 W (SAT)
Frequency range	30-250 Hz
S/N ratio	> 74 dB
Input signal	880 mV-7 V (line) 30 mV (mic)
Power supply	~ 230 V/50 Hz/1,870 VA
Dimensions	600 x 500 x 580 mm
Weight	44 kg
Inputs	XLR L/R, bal. RCA L/R, unbal. 6.3 mm jack, unbal.
Outputs	RCA L/R NEUTRIK SPEAKON L/R (sat: > 150 Hz)



### PSUB-18L

Order No. 0250420



#### Professional active subwoofer system, 800 W

- Professional high-performance subwoofer
- Band-pass cabinet with black textured coating
- Double ventilation
- 46 cm (18") bass speaker of long excursion
- High-power amplifier section with integrated limiter
- Fixed subsonic filter (25 Hz), gain control and variable active low-pass filter
- Phase reversal switch as well as various protective circuits
- Lateral carrying handles

Model	PSUB-18L
Total output power	800 W
Power rating (RMS)	400 W
Frequency range	35-150 Hz
Input signal	300 mV/20 kΩ (bal. line in)
Sensitivity	99 dB/W/m
Power supply	~ 230 V/50 Hz/1,000 VA
Dimensions	695 x 530 x 580 mm
Weight	46 kg
Inputs	input: XLR par. output: XLR

- Stand sleeve at the top
- Extra powerful sound with a good low limit frequency
- Excellent efficiency



### PSUB-418AK

Order No. 0256060



#### Active power PA subwoofer, 1,000 W

- Compact and lightweight 46 cm (18") subwoofer with class D amplifier
- Cabinet made of birch plywood with stand sleeve, carrying handles and castors
- Bass-reflex system with sound pressure at nominal power: 127 dB
- Adjustable crossover frequency: 60-150 Hz, gain control, phase reversal switch
- Balanced inputs: comb. XLR/6.3 mm and parallel XLR outputs

Model	PSUB-418AK
Total output power	1,000 W
Power rating (RMS)	600 W
Frequency range	35-150 Hz
Input signal	1.5 V/55 kΩ
Sensitivity	97 dB/W/m
Power supply	~ 230 V/50 Hz/840 VA
Dimensions	560 x 660 x 600 mm (w/o castors)
Weight	38 kg
Inputs	comb. XLR/6.3 mm input (L/R)
Outputs	XLR: par. out (L/R)





## MEGA-118SUB

Order No. 0090080



### Premium professional PA cabinet subwoofer, 2,000 W, 8 Ω

- Subwoofer system
- Cabinet made of birch plywood
- Durable 2-component PU coating
- 46 cm (18", Faital) high-performance bass speaker with diecast aluminium basket
- Bass-reflex system
- 2 x NEUTRIK SPEAKON terminal, in/out
- Mounting holes for mounting optional castors
- M20 mounting plate (recommended distance tube: KM-21367, available at option)

Model	MEGA-118SUB
Total power rating	2,000 W
Power rating (RMS)	1,000 W
Impedance	8 Ω
Frequency range	30-200 Hz
Sensitivity	97 dB/W/m
Dimensions	700 x 570 x 590 mm
Weight	46 kg
Inputs	1 x NEUTRIK SPEAKON
Outputs	1 x NEUTRIK SPEAKON



## MEGA-118SUBAK

Order No. 0090090



### Premium professional active PA cabinet subwoofer, 1,500 W

- High-power active bass-reflex subwoofer system
- 46 cm (18", Faital) high-performance bass speaker
- Digital amplifier with high power reserves
- Cabinet made of high-quality and extensively reinforced premium birch plywood
- Durable two-component PU coating
- M20 mounting plate (recommended distance tube: KM-21367, available at option)

Model	MEGA-118SUBAK
Total output power	1,500 W
Power rating (RMS)	1,000 W
Frequency range	30-250 Hz
Input signal	480 mV/17 kΩ (XLR/6.3 mm, bal.)
Sensitivity	97 dB/W/m
Power supply	~ 230 V/50 Hz/3,050 VA
Dimensions	700 x 570 x 590 mm
Weight	51 kg
Inputs	comb. XLR/6.3 mm input L/R
Outputs	XLR: par. out L/R XLR: high-pass out L/R XLR: low-pass out NEUTRIK SPEAKON



## MEGA-215SUB

Order No. 0090100



### Premium professional PA cabinet subwoofer, 4,000 W, 4 Ω

- High-power bass-reflex hybrid horn subwoofer system
- 2 x 38 cm (15", Faital) high-performance bass speaker
- Cabinet made of high-quality and extensively reinforced birch multiplex
- Durable and high-strength two-component PU coating
- Front grille with acoustic foam
- Transport cover for covering the front of the speaker cabinet

Model	MEGA-215SUB
Total power rating	4,000 W
Power rating (RMS)	2,000 W
Impedance	4 Ω
Frequency range	30-250 Hz
Sensitivity	98 dB/W/m
Dimensions	1,050 x 500 x 650 mm (w/o castors)
Weight	63 kg
Inputs	1 x NEUTRIK SPEAKON
Outputs	1 x NEUTRIK SPEAKON



## MEGA-215DSP

Order No. 0090110



### Premium professional active PA subwoofer with DSP, 2,400 W

- High-power active bass-reflex hybrid horn subwoofer system
- 2 x 38 cm (2 x 15", Faital) high-performance bass speaker
- 2 x PASCAL-S-PRO2 power amplifier modules in bridge circuit
- 3-channel DSP, adjustments via Ethernet or USB, to be programmed as required via DSP control software or app

Model	MEGA-215DSP
Total output power	2,400 W
Power rating (RMS)	2,000 W
Frequency range	35-300 Hz
Input signal	XLR, bal. line, L/R
Sensitivity	98 dB/W/m
Power supply	~ 230 V/50 Hz/2,400 VA
Dimensions	1,050 x 500 x 650 mm
Weight	69 kg
Inputs	XLR: input L/R
Outputs	XLR: par. out L/R XLR: DSP out L/R



# PA Speaker Systems and Speaker Systems

## PA Speaker Systems

### L-RAY/1000

Order No. 0252090



#### Professional PA speaker array (controlled by DSP software), active, 1,000 W

Compact array of high power capability with 4 mid-high range speaker units and a dual bass module, each section with its own 350 W power amplifier and controlling software (the configuration of the system is supported by a PC, but it operates as a stand-alone unit). Supplied with extensive and variable equipment for suspended mounting systems (Flyware). The mid-high range systems are each equipped with 2 x 10 cm (4") high-performance speakers and a magnetostatic speaker for a perfect reproduction rich in detail. The dynamic characteristics are absolutely convincing, at the same time the tonality at the basic setting is very pleasant. Despite its compact size, the bass module with 2 x 20 cm (8") bass speaker provides an amazingly deep bass reproduction and a high level stability which is only possible by using special bass speakers of very high power capability and the comprehensive DSP optimisation. The software allows the following adjustments (min. system requirement is a Windows PC only, WIN98 or higher, with CD drive and interface):

- Parametric equalizer (6 bands)
- Filters (high-pass or low-pass up to 36 dB/oct. with various characteristics)
- Level
- Compression and limiting
- Delay

Up to 10 L-RAY systems can be addressed via one RS-485 data bus. With the optional USB/RS-485 converter DA-70157, it is possible to connect a PC or laptop with USB interface to the serial RS-485 interface.

On delivery, the software of the system is matched to a perfect base linearity and can be used immediately. Otherwise, the software adjustments are extremely easy to do and sound engineers can even operate it intuitively.

The system is supplied with a robust mounting frame which is both suitable for suspended installation and for floor and stage applications. The array elements can be curved in 1° steps. The individual components are locked via quick-release pins. The mounting frame also allows for suspended installation of the array elements only, without the subwoofer.

Furthermore, the array elements feature a connecting plate for a bracket for mounting it onto a stand. With the accessories LR-1000U and KM-21367, which are both available at option, the system also allows for a ground-stacked configuration. For this purpose, the subwoofer cabinet features a recessed M20 mounting plate.

The speaker cables with NEUTRIK SPEAKON connectors are in the scope of delivery and allow to connect the parts with each other and with the subwoofer.



Connection to the mains is done via a POWERCON jack, suitable mains cable AAC-115P is included in the delivery.

The robust wooden cabinets feature grilles and a durable structured coating. The L-RAY/1000 systems are a very high-quality solution for every PA application where both perfect tonality and perfect radiation across the room are required. The advantages of the system particularly take effect with fixed installations in clubs and discotheques as well as mobile stage applications of medium size. For larger PA applications, the use of several L-RAY in a cluster is recommended.

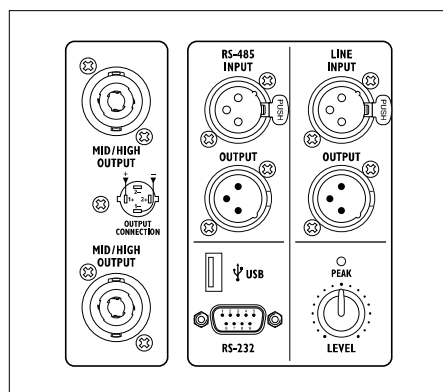

Model	L-RAY/1000
Total output power	1,000 W
Power rating (RMS)	700 W (350 W + 350 W)
Frequency range	50-25,000 Hz
THD	< 0.1%
S/N ratio	80 dB
Input signal	1-10 V/30 kΩ
Sensitivity	98 dB/W/m
Beam angle	hor. 120°, vert. 30°-90° var.
Power supply	~ 230 V/50 Hz/1,400 VA
Weight	47.88 kg
Inputs	XLR jack (line), NEUTRIK SPEAKON (speaker) PowerCon (power supply)
Outputs	XLR par. out (line), NEUTRIK SPEAKON par. out (speaker)

### LR-1000U

Order No. 0254730

#### U-bracket

- This U-bracket allows for an upright installation (ground-stacked configuration) of the L-RAY/1000 system
- The mid-high range unit can be tilted by +/-15°

- Supplied with mounting and adjusting elements
- Ground-stacked configuration with L-RAY/1000 (recommended distance tube: KM-21367)
- To be mounted onto a stand



## PROTON-15MK2

Order No. 0250040



### Compact professional active PA system, 1,200 W

- Subwoofer/satellite system with integrated 3-channel amplifier
- High-quality cabinets made of birch plywood (multiplex)
- Durable two-component PU coating
- High-performance bass-reflex subwoofer system with 38 cm (15") bass speaker
- 20 cm (8") midrange speaker providing a powerful sound and 25 mm (1") CD horn tweeter, constant directivity
- Adjustable volume balance between subwoofer and satellites

- Limiter and surround effect circuit
- Satellites can be stored in the subwoofer cabinet
- Supplied with speaker cables with NEUTRIK SPEAKON plugs (2 x 8 m)
- Subwoofer with M20 mounting plate (recommended distance tube: KM-21367, available at option)
- 75 mm castors with brakes, protective cover

#### Supplied w/o stands.

Model	PROTON-15MK2
Total output power	1,200 W
Power rating (RMS)	400 W (SUB), 2 x 100 W (SAT)
Frequency range	34-20,000 Hz
S/N ratio	> 80 dB
Input signal	260 mV-7 V (line), 280 mV-7 V (line)
Number of speakers	5
Power supply	~ 230 V/50 Hz/1,270 VA
Dimensions	220 x 370 x 175 mm (satellite), 420 x 535 x 600 mm (subwoofer)
Weight	6 kg (satellite), 32 kg (subwoofer), 44 kg (system)
Inputs	2 x comb. XLR/6.3 mm jack (line), 1 x RCA L/R (line)
Outputs	2 x XLR (bal.), 1 x RCA L/R (unbal.), 2 x NEUTRIK SPEAKON, 8 Ω



## PROTON-18NEO

Order No. 0250050



### Compact professional active PA system, 2,300 W

- Subwoofer/satellite system with integrated 3-channel amplifier
- Lightweight due to the application of neodymium speakers and class D amplifier
- High-quality cabinets made of birch plywood (multiplex)
- Durable two-component PU coating
- High-performance bass-reflex subwoofer system with 46 cm (18", Faital) bass speaker
- 25 cm (10", Faital) midrange speaker providing a powerful sound and 25 mm (1") CD horn tweeter, constant directivity

- Adjustable volume balance between subwoofer and satellites
- Balanced (comb. XLR) and unbalanced (RCA) inputs and parallel outputs
- Limiter
- Stereo/mono selection, surround effect circuit
- Satellites can be stored in the subwoofer cabinet
- Supplied with speaker cables with NEUTRIK SPEAKON plugs

- Stand sleeve in the satellites
- Subwoofer with M20 mounting plate (recommended distance tube: KM-21367, available at option)
- 75 mm castors with brakes
- Protective cover

#### Supplied w/o stands.

Model	PROTON-18NEO
Total output power	2,300 W
Power rating (RMS)	800 W (SUB), 2 x 250 W (SAT)
Frequency range	30-20,000 Hz
S/N ratio	> 80 dB
Input signal	260 mV-7 V (line), 280 mV-7 V (line)
Number of speakers	5
Power supply	~ 230 V/50 Hz/2,750 VA
Dimensions	279 x 465 x 229 mm (satellite), 516 x 642 x 718 mm (subwoofer)
Weight	8 kg (satellite), 41 kg (subwoofer), 57 kg (system)
Inputs	2 x comb. XLR/6.3 mm (line), 1 x RCA L/R (Line)
Outputs	2 x XLR (bal.), 1 x RCA L/R (unbal.), 2 x NEUTRIK SPEAKON, 8 Ω



# Components

## Stage and Audio Accessories

### MS-92/SW

Order No. 0236160

**Microphone floor stand**, high-quality version. With movable boom of adjustable length and shock-absorbing folding feet. Thread: 9 mm ( $\frac{3}{8}$ ").

- Mat black lacquered
- Adjustable boom length: 55-94 cm
- Adjustable height: 103-232 cm
- Storage dimensions: 10 x 105 cm
- Weight: 2.6 kg



### MS-90/SW

Order No. 0233780

**Microphone floor stand**, high-quality version. With movable boom and shock-absorbing folding feet.

- Thread: 9 mm ( $\frac{3}{8}$ ").
- Mat black lacquered
  - Boom length: 74 cm
  - Adjustable height: 105-213 cm
  - Storage dimensions: 11 x 98 cm
  - Weight: 2.58 kg



### MS-60/SW

Order No. 0232930

**Microphone floor stand**, with movable boom of adjustable length and shock-absorbing folding feet.

- Thread: 16 mm ( $\frac{5}{8}$ " and 9 mm ( $\frac{3}{8}$ ").
- Mat black lacquered
  - Adjustable boom length: 56-95 cm
  - Adjustable height: 106-242 cm
  - Storage dimensions: 10 x 98 cm
  - Weight: 2.5 kg



### MS-50/SW

Order No. 0232920

**Microphone floor stand**, with movable boom and shock-absorbing folding feet. Thread: 16 mm ( $\frac{5}{8}$ " and 9 mm ( $\frac{3}{8}$ ").

- Mat black lacquered
- Boom length: 72 cm
- Adjustable height: 99-225 cm
- Storage dimensions: 10 x 93 cm
- Weight: 2.4 kg



### MS-40/SW

Order No. 0232900

**Microphone floor stand**, with pivoting boom and shock-absorbing folding feet. Thread: 16 mm ( $\frac{5}{8}$ " and 9 mm ( $\frac{3}{8}$ ").

- Mat black lacquered
- Boom length: 72 cm
- Adjustable height: 95-210 cm
- Storage dimensions: 9 x 88 cm
- Weight: 1.88 kg



### MS-20/SW

Order No. 0232870

**Microphone floor stand**, with movable boom of adjustable length and shock-absorbing folding feet.

- Thread: 9 mm ( $\frac{3}{8}$ ").
- Mat black lacquered
  - Adjustable boom length: 41-60 cm
  - Height: 56 cm
  - Storage dimensions: 10 x 56 cm
  - Weight: 1.8 kg



### KM-210/9

Order No. 0236240



**Microphone floor stand**, with movable boom of adjustable length and shock-absorbing folding feet. Thread: 9 mm (3/8").

- Mat black lacquered
- Adjustable boom length: 46-77 cm
- Adjustable height: 90-160 cm
- Weight: 3.1 kg



### KM-259

Order No. 0236260



**Half-height microphone floor stand**, with movable boom of adjustable length and shock-absorbing folding feet. Thread: 9 mm (3/8").

- Mat black lacquered
- Adjustable boom length: 47-77 cm
- Adjustable height: 43-64 cm
- Weight: 2.05 kg



### KM-26085

Order No. 0236270

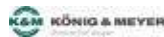

**Microphone floor stand with one-hand height adjustment**, mat black lacquered, with shock-absorbing black diecast base (Ø 25 cm).

- Handle with soft-touch coating
- Thread: 9 mm (3/8")
- Adjustable height: 106-179 cm
- Weight: 2.89 kg



### MS-28

Order No. 0235440

**Microphone floor stand**, mat black lacquered, with shock-absorbing black diecast base (Ø 25 cm). Very robust and stable version.

- Thread: 9 mm (3/8")
- Adjustable height: 88-156 cm
- Weight: 4.5 kg



### KM-101

Order No. 0254660



**Music stand**

- Black lacquered steel version
- Folding for compact storage: 37 x 4,5 x 7 cm
- Adjustable height: 65-122.5 cm
- Music sheet holder: 44 x 21.5 cm
- 2-fold telescopic tube combination
- Tripod folding feet
- Weight: 1.04 kg



### MSS-20/SW

Order No. 0251530

**Professional music stand**

- Black lacquered stand and music sheet holder
- Adjustable height: 102-153 cm
- Tilttable music sheet holder, removable, dimensions: 49 x 34 cm
- Total weight: 3.4 kg





# Components

## Stage and Audio Accessories

### KM-214/6

Order No. 0112070



#### Speaker stand

- Lightweight aluminium version, mat black lacquered
- Height adjustable in 5 steps (137-218 cm), with locking pin, additionally secured via locking screw
- 35 mm spigot
- Max. load/central weight concentration: 50 kg
- Weight: 4.3 kg
- Type approved by TÜV (Technical Inspection Authority, Germany)



### KM-21435

Order No. 0112060



#### Speaker stand

- Robust steel version, mat black lacquered
- Height adjustable in 5 steps (144-223 cm), user-friendly locking due to push-button system, add. secured via locking screw
- Integrated shock absorber
- 35 mm spigot
- Max. load/central weight concentration: 50 kg
- Weight: 5.5 kg
- Type approved by TÜV (Technical Inspection Authority, Germany)



### PAST-250/SW

Order No. 0120420



#### Professional speaker stand

- Lightweight aluminium version
- Air-suspended centre column
- Height adjustable in 5 steps, with locking pin
- Aluminium, black



### PAST-122/SW

Order No. 0118700

**Speaker stand**, stable steel tube version, height adjustable in 5 steps, with locking pin.

- Steel, black



### PAST-120/SW

Order No. 0121710

#### Speaker stand

- Robust steel tube version
- Height adjustable in 6 steps, with locking pin
- High stability due to magnesium joint sleeve
- Steel, black



### PAST-164/SW

Order No. 0111960

#### Speaker stand

- Extra lightweight aluminium version
- Height adjustable in 6 steps, with locking pin
- Aluminium, black



### PAST-200/SW

Order No. 0120380



#### Professional speaker stand

- Lightweight aluminium version
- Requires little floor space
- Air-suspended centre column
- Height adjustable in 4 steps, with locking pin
- Aluminium, black



### PAST-125/SW

Order No. 0118870

#### Speaker stand

- Robust steel tube version
- Requires little floor space
- Height adjustable in 3 steps, with locking pin
- High stability due to magnesium joint sleeve
- Steel, black



Model	PAST-250/SW	PAST-122/SW	PAST-120/SW	PAST-164/SW	PAST-200/SW	PAST-125/SW
Features	air-suspended centre column	-	magnesium joint sleeve	-	air-suspended centre column	-
Material	aluminium	steel tube	steel tube	aluminium	aluminium	steel tube
Colour	black	black	black	black	black	black
Max. load/centr. weight concentr.	40 kg	30 kg	40 kg	30 kg	30 kg	40 kg
Tube diameter	Ø 35 mm	Ø 35 mm	Ø 35 mm	Ø 35 mm	Ø 35 mm	Ø 35 mm
Adjustable height	147-218 cm	130-205 cm	130-200 cm	140-200 cm	107-157 cm	92-137 cm
Storage dimensions	106 x 15 cm	107 x 13 cm	110 x 15 cm	103 x 14 cm	95 x 14 cm	76 x 10 cm
Weight	2.8 kg	4.1 kg	4.6 kg	1.6 kg	2.18 kg	3.18 kg
Special feature	adjustable in 5 steps	adjustable in 5 steps	adjustable in 6 steps	adjustable in 6 steps	adjustable in 4 steps	adjustable in 3 steps

### KM-26735

Order No. 0112460



**Speaker stand**, with flat diecast base (Ø 450 mm).

- Decorative and space-saving design
- Robust steel version, mat black lacquered
- Height adjustable in 4 steps (110-178 cm), with locking pin, additionally secured via locking screw
- 35 mm spigot
- Max. load/central weight concentration: 20 kg
- Weight: 9.64 kg
- Delivery consists of 2 boxes



### KM-21302

Order No. 0112030



**Telescopic speaker stand**

- Robust steel version, mat black lacquered
- Crank handle with push-button for unlocking and locking screw
- Adjustable height: 138-218 cm
- 35 mm spigot with integrated M10 threaded bushing
- Max. load/central weight concentration: 40 kg
- Weight: 7.5 kg
- Type approved by TÜV (Technical Inspection Authority, Germany)



### PAST-280SET

Order No. 0111990

**Speaker stand set**, consisting of two aluminium stands PAST-280/SW with locking system and a nylon tripod bag. For specifications, please refer to the individual items.



### PAST-164SET

Order No. 0111970

**Speaker stand set**, consisting of two aluminium stands PAST-164/SW and a nylon tripod bag. For specifications, please refer to the individual items.



### PAST-125SET

Order No. 0118910

**Speaker stand set**, consisting of two steel stands PAST-125/SW and a nylon tripod bag. For specifications, please refer to the individual items.



### PAST-122SET

Order No. 0118710

**Speaker stand set**, consisting of two steel stands PAST-122/SW and a nylon tripod bag. For specifications, please refer to the individual items.



### PAST-28/SW

Order No. 0118900

**Distance tube**, for stand inserts with standard diameter.

- Black lacquered steel tube version
- Height adjustable in 3 steps (83-123 cm), with locking pin
- Load capacity: 30 kg
- Weight: 1.78 kg



### PAST-25/SW

Order No. 0129870

**Distance tube**, for stand inserts with standard diameter.

- Black lacquered steel tube version
- Height adjustable in 5 steps (86-134 cm), with locking pin
- Load capacity: 30 kg
- Weight: 1.4 kg



### KM-21367

Order No. 0112140



**Distance tube**, with patented expanding mandrels 'ring lock' for a secure and low-resonance connection via plastic expanding jaws at the top and M20 threaded bolt at the bottom.

- For stand inserts with standard diameter
- Mounting plate with M20 inside thread KM-24116 is available at option
- Black lacquered steel tube version
- Height adjustable in 3 steps (98-137 cm), with locking screw
- Weight: 2.56 kg



### KM-21366

Order No. 0112040



**Distance tube**, with patented expanding mandrels on both sides ('ring lock') for a secure and low-resonance connection via movable plastic splints.

- For stand inserts with standard diameter
- Black lacquered steel tube version
- Height adjustable in 4 steps (95-137 cm), with locking screw
- Weight: 2.34 kg



# Components

## Stage and Audio Accessories

### KM-12190

Order No. 0259007



#### Laptop stand

- Easily assembled and disassembled
- High stability
- Lightweight
- Individually adjustable for laptops, mixers or CD players
- Horizontal application height: 320 mm, 3-step tilt
- Supplied with support pads to protect the devices



### KM-18990

Order No. 0257710



#### Keyboard stand

- Double brace steel version
- Height adjustable in steps of 5°, with quick-acting tension lever
- 4 slip-resistant foot caps, one of which is adjustable in height to compensate for uneven ground
- Load capacity: 50 kg
- Support: 327-789 x 350 mm
- Height: 594-946 mm
- Weight: 5.64 kg



### KS-85/SW

Order No. 0251980

#### Universal stand

- Double brace steel version
- Lock-in with 7 locking positions, to be easily adjusted via lever at the upper side of the stand
- Feet can be adjusted in height to compensate floor unevenness
- Load capacity: 50 kg
- Support: 40 x 82 cm
- Max. height: 98 cm
- Tube: Ø 28 mm



### KM-12225

Order No. 0259004



#### Tray

- For mixers, controllers, tablet PCs, percussion instruments and music accessories
- Locking clip (tube diameter: up to 30 mm)
- Usable tray space: 250 x 330 mm
- Robust steel plate with cable routing
- Vibration-reducing foam insert
- Distance to the stand and alignment of the tray can be adjusted



### KM-17650

Order No. 0259003



#### Guitar stand, 'Carlos'.

- Lightweight plastic construction for acoustic guitars or electric guitars
- Felt pads to protect guitars
- Neck lock (security lock) for securely holding the guitar
- Flat folding for easy transport
- Suitable for any guitar lacquer (including nitro lacquer)



### KM-17515

Order No. 0259002



#### 5 guitar stand, 'Guardian 5'.

- Multi-guitar stand for 5 acoustic guitars, electric guitars or electric bass guitars
- Flexible protective bars
- Translucent elastomer support elements are suitable for any guitar lacquer (including nitro lacquer)
- Guitars can be held from either side
- Integrated pick holder
- Space-saving design
- Can conveniently be carried due to folding mechanism



### KM-17525

Order No. 0259001



#### 5 guitar stand, 'Guardian 5'.

- Multi-guitar stand for 5 electric guitars or electric bass guitars
- Flexible protective bars
- Translucent elastomer support elements are suitable for any guitar lacquer (including nitro lacquer)
- Guitars can be held from either side
- Integrated pick holder
- Can conveniently be carried due to folding mechanism



### KM-19740

Order No. 0255910



**Holder for tablet PCs**, with mounting clamp for stands.

- For accepting devices with a height of 120-220 mm
- Tension spring for easy insertion and removal
- Adjustable retaining clamp
- Can be rotated for portrait or landscape format, tiltable
- To be secured with clamp for mounting onto microphone stands (tube diameter: up to 30 mm)



Supplied w/o tablet PC and stand.

### KM-19742

Order No. 0255920



**Holder for tablet PCs**, with threaded bolt for stands.

- For accepting devices with a height of 120-220 mm
- Tension spring for easy insertion and removal
- Adjustable retaining clamp
- Can be rotated for portrait or landscape format, tiltable
- 9 mm (3/8") threaded bolt for mounting onto microphone stands



Supplied w/o tablet PC and stand.

### NPL-302

Order No. 0259861

**Music stand light with 2 x LED gooseneck light and clip**

- 6 white COB LEDs each of high luminous intensity, 3 brightness levels
- Power is provided via enclosed power supply or 3 x 1.5 V battery AA size (not supplied)
- Clamp width: up to 30 mm
- Length of gooseneck: 30 cm each



### RLED-111USB

Order No. 0259862



**482 mm (19") rack light, 1 RS, with gooseneck light and USB port**

- 6 white COB LEDs of high luminous intensity
- 3 brightness levels
- Length of gooseneck: 30 cm
- USB port (= 5 V/1.2 A)
- Power is provided via enclosed power supply



### GNL-453XLR

Order No. 0259858

**LED gooseneck light**

- 6 white COB LEDs of high luminous intensity
- 12 V/60 mA
- 3 brightness levels
- 3-pole XLR plug
- Length of gooseneck: 45 cm



### GNL-454XLR

Order No. 0259859

**LED gooseneck light**

- 6 white COB LEDs of high luminous intensity
- 12 V/60 mA
- 3 brightness levels
- 4-pole XLR plug
- Length of gooseneck: 45 cm



### GNL-300USB

Order No. 0259856



**LED gooseneck light**

- 6 white COB LEDs of high luminous intensity
- = 5 V/60 mA
- 3 brightness levels
- USB Type-A plug
- Length of gooseneck: 30 cm



### GNL-450BNC

Order No. 0259857

**LED gooseneck light**

- 6 white COB LEDs of high luminous intensity
- 12 V/60 mA
- 3 brightness levels
- BNC plug-in connector
- Length of gooseneck: 45 cm



# Components

## Stage and Audio Accessories

### MR-162DESK

Order No. 0252180



**Professional rolling case for 482 mm (19") devices**, with 2 integrated desks.

- 9 RS mounting facility for 482 mm top-operated devices (mixers or similar), upward tilting rack rails with click-stop hinges
- 16 RS mounting zone for devices which require horizontal mounting
- Suitable for devices with a maximum depth of 480 mm
- Front part and rear part with integrated folding feet (desk feature), effective surface: approx. 920 x 525 mm each, height: approx. 760 mm each

- 9 mm multiplex wood, moisture repellent, black, plastic-laminated (slightly structured)
- Robust bottom plate, 13 mm thick
- Aluminium profile edges
- Chromium-plated ball protection corners and closing angles
- 100 mm castors, 2 of which are provided with locking brakes
- Butterfly locks
- 2 recessed drop handles at each side ensure safe and convenient handling
- Inside dimensions: 500 x 715 x 520 mm



### MR-106PC

Order No. 0250190



**Flight case**, with integrated laptop rack.

- 6 RS: Vertical profile rails for inserting 482 mm (19") devices. Suitable for devices with a maximum depth of 480 mm
- 8 RS: Horizontal and slightly upward tilted mounting rails for 482 mm (19") top-operated devices, e.g. mixers
- Sliding top part with non-slip surface for laptops
- 9 mm multilayer multiplex wood, black laminated
- Aluminium profile edges

- Chromium-plated ball protection corners, reinforcing angles and connectors
- Butterfly locks and recessed drop handles
- Rear service cover with cable outlet
- Inside dimensions: 515 x 390 x 590 mm
- Outside dimensions: 570 x 445 x 630 mm
- Weight: 20 kg
- Supplied with 32 cage nuts

**Supplied w/o devices.**



### MR-919DJ

Order No. 0244710



**Flight case**, 9 RS, for 482 mm (19") top-operated devices, e.g. mixers. Mounting rails with a fixed inclination angle of approx. 13°, thus the mounting depth varies between 100 and 185 mm.

- Multilayer multiplex wood, black laminated
- Aluminium profile edges
- Chromium-plated ball protection corners, reinforcing angles
- Butterfly locks and recessed drop handles

- Particularly suitable for variable installation of devices using castle nuts M6 x 7 mm; aluminium rails with non-slipping feature (guiding rubber prevents slipping of the castle nuts, thus easy mounting)
- Dimensions: 527 x 230 x 485 mm
- Weight: 8.2 kg
- Supplied with 4 castle nuts

**Supplied w/o devices.**



### RCS-92/SW

Order No. 0111410



**Rack-mount power strip**, with 9 earthed sockets.

- Sockets turned by 45°
- Black aluminium housing
- Removable mounting brackets
- 2 m connection cable with earthed plug

- Cable specification: H05VV-F3G x 1.5 mm<sup>2</sup>, 3,600 VA max.
- Dimensions: 482 x 44 x 45 mm, 1 RS

### RCS-18

Order No. 0111200



**Rack-mount power strip**, with 8 earthed sockets and overvoltage protection.

- Child safety sockets
- Sockets turned by 45°
- Illuminated main switch
- Black plastic housing

- 1 m connection cable with earthed plug, cable inlet can be turned by 90° via flexible joint
- Cable specification: H05VV-F3G x 1.5 mm<sup>2</sup>, 3,600 VA max.
- Dimensions: 482 x 44 x 60 mm, 1 RS

### RCS-85/SW

Order No. 0111850



**Rack-mount power strip**, with an illuminated main switch on the front panel and 8 earthed sockets on the rear panel.

- Sockets turned by 45°
- Black aluminium housing
- Removable mounting brackets to allow for reversed mounting

- 2 m connection cable with earthed plug
- Cable specification: H05VV-F3G x 1.5 mm<sup>2</sup>, 3,600 VA max.
- Dimensions: 482 x 44 x 52 mm, 1 RS

### MCS-180

Order No. 0050002



**Rack-mount power strip**, with 8 earthed sockets.

- Sockets can be switched individually via illuminated switches
- Black sheet steel housing
- 1.8 m connection cable with earthed plug

- Cable specification: H05VV-F3G x 1.5 mm<sup>2</sup>, 3,600 VA max.
- Dimensions: 482 x 89 x 110 mm, 2 RS





## Series of Flight Cases

With vertical profile rails for inserting 482 mm (19") devices. Suitable for devices with a maximum depth of 480 mm.

Horizontal and slightly upward tilted mounting rails for 482 mm (19") top-operated devices, e.g. mixers.

- Multilayer multiplex wood, black laminated
- Aluminium profile edges
- Chromium-plated ball protection corners, reinforcing angles
- Each case is equipped with butterfly locks and recessed drop handles
- The add-on DJ case MR-112DJ is supplied with 4 castors (2 of which are provided with a brake)
- Supplied with cage nuts



Supplied w/o devices.

Model	Order No.	Rack spaces, RS	Mounting accessories	Inside dimensions	Outside dimensions	Weight	Position
MR-112DJ	0246760	12 vertical, 10 horizontal	44 cage nuts	520 x 660 x 590 mm	560 x 850 x 640 mm	30.1 kg	A
MR-106DJ	0245980	6 vertical, 10 horizontal	32 cage nuts	520 x 390 x 590 mm	550 x 440 x 640 mm	16.82 kg	B
MR-104DJ	0243450	4 vertical, 10 horizontal	28 cage nuts	520 x 310 x 590 mm	560 x 350 x 640 mm	14.96 kg	C

## MR-246

Order No. 0250520



### Professional DJ flight case,

with a low depth, for 482 mm (19") devices.

Consisting of 3 sections:

- Section 1 (top), e.g. for control panels of dual CD players
- Section 2 (middle), e.g. for mixers
- Section 3 (bottom), e.g. for CD player mechanisms or amplifiers

### Features

- 10 mm multiplex wood, black laminated
- Aluminium profile edges, reinforcing angles
- Chromium-plated ball protection corners (stackable)
- Recessed drop handles and butterfly locks
- Aluminium rails with M6 cage nuts for variable installation of devices, no slipping of the cage nuts, thus easy mounting
- Removable cover (not shown)
- Service door at the rear side with cable inlet
- Max. inside depth behind the front panel: 330 mm
- Supplied with cage nuts

Model	MR-246
Size	482 mm (19")
Rack spaces, RS	2 RS (section 1), 4 RS (section 2), 6 RS (section 3)
Colour	black
Mounting accessories	20 cage nuts
Usable depth	330 mm
Outside dimensions	545 x 545 x 490 mm
Weight	16.5 kg

### Sample configuration

- Section 1 (2 RS), e.g. with control panel of CD-292USB
  - Section 2 (4 RS), e.g. with mixer MPX-44/SW
  - Section 3 (6 RS), e.g. with player mechanism of CD-292USB, amplifier STA-102, STA-500 or STA-700, MP3 player DPR-110 and rack panel RCP-8701U
- Should the existing rack spaces not be required, we recommend to use rack panels, e.g. RCP-8701U (1 RS) or RCP-8702U (2 RS).



Supplied w/o devices.

## MR-405TXS

Order No. 0244460



**Flight case, 5 RS**, particularly suitable for wireless microphone systems, e.g. 4 x receiver unit TXS-871/ TXS-872/TXS-875 and 1 x antenna splitter TXS-870DS. Also suitable for other wireless microphone systems and 482 mm devices with a max. depth of 255 mm behind the front panel.

- Storage compartments with holding straps for transmitter and accessories

- Multilayer multiplex wood, black laminated, aluminium profile edges, butterfly locks, recessed drop handles
- Supplied with mounting screws
- Dimensions: 540 x 265 x 460 mm
- Weight: 9,4 kg



# Components

## Stage and Audio Accessories

### Rolling Flight Cases

482 mm  
19"

With vertical profile rails at the front and rear for inserting 482 mm (19") devices. In addition, they are fitted with upward tilting mounting rails (10 RS) for 482 mm (19") top-operated devices (e.g. mixers). Suitable for devices with a maximum depth of 480 mm.

- Multilayer multiplex wood, black laminated
- Aluminium profile edges
- Chromium-plated ball protection corners, reinforcing angles and connectors
- Each case is equipped with butterfly locks and recessed drop handles
- There is a difference of 2 RS only between the models MR-182 and MR-162 which allows for an optimum working height, depending on the user's height
- Supplied with cage nuts



Model	Order No.	Rack spaces, RS	Mounting accessories	Inside dimensions	Outside dimensions	Weight	Position
MR-182	0244990	18	56 cage nuts	500 x 1,080 x 680 mm	550 x 1,180 x 720 mm	42.62 kg	A
MR-162	0244980	16	52 cage nuts	500 x 910 x 680 mm	550 x 1,080 x 720 mm	41.08 kg	B
MR-122	0244970	12	44 cage nuts	500 x 740 x 680 mm	550 x 910 x 720 mm	35.12 kg	C

### Series of Flight Cases

482 mm  
19"

- Multilayer multiplex wood, black laminated
- Aluminium profile edges
- Chromium-plated ball protection corners, reinforcing angles and connectors
- Profile rails at the front and rear
- Suitable for devices with a depth of approx. 480 mm and 20 RS max. Each case is equipped with butterfly locks and recessed drop handles. The cases from 10 RS to 20 RS are supplied with 4 castors, 2 of which are provided with brakes
- Supplied with cage nuts
- Max. inside depth behind the front panel: 480 mm, inside depth before the front panel: 90 mm

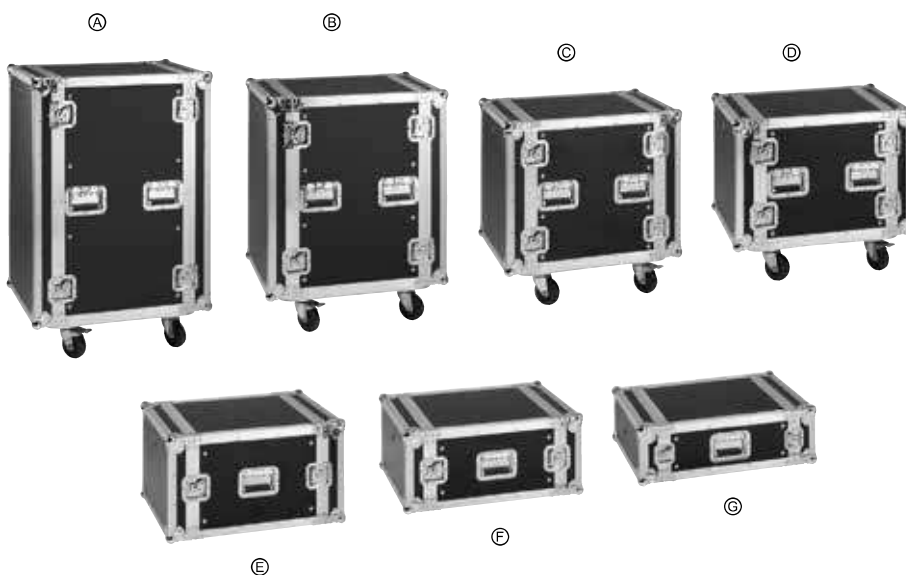

Model	Order No.	Rack spaces, RS	Mounting accessories	Inside dimensions	Outside dimensions	Weight	Position
MR-720	0245060	20	40 cage nuts	500 x 900 x 680 mm	550 x 1,080 x 720 mm	36.72 kg	A
MR-716	0245050	16	32 cage nuts	500 x 725 x 680 mm	550 x 910 x 720 mm	32.47 kg	B
MR-712	0245040	12	24 cage nuts	500 x 545 x 680 mm	550 x 730 x 720 mm	27.06 kg	C
MR-710	0245030	10	20 cage nuts	500 x 455 x 680 mm	550 x 640 x 720 mm	25.64 kg	D
MR-708	0245020	8	16 cage nuts	500 x 370 x 680 mm	550 x 420 x 720 mm	15.7 kg	E
MR-706	0245010	6	24 cage nuts	500 x 280 x 680 mm	550 x 330 x 720 mm	13.98 kg	F
MR-704	0245000	4	8 cage nuts	500 x 190 x 680 mm	550 x 240 x 720 mm	11.98 kg	G

## Series of Flight Cases

- Multilayer multiplex wood, black laminated
- Aluminium profile edges
- Chromium-plated ball protection corners, reinforcing angles and connectors
- Aluminium rails at the front and rear with M6 cage nuts for variable installation of devices, no slipping of the cage nuts, thus easy mounting

### Standard series:

For devices with a depth of approx. 420 mm and 10 RS max., 5 layers of multiplex, 6 mm thick. Equipped with butterfly locks and recessed drop handles, MR-402 and MR-403 with strap handles.

Max. inside depth behind the front panel: 440 mm.

Max. inside depth before the front panel: 55 mm.

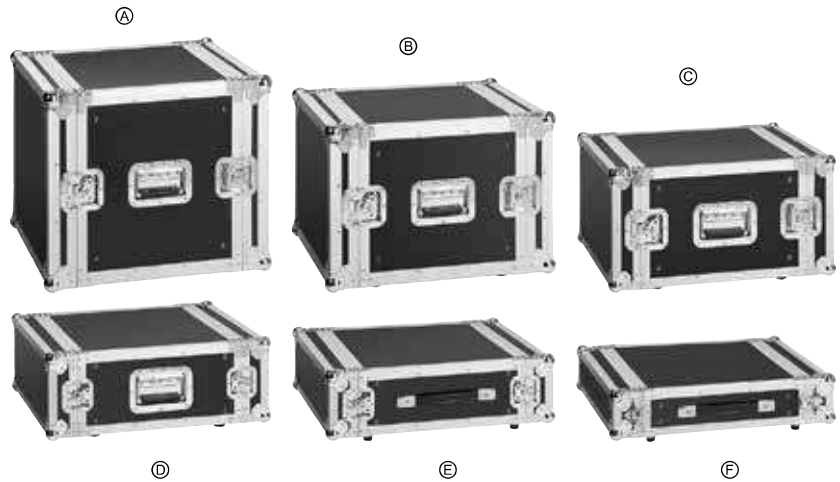

Model	Order No.	Rack spaces, RS	Mounting accessories	Inside dimensions	Outside dimensions	Weight	Position
MR-410	0242270	10	24 cage nuts	485 x 450 x 530 mm	545 x 510 x 585 mm	17.3 kg	A
MR-408	0242260	8	24 cage nuts	485 x 365 x 530 mm	545 x 420 x 585 mm	15.54 kg	B
MR-406	0242250	6	24 cage nuts	485 x 270 x 530 mm	535 x 320 x 580 mm	9.72 kg	C
MR-404	0242240	4	16 cage nuts	485 x 185 x 530 mm	535 x 225 x 580 mm	8.04 kg	D
MR-403	0242230	3	12 cage nuts	485 x 140 x 530 mm	555 x 185 x 580 mm	6.68 kg	E
MR-402	0242220	2	8 cage nuts	485 x 92 x 530 mm	555 x 140 x 580 mm	5.64 kg	F

## MR-1918/SW

Order No. 0247450



**Table rack**, with a total of 8 RS.

- Vertical version for accepting 482 mm (19") devices which require horizontal mounting, e.g. CD players
- Black lacquered

Model	MR-1918/SW
Rack spaces, RS	8
Outside dimensions	550 x 475 x 390 mm
Max. load capacity	20 kg
Weight	2.1 kg



## MZF-8645

Order No. 0123500

**Set of cage nuts and screws**, for mounting 482 mm (19") inserts into racks and flight cases. The set consists of:

- 4 x M6 cage nut
- 4 x M6 x 15 mm recessed head screw
- 4 x plastic washer



## MZF-8646

Order No. 0126730

**Mounting set**, for mounting 482 mm (19") devices into racks and flight cases in any required height. The set consists of:

- 12 x M6 x 12 mm recessed head screw
- 12 x M6 nut
- 12 x plastic washer



## MZF-8648

Order No. 0129410

**Set of cage nuts and screws**, for mounting 482 mm (19") inserts into racks and flight cases. The set consists of:

- 4 x M6 cage nut
- 4 x M6 x 15 mm recessed head screw
- 4 x plastic washer



## Components

### Stage and Audio Accessories

#### MR-10LIGHT

Order No. 0250260

**Rolling flight case**, for transporting light effect units.

- 2 partitions and a storage tray, several positions possible
- Multilayer multiplex wood, black laminated
- Aluminium profile edges
- Chromium-plated ball protection corners
- Butterfly locks, recessed drop handles
- 4 castors
- Stackable due to indentations for the castors in the cover of the flight case
- Inside dimensions: 1,175 x 580 x 540 mm
- Outside dimensions: 1,220 x 765 x 625 mm
- Weight: 54 kg



#### MR-42LIGHT

Order No. 0253060

**Rolling flight case**, for transporting light effect units.

- Multilayer multiplex wood, black laminated
- Aluminium profile edges
- Chromium-plated ball protection corners, reinforcing angles
- Butterfly locks, recessed drop handles
- 4 castors (two of which are provided with a brake)
- Carpet lining
- 2 inside partitions, several positions possible
- Inside dimensions: 582 x 592 x 554 mm
- Outside dimensions: 620 x 770 x 620 mm
- Weight: 31.4 kg



#### MR-6LIGHT

Order No. 0250820

**Universal rolling flight case**, for transporting e.g. stands, cables and accessories for stage applications, DJs or lighting equipment.

- Due to special design, flight case can easily be pulled like a trolley
- Multilayer multiplex wood, black laminated
- Aluminium profile edges
- Chromium-plated ball protection corners
- Butterfly locks, recessed drop handles
- 4 castors
- Foam-padded interior
- Inside dimensions: 980 x 345 x 345 mm
- Outside dimensions: 1,050 x 440 x 410 mm
- Weight: 19.2 kg



## MR-3LIGHT

Order No. 0244420

## MR-2LIGHT

Order No. 0244410

**Universal flight cases**, for transporting e.g. light effect units, cables, accessories.

- Multilayer multiplex wood, black laminated
- Aluminium profile edges
- Chromium-plated ball protection corners, reinforcing angles
- Butterfly locks, recessed drop handles

- Foam-padded interior
- Inside dimensions: 525 x 315 x 420 mm (MR-3LIGHT), 450 x 220 x 350 mm (MR-2LIGHT)
- Outside dimensions: 570 x 355 x 470 mm (MR-3LIGHT), 500 x 270 x 400 mm (MR-2LIGHT)
- Weight: 8.6 kg (MR-3LIGHT), 6.8 kg (MR-2LIGHT)



## MR-108T

Order No. 0243270



**Hard-sided flight case, 8 RS, for 482 mm (19") devices.**

- Devices can be inserted from both sides (double door system)
- Scratch-proof and shock-proof, black ABS housing
- Fully closed 3 mm aluminium profile frames
- High stability despite low weight
- Stackable
- Robust carrying handles and additional telescopic handle

- Butterfly locks
- Castors
- Mounting depth behind front panel: 480 mm for 6 RS  
Mounting depth behind front panel: 120 mm for 2 RS
- Supplied with cage nuts and recessed head screws
- Inside dimensions: 550 x 444 x 360 mm
- Outside dimensions: 580 x 560 x 450 mm
- Weight: 9 kg



## Hard-Sided Flight Cases

**For 482 mm (19") devices.**



- Devices can be inserted from both sides (double door system)
- Scratch-proof and shock-proof black ABS housing
- Fully closed 3 mm aluminium profile frames
- High stability despite low weight
- Stackable
- Robust carrying handles
- Butterfly locks
- Mounting depth behind the front panel: 480 mm
- Supplied with mounting screws

**Supplied w/o devices.**



Model	Order No.	Rack spaces, RS	Mounting accessories	Inside dimensions	Usable depth	Outside dimensions	Weight	Position
MR-108	0247860	8	mounting screws	444 x 375 x 530 mm	480 mm	540 x 430 x 560 mm	7,38 kg	A
MR-106	0247850	6	mounting screws	444 x 285 x 530 mm	480 mm	540 x 340 x 560 mm	6,38 kg	B
MR-104	0247840	4	mounting screws	444 x 195 x 530 mm	480 mm	540 x 250 x 560 mm	5,46 kg	C
MR-102	0247830	2	mounting screws	444 x 110 x 530 mm	480 mm	540 x 160 x 560 mm	4,14 kg	D



# Components

## Cables and Plug-in Connectors

### XLR Cables

#### Line and microphone extension cables.

- Fitted with NEUTRIK connectors
- 1 x XLR inline jack and 1 x XLR plug, balanced
- Shielded low-noise OFC cable material, Ø 6.5 mm



Model	Order No.	Length	Colour	Cable diameter
MECN-100/BL	0065920	1 m	blue	Ø 6.5 mm
MECN-100/RT	0065930	1 m	red	Ø 6.5 mm
MECN-100/SW	0065940	1 m	black	Ø 6.5 mm
MECN-200/BL	0065950	2 m	blue	Ø 6.5 mm
MECN-200/RT	0065960	2 m	red	Ø 6.5 mm
MECN-200/SW	0065970	2 m	black	Ø 6.5 mm
MECN-600/BL	0065980	6 m	blue	Ø 6.5 mm
MECN-600/RT	0065990	6 m	red	Ø 6.5 mm
MECN-600/SW	0066000	6 m	black	Ø 6.5 mm
MECN-1000/BL	0066010	10 m	blue	Ø 6.5 mm
MECN-1000/RT	0066020	10 m	red	Ø 6.5 mm
MECN-1000/SW	0066030	10 m	black	Ø 6.5 mm
MECN-1500/SW	0066040	15 m	black	Ø 6.5 mm
MECN-2000/SW	0066050	20 m	black	Ø 6.5 mm

### XLR cables

#### Line and microphone extension cables

- Fitted with REAN connectors (made by NEUTRIK)
- 1 x XLR inline jack and 1 x XLR plug, balanced
- Shielded low-noise OFC cable material, Ø 5.9 mm



Model	Order No.	Length	Colour	Cable diameter
MECR-50/SW	0069320	0.5 m	black	Ø 5.9 mm
MECR-100/SW	0069270	1 m	black	Ø 5.9 mm
MECR-200/SW	0069300	2 m	black	Ø 5.9 mm
MECR-600/SW	0069330	6 m	black	Ø 5.9 mm
MECR-1500/SW	0069290	15 m	black	Ø 5.9 mm
MECR-2000/SW	0069310	20 m	black	Ø 5.9 mm

### XLR Cables

#### Line and microphone extension cables.

- 1 x XLR inline jack and 1 x XLR plug, balanced
- Shielded low-noise OFC cable material, Ø 6.5 mm



Model	Order No.	Length	Colour	Cable diameter
MEC-50/BL	0061680	0.7 m	blue	Ø 6.5 mm
MEC-50/RT	0061710	0.7 m	red	Ø 6.5 mm
MEC-50/SW	0061720	0.7 m	black	Ø 6.5 mm
MEC-100/BL	0061740	1 m	blue	Ø 6.5 mm
MEC-100/GE	0061750	1 m	yellow	Ø 6.5 mm
MEC-100/GN	0061760	1 m	green	Ø 6.5 mm
MEC-100/RT	0061770	1 m	red	Ø 6.5 mm
MEC-100/SW	0061780	1 m	black	Ø 6.5 mm
MEC-190/BL	0062520	2 m	blue	Ø 6.5 mm
MEC-190/GE	0062530	2 m	yellow	Ø 6.5 mm
MEC-190/GN	0062540	2 m	green	Ø 6.5 mm
MEC-190/RT	0062550	2 m	red	Ø 6.5 mm
MEC-190/SW	0062560	2 m	black	Ø 6.5 mm
MEC-20/BL	0060670	6 m	blue	Ø 6.5 mm
MEC-20/RT	0060700	6 m	red	Ø 6.5 mm
MEC-20/SW	0060710	6 m	black	Ø 6.5 mm
MEC-1000/BL	0062940	10 m	blue	Ø 6.5 mm
MEC-1000/SW	0062510	10 m	black	Ø 6.5 mm
MEC-1500/SW	0062270	15 m	black	Ø 6.5 mm
MEC-2000/SW	0064320	20 m	black	Ø 6.5 mm

## Line Cables

"HIGH QUALITY, HIGHLY FLEXIBLE"

- 3-pole XLR plug and 6.3 mm stereo plug, balanced
- Black, shielded low-noise OFC cable material

Model	Order No.	Length	Colour
MEL-102/SW	0066670	1 m	black
MEL-202/SW	0066680	2 m	black
MEL-602/SW	0066690	6 m	black



## Microphone Cables

- Fitted with NEUTRIK connectors
- 1 x XLR inline jack and 1 x 6.3 mm mono plug
- Shielded low-noise OFC cable material, Ø 6.5 mm

Model	Order No.	Length	Colour	Cable diameter
MMCN-300/SW	0066760	3 m	black	Ø 6.5 mm
MMCN-600/SW	0066060	6 m	black	Ø 6.5 mm
MMCN-1000/SW	0066070	10 m	black	Ø 6.5 mm



## Microphone Cables

- Fitted with 1 x XLR inline jack and 1 x 6.3 mm mono plug
- Shielded low-noise OFC cable material, Ø 6.5 mm

Model	Order No.	Length	Colour	Cable diameter
MMC-300/SW	0066750	3 m	black	Ø 6.5 mm
MMC-600/SW	0060900	6 m	black	Ø 6.5 mm
MMC-1200/SW	0064310	12 m	black	Ø 6.5 mm



## Mono Cables

- Fitted with NEUTRIK connectors
- 2 x 6.3 mm mono plug
- Shielded low-noise OFC cable material, Ø 6.5 mm

Model	Order No.	Length	Colour	Cable diameter
MCCN-150/SW	0065840	1.5 m	black	Ø 6.5 mm
MCCN-300/SW	0065870	3 m	black	Ø 6.5 mm
MCCN-600/SW	0065900	6 m	black	Ø 6.5 mm
MCCN-1000/SW	0065910	10 m	black	Ø 6.5 mm



## Mono Cables

- Shielding
- Fitted with 2 x 6.3 mm mono plug
- Cable outside diameter: Ø 6.5 mm

Model	Order No.	Length	Colour	Cable diameter
MCC-50/RT	0060520	0.5 m	red	Ø 6.5 mm
MCC-50/SW	0060530	0.5 m	black	Ø 6.5 mm
MCC-100/RT	0060400	1 m	red	Ø 6.5 mm
MCC-100/SW	0060410	1 m	black	Ø 6.5 mm
MCC-300/RT	0060460	3 m	red	Ø 6.5 mm
MCC-300/SW	0060470	3 m	black	Ø 6.5 mm
MCC-600/SW	0060590	6 m	black	Ø 6.5 mm
MCC-900/SW	0060650	9 m	black	Ø 6.5 mm



# Components

## Cables and Plug-in Connectors

### Speaker Cables

"HIGHLY FLEXIBLE"

- Fitted with NEUTRIK SPEAKON plugs NL-2FX
- Highly flexible cable material

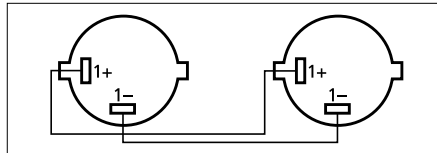

Model	Order No.	Length	Colour	Internal conductor
MSC-502/SW	0112210	2 m	black	2 x 1.5 mm <sup>2</sup>
MSC-505/SW	0129210	5 m	black	2 x 1.5 mm <sup>2</sup>
MSC-510/SW	0129220	10 m	black	2 x 1.5 mm <sup>2</sup>
MSC-515/SW	0129230	15 m	black	2 x 1.5 mm <sup>2</sup>
MSC-520/SW	0112220	20 m	black	2 x 1.5 mm <sup>2</sup>

### Speaker Cables

- Fitted with NEUTRIK SPEAKON plugs NL-2FX
- "Economy" cable material

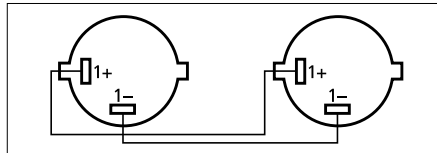

Model	Order No.	Length	Colour	Internal conductor
MSCA-502/SW	0112230	2 m	black	2 x 1.5 mm <sup>2</sup>
MSCA-505/SW	0112240	5 m	black	2 x 1.5 mm <sup>2</sup>
MSCA-510/SW	0112250	10 m	black	2 x 1.5 mm <sup>2</sup>

### Speaker Cables

"HIGHLY FLEXIBLE"

- Fitted with NEUTRIK SPEAKON plugs NL-2FX
- Highly flexible cable material

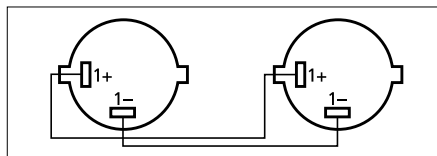

Model	Order No.	Length	Colour	Internal conductor
MSC-102/SW	0112170	2 m	black	2 x 2.5 mm <sup>2</sup>
MSC-105/SW	0125620	5 m	black	2 x 2.5 mm <sup>2</sup>
MSC-110/SW	0125640	10 m	black	2 x 2.5 mm <sup>2</sup>
MSC-115/SW	0125660	15 m	black	2 x 2.5 mm <sup>2</sup>
MSC-120/SW	0112180	20 m	black	2 x 2.5 mm <sup>2</sup>

### Speaker Cables

- Fitted with NEUTRIK SPEAKON plugs NL-2FX
- "Economy" cable material

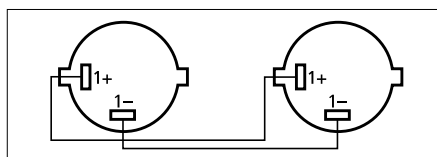

Model	Order No.	Length	Colour	Internal conductor
MSCA-610/SW	0112260	10 m	black	2 x 2.5 mm <sup>2</sup>
MSCA-615/SW	0112270	15 m	black	2 x 2.5 mm <sup>2</sup>
MSCA-620/SW	0112280	20 m	black	2 x 2.5 mm <sup>2</sup>

### Speaker Cables

"HIGHLY FLEXIBLE"

- Fitted with NEUTRIK SPEAKON plugs NL-4FX
- Highly flexible cable material

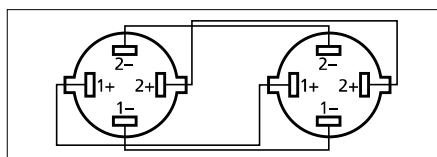

Model	Order No.	Length	Colour	Internal conductor
MSC-202/SW	0112190	2 m	black	4 x 2.5 mm <sup>2</sup>
MSC-205/SW	0125680	5 m	black	4 x 2.5 mm <sup>2</sup>
MSC-210/SW	0125700	10 m	black	4 x 2.5 mm <sup>2</sup>
MSC-215/SW	0125720	15 m	black	4 x 2.5 mm <sup>2</sup>

## DMX Connection Cables

For transmitting digital DMX512 signals or AES/EBU signals.

- Fitted with NEUTRIK XLR plug NC-3MX and NEUTRIK XLR inline jack NC-3FX
- 2 x 0.22 mm<sup>2</sup>

- Double shielding
- Outside diameter: Ø 4.5 mm
- Impedance level: 110 Ω
- Very low capacitance: 57 pF/m



Model	Order No.	Length
CDMXN-150/SW	0112110	1.5 m
CDMXN-300/SW	0112120	3 m
CDMXN-500/SW	0112130	5 m
CDMXN-1000/SW	0112100	10 m

## MSC-1007/SW

Order No. 0062650

### Speaker cable

- 1 x XLR plug and 1 x XLR inline jack
- Cores: 2 x 1.5 mm<sup>2</sup>
- Without shielding
- Length: 10 m

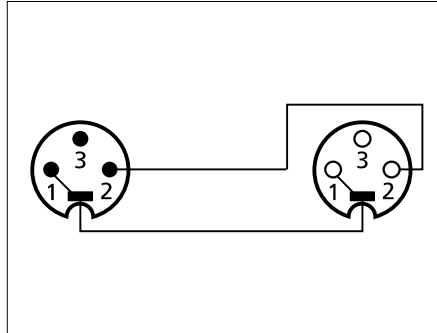

## MSCP-1000/SW

Order No. 0062450

### Speaker cable

- 1 x XLR plug and 1 x 6.3 mm plug
- Cores: 2 x 1.5 mm<sup>2</sup>
- Without shielding
- Length: 10 m

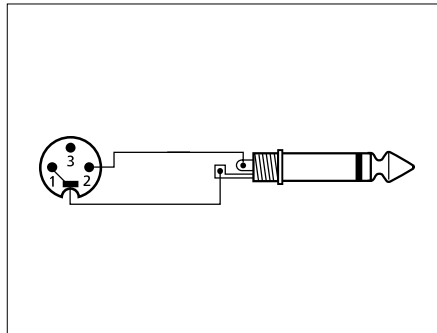

## Speaker Cables

- Fitted with 6.3 mm plug
- Different lengths
- Without shielding

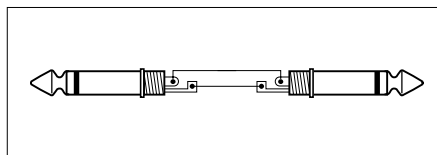

Model	Order No.	Length	Colour	Internal conductor
MSC-150/SW	0060930	1.5 m	black	2 x 1.5 mm <sup>2</sup>
MSC-300/SW	0060960	3 m	black	2 x 1.5 mm <sup>2</sup>
MSC-600/SW	0062500	6 m	black	2 x 1.5 mm <sup>2</sup>
MSC-1000/SW	0062490	10 m	black	2 x 1.5 mm <sup>2</sup>
MSC-1500/SW	0060940	15 m	black	2 x 1.5 mm <sup>2</sup>

## Speaker Cables

### "HIGHLY FLEXIBLE"

- Fitted with NEUTRIK SPEAKON plug NL-2FX and 6.3 mm mono plug
- Highly flexible cable material

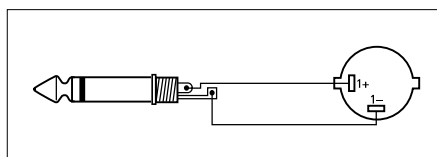

Model	Order No.	Length	Colour	Internal conductor
MSCN-8050/SW	0129380	5 m	black	2 x 1.5 mm <sup>2</sup>
MSCN-8100/SW	0129390	10 m	black	2 x 1.5 mm <sup>2</sup>
MSCN-8150/SW	0129400	15 m	black	2 x 1.5 mm <sup>2</sup>

**KATANA-M1**

Order No. 1000093

**An open secret ...**

With the speaker KATANA-M1, you will achieve an impressive sound and design in your living room. The appealing DIY set convinces with its extraordinary open baffle design. The configuration of the set is the result of extensive, practical experience of our acoustic developers at MONACOR.

The DIY kit has been pre-assembled in an optimum way and contains all necessary components as well as assembly instructions. All you need to assemble the components is a soldering iron, a screwdriver and a side cutter.

The open rear construction allows you to achieve a realistic and impressively spatial sound. The size of the baffle and the choice of speakers are perfectly matched to the application. The wood which has been used is untreated and can be painted as required.

The awareness of having created such a great sound experience with your own hands: priceless.

**The DIY kit KATANA-M1 consists of:**

- 1 x speaker baffle (beech, 20 mm multiplex)
- 1 x speaker base plate
- 2 x side wall
- 1 x hi-fi full range speaker SPX-31M, 20 W, 8 Ω
- 1 x pair of speaker pole terminals BP-500G
- 2 x hi-fi bass-midrange speaker SPM-205/8, 70 W, 8 Ω
- 1 x MKT film capacitor MKTA-220, 22 μF, 250 V
- 1 x transformer core coil LSI-56T, 5,6 mH
- 3 m speaker cable SPC-115CA
- 4 x rubber foot (from the set HF-10)
- Wood glue, solder, mounting screws, assembly instructions

**For full specifications, please refer to individual items.**

**DN-1218PAX**

Order No. 0125210

**2-way crossover network for 8 Ω**

- Highest power rating version for PA
- Optimum filter effect for typical PA bass speakers of 30 cm and 38 cm

Model	DN-1218PAX
General Information	2-way
Output impedance	8 Ω
Crossover frequency	2,500 Hz
Slope/oct.	12 dB/18 dB
Max. input power	600 W
Dimensions	120 x 60 x 132 mm
Weight	1.065 kg

**DN-4**

Order No. 0120200

**3-way crossover network for 8 Ω**

- Air core coils
- High-quality bipolar electrolytic capacitors

Model	DN-4
General Information	3-way
Output impedance	8 Ω
Crossover frequency	650/6,000 Hz
Slope/oct.	12/6 dB
Max. input power	100 W
Dimensions	120 x 23 x 70 mm
Weight	0.315 kg





**SP-8/150PRO**

Order No. 0100710

**Compact PA bass speaker, subwoofer, 150 W, 8 Ω**

- 20 cm (8") bass speaker and subwoofer of high power capability
- Heat-resistant voice coil and ventilated drive system
- Extra long excursion for a deep bass reproduction of high volumes
- Progressive cone suspension for a high operating reliability



- Robust diecast aluminium basket
- Ideally suited for 2-way systems and compact subwoofers

**SP-2RDP**

Order No. 0100370

**Miniature flush-mount speakers, 8 Ω****SP-15**

Order No. 0100310

**Special speaker, 10 W, 8 Ω**

- All-plastic cone with hard suspension
- Moisture-proof
- Special version for signal sounds of alarm systems
- Operating temperature range: -25 °C to +70 °C

**SP-252E**

Order No. 0103990

**Hi-fi bass-midrange speaker, 75 W, 4 Ω**

- All-round speaker
- Foam surround
- Replacement speaker for closed cabinets



Model	SP-8/150PRO	SP-2RDP	SP-15	SP-252E
Impedance (Z)	8 Ω	8 Ω	8 Ω	4 Ω
Frequency range	f3-3,000 Hz	450-15,000 Hz	f3-8,000 Hz	f3-6,000 Hz
Resonant frequency (fs)	56 Hz	-	430 Hz	42 Hz
Power rating (RMS)	150 W	0.25 W	10 W	75 W
Peak music power output (MAX)	300 W	-	15 W	150 W
Sensitivity	93 dB/W/m	power capability: < 1 W	96 dB/W/m	94 dB/W/m
Mounting cutout	Ø 185 mm	Ø 45 mm	Ø 79 mm	Ø 232 mm
Dimensions	Ø 210 mm x 100 mm	Ø 50 mm x 19 mm	85 x 85 x 39 mm	Ø 255 mm x 110 mm
Weight	2.52 kg	0.04 kg	0.355 kg	2.3 kg

**SAM-2**

Order No. 0320670

**Active subwoofer module, 200 W**

- High-power active module
- 24 dB subsonic filter
- Variable low-pass filter: 50-150 Hz (18 dB)
- Semiparametric bass boost (variable 30-50 Hz midrange with boost up to 6 dB, contin, adjustable)
- Contin, adjustable phase control 0-180° for uncompromising room correction and an optimum set-up of your speakers
- Variable high-pass filter: 50-150 Hz



- (12 dB) for equalizing bass freq. of the satellite amplifier and satellite speakers
- Ground lift switch from the studio technology to prevent hum interference

**SAM-200D**

Order No. 0320780

**Class D active subwoofer module, 200 W at 4 Ω**

- High-performance active module in class D technology
- Variable low-pass filter: 40-200 Hz (18 dB)
- Continuously adjustable phase control 0-180° for perfectly matching it to the main speakers
- Line input, par. line output
- Integrated bass boost of approx. 3 dB at 40 Hz
- High power reserves

**SAM-300D**

Order No. 0320790

**Class D active subwoofer module, 300 W at 4 Ω**

- High-performance active module in class D technology
- Variable low-pass filter: 40-200 Hz (18 dB)
- Continuously adjustable phase control 0-180° for perfectly matching it to the main speakers
- Line input, par. line output
- Integrated bass boost of approx. 3 dB



- at 40 Hz
- High-level inputs for parallel connection to the speaker cables
- High power reserves

**SAM-500D**

Order No. 0320800

**Class D active subwoofer module, 500 W at 4 Ω**

- High-performance active module in class D technology
- Var. low-pass filter: 40-200 Hz (18 dB)
- Contin, adjustable phase control 0-180° for matching it to main speakers
- Line input, par. line output
- Integrated bass boost of approx. 3 dB at 40 Hz
- High-level inputs for parallel



- connection to the speaker cables
- Very high power reserves for bass speakers



# Contents

01 Pro Line .....	R130
02 Performer Line.....	R132
03 Eco Line .....	R138
04 Accessories for Wireless Systems.....	R142
05 In-ear Monitoring Systems .....	R145
06 Headband Microphones and Lavalier Microphones .....	R146
07 Instrument Mics, Vocal Mics, Studio Mics and Headphones.....	R149
08 Universal Mics, Overhead Mics and Boundary Mics.....	R156
09 Gooseneck Mics, Microphone Floor Stands, Built-in Mics and Desktop Mics.....	R159
10 Accessories for Microphones .....	R162
11 Conference Systems, Microphone Mixers and Interpretation Systems.....	R164
12 Tour Guide Systems.....	R170
Index.....	R175
Important Information .....	R179

All JTS products can also be found online at:  
[www.jts-europe.com](http://www.jts-europe.com)

## JSS-20/5

Order No. 0257200

### Dynamic hand-held UHF PLL transmitter

- Dynamic microphone cartridge (cardioid polar pattern) with minimised feedback susceptibility as well as suppression of handling noise/structure-borne noise
- Bandwidth: 75 MHz
- 15 groups, each with up to 63 compatible preset channels
- 64 channels in 6 groups from 3,000 selectable individual frequencies can be stored in user presets
- REMOSET technology for receiver/transmitter synchronisation
- Adjustable sensitivity (-15 dB to +15 dB)
- Lock function/mute function
- 5-level display for indicating battery status and low battery alert, backlit LCD
- Switchable transmitting power

Model	JSS-20/5
Polar pattern	cardioid
System	dynamic
Carrier frequency range	530-605 MHz
Transmitting power	10/50 mW
Power supply	2 x batt. AA size, alkaline (not supplied)
Operating time	> 20 h
Audio frequency range	50-18,000 Hz
Dimensions	Ø 50 mm x 260 mm
Weight	340 g

- Supplied with robust transport case, stand clamp and 8 ID caps

**There are restrictions or requirements within the EU!**

**Please read the notes regarding wireless systems in the section "IMPORTANT INFORMATION"!**



## UF-20S/5

Order No. 0257220

### Single-channel true diversity UHF PLL wideband receiver

- Bandwidth: 75 MHz
- 15 groups, each with up to 63 compatible preset channels
- 64 channels in 6 groups from 3,000 selectable individual frequencies can be stored in user presets
- REMOSET technology for receiver/transmitter synchronisation
- Auto-scan function
- Pilot tone and noise squelch
- Equalizer function
- LED for indicating RF level and AF level
- Backlit display for indicating battery status of the transmitter, frequency setup, active antenna
- Metal housing
- Power supply for optional antenna booster UB-9001 directly via antenna inputs

Model	UF-20S/5
Description	wireless receiver
Carrier frequency range	530-605 MHz
Audio frequency range	50-18,000 Hz
THD	< 0.5%
Dynamic range	> 108 dB
Audio signal receiver	100 mV XLR, 100 mV jack
Power supply receiver	via encl. power supply
Dimensions receiver	212 x 44 x 214 mm
Weight receiver	1.4 kg
Connections receiver	XLR, bal., 6.3 mm jack, bal.

**There are restrictions or requirements within the EU!**

**Please read the notes regarding wireless systems in the section "IMPORTANT INFORMATION"!**



## UF-20R/5

Order No. 0257210



### 2-channel true diversity UHF PLL wideband receiver

- Bandwidth: 75 MHz
- 15 groups, each with 63 compatible preset channels
- 64 channels in 6 groups from 3,000 selectable individual frequencies can be stored in user presets
- RF output and mains voltage output for easily cascading up to 10 x UF-20R/5 receiver without additional splitter
- REMOSET technology for receiver/transmitter synchronisation
- Auto-scan function
- Pilot tone and noise squelch
- Equalizer function
- LED for indicating RF level and AF level
- Backlit display for indicating battery status of the transmitter, frequency setup, active antenna
- Metal housing

Model	UF-20R/5
Description	wireless receiver
Carrier frequency range	530-605 MHz
Audio frequency range	50-18,000 Hz
THD	< 0.5%
Dynamic range	> 108 dB
Audio signal receiver	100 mV XLR, 100 mV jack
Power supply receiver	~ 100-240 V/50-60 Hz/25 VA
Dimensions receiver	480 x 44 x 214 mm
Weight receiver	2.9 kg
Connections receiver	2 x XLR, bal., 2 x 6.3 mm jack, bal.

- Power supply for optional antenna booster UB-9001 directly via antenna inputs

**There are restrictions or requirements within the EU!**

**Please read the notes regarding wireless systems in the section "IMPORTANT INFORMATION"!**



**UF-20TB/5**

Order No. 0257230

**UHF PLL pocket transmitter**

- Suitable for combination with a headband microphone or an instrument microphone with 4-pole mini XLR connector
- Bandwidth: 75 MHz
- 15 groups, each with up to 63 compatible preset channels
- 64 channels in 6 groups from 3,000 selectable individual frequencies can be stored in user presets
- REMOSET technology for receiver/transmitter synchronisation
- Adjustable sensitivity (-18 dB to +12 dB)
- Lock function
- 5-level display for indicating battery status and low battery alert, backlit LCD
- Switchable transmitting power

Model	UF-20TB/5
Description	pocket transmitter
Carrier frequency range	530-605 MHz
Audio frequency range	50-18,000 Hz
Operating time	> 20 h
Transmitting power	10/50 mW
Power supply transmitter	2 x batt. AA size (not supplied)
Dimensions transmitter	62 x 170 x 23 mm
Weight transmitter	90 g
Connections transmitter	4-pole mini XLR

**There are restrictions or requirements within the EU!**

**Please read the notes regarding wireless systems in the section "IMPORTANT INFORMATION"!**

**CH-8**

Order No. 0259410

**Transport case with integrated charging function**, for transmitters UF-20TB/5, JSS-20/5, JSS-4B/5, R-4TBM/5 and RU-G3TB/5.

- For simultaneously charging rech. batteries of 8 devices
- Average charging time, depending on capacity and condition of rechargeable batteries used: approx. 3 hours
- Each slot with LED for indicating a fault and battery charging status
- Mechanical reverse polarity protection
- Protection against overload, short-circuit and deep discharge
- Power is provided via supplied power supply
- Dimensions: 357 x 294 x 433 mm

Model	CH-8
Description	transport case with integrated charging function
Colour	black
Suitable for	transmitters UF-20TB/5, JSS-20/5, JSS-4B/5, R-4TBM/5, RU-G3TB/5
Power supply	via encl. power supply
Dimensions	357 x 294 x 433 mm
Weight	11.6 kg

**Supplied w/o devices.**

**CH-2**

Order No. 0257240

**Charging station**, for transmitters UF-20TB/5, JSS-20/5, JSS-4B/5, R-4TBM/5 and RU-G3TB/5.

- For simultaneously charging rech. batteries of 2 devices
- Average charging time, depending on condition of rechargeable batteries used: approx. 3 hours
- Each slot with LED for indicating a fault and battery charging status
- Mechanical reverse polarity protection

Model	CH-2
Description	charging station
Colour	black
Suitable for	transmitters UF-20TB/5, JSS-20/5, JSS-4B/5, R-4TBM/5, RU-G3TB/5
Power supply	via enclosed power supply
Dimensions	165 x 72 x 99 mm
Weight	315 g

- Protection against overload, short-circuit and deep discharge
- Power is provided via enclosed power supply
- Dimensions: 165 x 72 x 99 mm

**MA-935**

Order No. 0236850

**Adapter ring**

- For mounting dynamic microphone cartridges from Sennheiser to hand-held UHF PLL transmitters JSS-20/5 and JSS-4B/5
- Aluminium version
- Screw thread

**RTF-UF20**

Order No. 0236880

**PAAR PAIR****BNC antenna cable set**

- For mounting antennas to the front panel of the UHF PLL wideband receiver UF-20R/5 or R-4/5
- 2 x 60 cm antenna cable with BNC plug and BNC inline jack





# Performer Line

## JSS-4B/5

Order No. 0259390

### Dynamic hand-held UHF PLL transmitter

- Dynamic microphone cartridge (cardioid polar pattern) with wide dynamic range
- Aluminium housing
- Bandwidth: 36 MHz
- 6 groups, each with up to 22 compatible preset channels
- 1,441 selectable individual frequencies
- REMOSET technology for receiver/transmitter synchronisation
- Adjustable sensitivity (-15 dB to +15 dB)
- Lock/mute function
- 4-level display for indicating battery status and low battery alert, backlit LCD
- Switchable transmitting power

Model	JSS-4B/5
Transmission method	wireless
Polar pattern	cardioid
System	dynamic
Carrier frequency range	506-542 MHz
Transmitting power	10/50 mW
Power supply	2 x batt. AA size, alkaline (not supplied)
Operating time	> 20 h
Audio frequency range	50-18,000 Hz
Max. sound pressure	150 dB
Housing material	aluminium
Dimensions	Ø 50 mm x 253 mm
Weight	335 g

**There are restrictions or requirements within the EU!**

**Please read the notes regarding wireless systems in the section "IMPORTANT INFORMATION"!**



## R-4THA/5

Order No. 0259847

### Hand-held UHF PLL transmitter, with condenser cartridge.

- Condenser microphone cartridge (cardioid polar pattern)
- Bandwidth: 36 MHz
- 6 groups, each with up to 22 compatible preset channels
- 1,441 selectable individual frequencies
- REMOSET technology for receiver/transmitter synchronisation
- Adjustable sensitivity ( $\pm 15$  dB)
- Lock function/mute function
- 4-level display for indicating battery status and low battery alert, backlit LCD
- Switchable transmitting power

Model	R-4THA/5
Transmission method	wireless
Polar pattern	cardioid
System	condenser
Carrier frequency range	506-542 MHz
Transmitting power	10/50 mW
Power supply	2 x batt. AA size, alkaline (not supplied)
Operating time	> 20 h
Audio frequency range	50-18,000 Hz
Max. sound pressure	140 dB
Dimensions	Ø 50 mm x 253 mm
Weight	260 g

**There are restrictions or requirements within the EU!**

**Please read the notes regarding wireless systems in the section "IMPORTANT INFORMATION"!**



## R-4/5

Order No. 0259400



### 4-channel diversity UHF PLL wideband receiver

- Bandwidth: 36 MHz
- 6 groups, each with up to 22 compatible preset channels
- 1,441 selectable individual frequencies
- RF output and mains voltage output for easily cascading up to 10 x R-4/5 receiver without additional splitter
- REMOSET technology for receiver/transmitter synchronisation
- Auto-scan function
- Pilot tone squelch and noise mute
- LED for indicating RF level and AF level
- Backlit display for indicating battery status of the transmitter, frequency setup, active antenna
- Switchable mic/line for single outputs and mixed outputs
- Metal housing

Model	R-4/5
Description	wireless receiver
Carrier frequency range	506-542 MHz
Audio frequency range	50-18,000 Hz
THD	< 0.6%
Dynamic range	> 105 dB
Audio signal receiver	630 mV/600 $\Omega$ XLR (line), 63 mV/600 $\Omega$ XLR (mic), 320 mV/600 $\Omega$ jack
Power supply receiver	~ 100-240 V/50-60 Hz
Dimensions receiver	485 x 44 x 230 mm
Weight receiver	2.65 kg
Connections receiver	4 x XLR, bal., 1 x XLR, bal., 1 x 6.3 mm jack (mixed out)

**There are restrictions or requirements within the EU!**

**Please read the notes regarding wireless systems in the section "IMPORTANT INFORMATION"!**



## R-4TBM/5

Order No. 0259841

### UHF PLL pocket transmitter

- Suitable for combination with a headband microphone or an instrument microphone with 4-pole mini XLR connector
- Bandwidth: 36 MHz
- 6 groups, each with up to 22 compatible preset channels
- 1,441 selectable individual frequencies
- REMOSET technology for receiver/transmitter synchronisation
- Adjustable sensitivity ( $\pm 15$  dB)
- Lock function
- 6-level display for indicating battery status and low battery alert, backlit LCD
- Switchable transmitting power

Model	R-4TBM/5
Description	pocket transmitter
Carrier frequency range	506-542 MHz
Audio frequency range	50-18,000 Hz
Operating time	> 20 h
Transmitting power	10/50 mW
Operating range	120 m
Power supply transmitter	2 x batt. AA size (not supplied)
Dimensions transmitter	62 x 80 x 23 mm
Weight transmitter	95 g
Connections transmitter	4-pole mini XLR

**There are restrictions or requirements within the EU!**

**Please read the notes regarding wireless systems in the section "IMPORTANT INFORMATION"!**



## CH-2

Order No. 0257240

**Charging station**, for transmitters UF-20TB/5, JSS-20/5, JSS-4B/5, R-4TBM/5 and RU-G3TB/5.

- For simultaneously charging rech. batteries of 2 devices
- Average charging time, depending on condition of rechargeable batteries used: approx. 3 hours
- Each slot with LED for indicating a fault and battery charging status
- Mechanical reverse polarity protection
- Protection against overload, short-circuit and deep discharge
- Power is provided via enclosed power supply
- Dimensions: 165 x 72 x 99 mm

Model	CH-2
Description	charging station
Colour	black
Suitable for	transmitters UF-20TB/5, JSS-20/5, JSS-4B/5, R-4TBM/5, RU-G3TB/5
Power supply	via enclosed power supply
Dimensions	165 x 72 x 99 mm
Weight	315 g



## Performer Line

### RU-G3TH/5

Order No. 0259843

#### Hand-held UHF PLL transmitter with condenser cartridge

- Bandwidth: 36 MHz
- 6 groups, each with up to 22 compatible preset channels
- 1,441 selectable individual frequencies
- REMOSET ULTRASONIC technology for receiver/transmitter synchronisation
- Pilot tone squelch and noise mute
- Lock function/mute function
- Special design to reduce handling noise, structure-borne noise and acoustic feedback
- Backlit LCD for indicating batt. status and low batt alert
- Switchable transmitting power

Model	RU-G3TH/5
Transmission method	wireless
Polar pattern	cardioid
System	condenser
Carrier frequency range	506-542 MHz
Transmitting power	10/50 mW
Power supply	2 x batt. AA size, alkaline (not supplied)
Audio frequency range	50-18,000 Hz
Max. sound pressure	140 dB
Dimensions	Ø 50 mm x 253 mm
Weight	780 g

**There are restrictions or requirements within the EU!**

**Please read the notes regarding wireless systems in the section "IMPORTANT INFORMATION"!**



### RU-G3TB/5

Order No. 0259842

#### UHF PLL pocket transmitter

- Suitable for combination with a headband microphone or an instrument microphone with 4-pole mini XLR connector
- Bandwidth: 36 MHz
- 6 groups, each with up to 22 compatible preset channels
- 1,441 selectable individual frequencies
- REMOSET ULTRASONIC technology for receiver/transmitter synchronisation
- Backlit LCD for indicating battery status and low battery alert
- Switchable transmitting power

Model	RU-G3TB/5
Description	pocket transmitter
Carrier frequency range	506-542 MHz
Audio frequency range	50-18,000 Hz
Operating time	12 h
Transmitting power	10/50 mW
Power supply transmitter	2 x battery AA size, alkaline (not supplied)
Dimensions transmitter	62 x 80 x 23 mm
Weight transmitter	300 g
Connections transmitter	4-pole mini XLR

**There are restrictions or requirements within the EU!**

**Please read the notes regarding wireless systems in the section "IMPORTANT INFORMATION"!**



### RU-901G3/5

Order No. 0259844

#### True diversity UHF PLL wideband receiver

- Bandwidth: 36 MHz
- 6 groups, each with up to 22 compatible preset channels
- 1,441 selectable individual frequencies
- REMOSET ULTRASONIC technology for receiver/transmitter synchronisation
- Removable antennas (BNC connection)
- Auto-scan function
- Pilot tone squelch and noise mute
- LED for indicating RF level and AF level
- Backlit display with status indications, e.g. group/channel, frequency, battery, antenna A/B

Model	RU-901G3/5
Description	receiver unit
Carrier frequency range	506-542 MHz
Audio frequency range	50-18,000 Hz
THD	< 0.6%
Dynamic range	105 dB
Audio signal receiver	630 mV/600 Ω XLR (line), 63 mV/600 Ω XLR (mic), 320 mV/600 Ω jack
Power supply receiver	via encl. power supply
Dimensions receiver	212 x 38 x 144 mm
Weight receiver	1.02 kg
Connections receiver	1 x XLR, bal., 1 x 6.3 mm jack, unbal.

**There are restrictions or requirements within the EU!**

**Please read the notes regarding wireless systems in the section "IMPORTANT INFORMATION"!**



### G3CH-2

Order No. 0259839

#### Charging station, for transmitters RU-G3TH/5, RU-G3TB/5, R-4TBM/5 and UF-20TB/5.

- For simultaneously charging rech. batt. of 2 devices
- Average charging time, depending on condition of rechargeable batteries used: approx. 5 hours
- Each slot with LED for indicating a fault and battery charging status
- Mechanical reverse polarity protection
- Protection against overload, short-circuit and deep discharge

Model	G3CH-2
Description	charging station
Colour	black
Suitable for	transmitters RU-G3TH/5, RU-G3TB/5, R-4TBM/5, UF-20TB/5
Power supply	via encl. power supply
Dimensions	165 x 72 x 99 mm
Weight	323 g

- Power is provided via enclosed power supply
  - Dimensions: 165 x 72 x 99 mm
- Supplied w/o devices**



## MH-8800G/5

Order No. 0255450

### Dynamic hand-held UHF PLL transmitter

- Preset technology for easy configuration (64 channels)
- Pilot tone technology
- Adjustable sensitivity (0 dB to -30 dB)
- Lock function
- Special design to reduce handling noise, structure-borne noise and acoustic feedback
- Robust body
- Integrated LCD with battery status indication
- Supplied with robust transport case, colour-coded ID rings and stand clamp

Model	MH-8800G/5
Polar pattern	hypercardioid
System	dynamic
Carrier frequency range	518-542 MHz
Transmitting power	50 mW
Power supply	2 x batt. AA size, alkaline (not supplied)
Operating time	> 25 h
Audio frequency range	50-16,000 Hz
Dimensions	Ø 53 mm x 245 mm
Weight	370 g

**There are restrictions or requirements within the EU!**

**Please read the notes regarding wireless systems in the section "IMPORTANT INFORMATION"!**



## PT-920BG/5

Order No. 0255490

### UHF PLL pocket transmitter with lavalier microphone

- Suitable for instrument microphones of the CX series and headband microphones or lavalier microphones from the CX/CM series
- Supplied with lavalier microphone CM-501
- 64 preset channels
- Pilot tone technology
- Continuously adjustable gain
- Lock function
- Integrated LCD for indicating battery status and transmission data
- Supplied with belt bag and robust transport case

Model	PT-920BG/5
Description	pocket transmitter
Carrier frequency range	518-542 MHz
Audio frequency range	40-18,000 Hz
Operating time	> 30 h
Transmitting power	10 mW
Power supply transmitter	2 x batt. AA size, alkaline (not supplied)
Dimensions transmitter	70 x 190 x 30 mm
Weight transmitter	130 g
Connections transmitter	4-pole mini XLR

**There are restrictions or requirements within the EU!**

**Please read the notes regarding wireless systems in the section "IMPORTANT INFORMATION"!**



## US-903DCPRO/5

Order No. 0255570

### 2-channel diversity UHF PLL receiver

- 2 x 64 channel presets in four groups
- Parallel operation of up to 8 frequencies (equivalent to 4 x 2-channel system)
- Pilot tone squelch and adjustable noise squelch
- Lock function
- Backlit LCD for indicating status, e.g. for channel/group assignment and RF level/AF level
- Integrated charging slot for 4 x rechargeable NiMH battery AA size with indication of operating status
- Robust desktop metal housing
- Power supply for optional antenna booster UB-9001 directly via antenna inputs
- 482 mm (19") rack installation with supplied mounting brackets

Model	US-903DCPRO/5
Description	receiver unit
Carrier frequency range	518-542 MHz
Audio frequency range	40-18,000 Hz
THD	< 0.6%
Dynamic range	> 105 dB
Audio signal receiver	40 mV XLR, 250 mV jack
Power supply receiver	via encl. power supply
Dimensions receiver	420 x 50 x 230 mm
Weight receiver	2.25 kg
Connections receiver	2 x XLR, bal. 1 x 6,3 mm jack, unbal.

**There are restrictions or requirements within the EU!**

**Please read the notes regarding wireless systems in the section "IMPORTANT INFORMATION"!**



## Performer Line

### RU-8011DB/5

Order No. 0259200

#### Diversity UHF PLL wideband receiver

- Bandwidth: 36 MHz
- 6 groups, each with up to 22 compatible preset channels
- 1,441 selectable individual frequencies
- REMOSET ULTRASONIC technology for receiver/transmitter synchronisation
- Removable antennas (BNC connection)
- Auto-scan function
- Pilot tone squelch and noise mute

Model	RU-8011DB/5
Description	receiver unit
Carrier frequency range	506-542 MHz
Audio frequency range	50-16,000 Hz
THD	< 0.6%
Dynamic range	> 105 dB
Audio signal receiver	630 mV/600 Ω XLR (line), 63 mV/600 Ω XLR (mic), 320 mV/600 Ω jack
Power supply receiver	via encl. power supply
Dimensions receiver	210 x 40 x 185 mm
Weight receiver	457 g
Connections receiver	1 x XLR, bal., 1 x 6.3 mm jack, unbal.



### RU-8011D/5

Order No. 0259848

#### Diversity UHF PLL wideband receiver

- Bandwidth: 36 MHz
- 6 groups, each with up to 22 compatible preset channels (114 channels)
- REMOSET ULTRASONIC technology for receiver/transmitter synchronisation
- Auto-scan function
- Pilot tone squelch and noise mute

Model	RU-8011D/5
Description	receiver unit
Carrier frequency range	506-542 MHz
Audio frequency range	60-15,000 Hz
THD	< 0.6%
Dynamic range	> 105 dB
Audio signal receiver	630 mV/600 Ω XLR (line), 63 mV/600 Ω XLR (mic), 320 mV/600 Ω jack
Power supply receiver	via encl. power supply
Dimensions receiver	210 x 40 x 180 mm
Weight receiver	440 g
Connections receiver	1 x XLR, bal., 1 x 6.3 mm jack, unbal.



### RU-8012DB/5

Order No. 0259420

#### 2-channel diversity UHF PLL wideband receiver

- Bandwidth: 36 MHz
- 6 groups, each with up to 22 compatible preset channels
- 1,441 selectable individual frequencies
- REMOSET ULTRASONIC technology for receiver/transmitter synchronisation
- Removable antennas (BNC connection)
- Auto-scan function
- Pilot tone squelch and noise mute

Model	RU-8012DB/5
Description	receiver unit
Carrier frequency range	506-542 MHz
Audio frequency range	50-16,000 Hz
THD	< 0.6%
Dynamic range	> 105 dB
Audio signal receiver	630 mV/600 Ω XLR (line), 63 mV/600 Ω XLR (mic), 320 mV/600 Ω jack
Power supply receiver	via encl. power supply
Dimensions receiver	210 x 40 x 185 mm
Weight receiver	508 g
Connections receiver	2 x XLR, bal., 2 x 6.3 mm jack, unbal.



### 850CH-2

Order No. 0259370

**Charging station**, for transmitters RU-850LTH/5, RU-850LTB/5 and R-4THA/5.

- For simultaneously charging rech. batteries of 2 devices
- Average charging time, depending on condition of rechargeable batteries used: approx. 5 hours
- Each slot with LED for indicating a fault and battery charging status
- Mechanical reverse polarity protection
- Protection against overload, short-circuit and deep discharge

Model	850CH-2
Description	charging station
Colour	black
Suitable for	transmitters RU-850LTH/5, RU-850LTB/5, R-4THA/5
Power supply	via encl. power supply
Dimensions	165 x 72 x 99 mm
Weight	329 g

- Power is provided via enclosed power supply
  - Dimensions: 165 x 72 x 99 mm
- Supplied w/o devices.**





## RU-850LTH/5

Order No. 0259560

### Dynamic hand-held UHF PLL microphone transmitter

- Bandwidth: 36 MHz
- 6 groups, each with up to 22 compatible preset channels
- 1,441 selectable individual frequencies
- REMOSET ULTRASONIC technology for receiver/transmitter synchronisation
- Adjustable sensitivity ( $\pm 15$  dB)
- Lock function/mute function
- 5-level display for indicating battery status and low battery alert, backlit LCD

Model	RU-850LTH/5
Transmission method	wireless
Polar pattern	cardioid
System	dynamic
Carrier frequency range	506-542 MHz
Transmitting power	10/50 mW
Power supply	2 x batt. AA size, alkaline (not supplied)
Operating time	30 h
Audio frequency range	50-16,000 Hz
Max. sound pressure	148 dB
Dimensions	$\varnothing 51$ mm x 269 mm
Weight	242 g

- Switchable transmitting power



## RU-850LTB/5

Order No. 0259360

### UHF PLL pocket transmitter

- Suitable for combination with a headband microphone or an instrument microphone with 4-pole mini XLR connector
- Bandwidth: 36 MHz
- 6 groups, each with up to 22 compatible preset channels
- 1,441 selectable individual frequencies
- REMOSET ULTRASONIC technology for receiver/transmitter synchronisation
- Selectable sensitivity ( $\pm 15$  dB); additional 20 dB attenuation can be activated as required

Model	RU-850LTB/5
Description	pocket transmitter
Carrier frequency range	506-542 MHz
Audio frequency range	50-16,000 Hz
Operating time	30 h
Transmitting power	10/50 mW
Power supply transmitter	2 x batt. AA size, alkaline (not supplied)
Dimensions transmitter	62 x 97 x 20 mm
Weight transmitter	76 g
Connections transmitter	4-pole mini XLR

- Lock/mute function
- 5-level display for indicating battery status and low battery alert, backlit LCD
- Switchable transmitting power



## RU-850TH/5

Order No. 0259851

### Dynamic hand-held UHF PLL microphone transmitter

- Bandwidth: 36 MHz
- 6 groups, each with 22 compatible preset channels (114 channels)
- REMOSET ULTRASONIC technology for receiver/transmitter synchronisation
- Sensitivity adjustment ( $\pm 15$  dB) and transmitting power (10/50 mW) can be configured via receiver
- Special design to reduce handling noise, structure-borne noise and acoustic feedback

Model	RU-850TH/5
Transmission method	wireless
Polar pattern	cardioid
System	dynamic
Carrier frequency range	506-542 MHz
Transmitting power	10/50 mW
Power supply	2 x batt. AA size, alkaline (not supplied)
Operating time	30 h
Audio frequency range	60-15,000 Hz
Max. sound pressure	148 dB
Dimensions	$\varnothing 51$ mm x 269 mm
Weight	235 g

- Mute function
- Low battery alert



## RU-850TB/5

Order No. 0259849

### UHF PLL pocket transmitter

- Suitable for combination with a headband microphone or an instrument microphone with 4-pole mini XLR connector
- Bandwidth: 36 MHz
- 6 groups, each with up to 22 compatible preset channels (114 channels)
- REMOSET ULTRASONIC technology for receiver/transmitter synchronisation
- Sensitivity ( $\pm 15$  dB), additional 20 dB attenuation and transmitting power (10/50 mW) can be configured via receiver

Model	RU-850TB/5
Description	pocket transmitter
Carrier frequency range	506-542 MHz
Audio frequency range	60-15,000 Hz
Operating time	30 h
Transmitting power	10/50 mW
Power supply transmitter	2 x batt. AA size, alkaline (not supplied)
Dimensions transmitter	62 x 97 x 20 mm
Weight transmitter	69 g
Connections transmitter	4-pole mini XLR

- Mute function
- Low battery alert



**There are restrictions or requirements in the EU!**

**Please read the notes on wireless systems in the section "IMPORTANT INFORMATION"!**

## E-7TH/5

Order No. 0259618

### Hand-held UHF PLL condenser transmitter

- 16 channels
- Mute function
- 7-segment channel indicator
- LED indicators for power, battery status and mute

**There are restrictions or requirements within the EU!**

**Please read the notes regarding wireless systems in the section "IMPORTANT INFORMATION"!**

Model	E-7TH/5
Polar pattern	hypercardioid
System	condenser
Carrier frequency range	506-542 MHz
Transmitting power	10 mW
Power supply	2 x batt. AA size, alkaline (not supplied)
Audio frequency range	50-16,000 Hz



## E-7HHSET/5

Order No. 0259614

### UHF PLL audio transmission set,

consisting of:

- Diversity UHF PLL receiver E-7R/5
- Hand-held UHF PLL condenser transmitter E-7TH/5

Carrier frequency range: 504-542 MHz

For specifications, please refer to the individual items.

**There are restrictions or requirements within the EU!**

**Please read the notes regarding wireless systems in the section "IMPORTANT INFORMATION"!**



## E-7HHSETD/5

Order No. 0259613

### UHF PLL audio transmission set,

consisting of:

- 2-channel diversity UHF PLL receiver E-7DU/5
- Hand-held UHF PLL condenser transmitter (set of 2) E-7THD/5

Carrier frequency range: 504-542 MHz

For specifications, please refer to the individual items.

**There are restrictions or requirements within the EU!**

**Please read the notes regarding wireless systems in the section "IMPORTANT INFORMATION"!**



**E-7TB/5**

Order No. 0259621

**UHF PLL pocket transmitter with lavalier microphone**

- Suitable for instrument microphones of the CX series as well as headband microphones of the CX/CM series
- Supplied with lavalier microphone CM-501
- 16 channels
- Mute function
- 7-segment channel indicator
- LED indicators for power, battery status and mute

**There are restrictions or requirements within the EU!**

**Please read the notes regarding wireless systems in the section "IMPORTANT INFORMATION"!**

Model	E-7TB/5
Description	pocket transmitter
Carrier frequency range	506-542 MHz
Audio frequency range	40-18,000 Hz
Operating time	> 30 h
Transmitting power	10 mW
Power supply transmitter	2 x batt. AA size, alkaline (not supplied)
Connections transmitter	4-pole mini XLR

**E-7BPSET/5**

Order No. 0259612

**UHF PLL audio transmission set,**

consisting of:

- Diversity UHF PLL receiver E-7R/5
- UHF PLL pocket transmitter with lavalier microphone E-7TB/5

Carrier frequency range: 504-542 MHz

For specifications, please refer to individual items.

**There are restrictions or requirements within the EU!**

**Please read the notes regarding wireless systems in the section "IMPORTANT INFORMATION"!**

**E-7BPSETD/5**

Order No. 0259611

**UHF PLL audio transmission set,**

consisting of:

- 2-channel diversity UHF PLL receiver E-7DU/5
- UHF PLL pocket transmitter with lavalier microphone (set of 2) E-7TBD/5

Carrier frequency range: 504-542 MHz

For specifications, please refer to individual items.

**There are restrictions or requirements within the EU!**

**Please read the notes regarding wireless systems in the section "IMPORTANT INFORMATION"!**



## MH-850/1

Order No. 0254460

### Dynamic hand-held UHF PLL microphone transmitter

- 16 channels
- Pilot tone technology
- Special design to reduce handling noise, structure-borne noise and acoustic feedback
- Integrated low battery alert

Licence-free in the EU.

Model	MH-850/1
Polar pattern	hypercardioid
System	dynamic
Carrier frequency range	863-865 MHz
Transmitting power	10 mW
Power supply	2 x batt. AA size, alkaline (not supplied)
Operating time	25 h max.
Audio frequency range	50-16,000 Hz
Dimensions	Ø 55 mm x 260 mm
Weight	250 g



## US-8001D/1

Order No. 0254480

### Diversity UHF PLL receiver

- 16 channels
- Parallel operation of up to 4 intermodulation-free frequencies
- Pilot tone squelch and fixed noise squelch
- LEDs for indicating diversity status and AF level
- 482 mm (19") unit holder DR-900SET for 1 RS rack installation of 2 x US-8001D/1 is available at option

Licence-free in the EU.

Model	US-8001D/1
Description	receiver unit
Carrier frequency range	863-865 MHz
Audio frequency range	40-18,000 Hz
THD	< 0.6%
Dynamic range	> 105 dB
Audio signal receiver	40 mV XLR, 150 mV jack
Power supply receiver	via encl. power supply
Dimensions receiver	210 x 40 x 170 mm
Weight receiver	455 g
Connections receiver	1 x XLR, bal., 1 x 6.3 mm jack, unbal.



## US-8002D/1

Order No. 0254490

### Diversity UHF PLL receiver

- 2 x 16 channels
- Parallel operation of up to 4 intermodulation-free frequencies
- Pilot tone squelch and fixed noise squelch
- LEDs for indicating diversity status and AF level
- 482 mm (19") unit holder DR-900SET for 1 RS rack installation of 2 x US-8002D/1 is available at option

Licence-free in the EU.

Model	US-8002D/1
Description	receiver unit
Carrier frequency range	863-865 MHz
Audio frequency range	40-18,000 Hz
THD	< 0.6%
Dynamic range	> 105 dB
Audio signal receiver	40 mV XLR, 150 mV jack
Power supply receiver	via encl. power supply
Dimensions receiver	210 x 40 x 170 mm
Weight receiver	500 g
Connections receiver	2 x XLR, bal., 1 x 6.3 mm jack, unbal.



**PT-850B/1**

Order No. 0254470

**UHF PLL pocket transmitter with lavalier microphone**

- Suitable for instrument microphones of the CX series as well as headband microphones of the CX/CM series
- Supplied with lavalier microphone CM-501
- 16 preset channels
- Continuously adjustable gain
- Dual LED for indicating battery status
- Supplied with belt bag

**Licence-free in the EU.**

Model	PT-850B/1
Description	pocket transmitter
Carrier frequency range	863-865 MHz
Audio frequency range	40-18,000 Hz
Operating time	25 h max.
Transmitting power	10 mW
Power supply transmitter	2 x batt. AA size, alkaline (not supplied)
Dimensions transmitter	70 x 190 x 30 mm
Weight transmitter	120 g
Connections transmitter	4-pole mini XLR

**US-8001DBGY/5**

Order No. 0259846

**UHF PLL audio transmission set**

Consisting of:

- Diversity UHF PLL receiver US-8001DB/5
- Headband microphone with integrated 16-channel PLL transmitter UT-16HW5

For specifications, please refer to individual items.

**There are restrictions or requirements within the EU!****Please read the notes regarding wireless systems in the section "IMPORTANT INFORMATION"!**

Model	US-8001DBGY/5
Description	UHF PLL audio transmission set
Carrier frequency range	518-542 MHz
Audio frequency range	40-18,000 Hz
THD	< 0.5%
Dynamic range	> 105 dB
Power supply transmitter	1 x 1.5 V AAA size (not supplied)
Weight transmitter	50 g
Audio signal receiver	40 mV XLR, 150 mV jack
Power supply receiver	via encl. power supply
Dimensions receiver	210 x 40 x 181 mm
Weight receiver	565 g
Connections receiver	1 x XLR, bal., 1 x 6.3 mm jack, unbal.



## UDA-49A

Order No. 0150630

### Active UHF directional antenna

- Improved reception and a larger transmission range of 470-960 MHz
- Rejects unwanted RF signals, minimises signal loss in multipath receptions and reduces interference susceptibility
- Reliable operation also for short-term outdoor use
- Switchable gain (3 dB/10 dB) to avoid power loss
- Power supply via UHF PLL receivers of the US/IN series or the active antenna splitter UA-960
- Ideally suited for mobile applications, can be mounted onto any microphone stand with a thread of 9 mm (3/8") or 16 mm (5/8")

Model	UDA-49A
Frequency range	470-960 MHz
Aperture angle	100°
Antenna gain	≥ 10 dB
Power supply	= 12 V/50 mA, remote power supply (external power supply)
Impedance level	50 Ω
Support	9 mm (3/8") or 16 mm (5/8")
Dimensions	360 x 350 x 36 mm (sheet thickness: 1.7 mm)
Weight	350 g
Connection	BNC jack

**2 x UDA-49A required for diversity reception.**



## UDA-49P

Order No. 0150640

### Passive UHF directional antenna

- For wireless microphone systems (reception antenna) or for wireless in-ear monitoring systems, e.g. SIEM-111/5 from JTS (transmitting antenna)
- Improved reception and a larger transmission range of 470-960 MHz
- Rejects unwanted RF signals, minimises signal loss in multipath receptions and reduces interference susceptibility
- Reliable operation also for short-term outdoor use
- BNC connection (for UHF PLL receivers of the US/IN series or active antenna splitter UA-960)
- Ideally suited for mobile applications, can be mounted onto any microphone stand with a thread of 9 mm (3/8") or 16 mm (5/8")

Model	UDA-49P
Frequency range	470-960 MHz
Aperture angle	100°
Antenna gain	≥ 10 dB
Impedance level	50 Ω
Support	9 mm (3/8") or 16 mm (5/8")
Dimensions	360 x 350 x 36 mm (sheet thickness: 1.7 mm)
Weight	350 g
Connection	BNC jack

**2 x UDA-49P required for diversity reception.**



## ANT-49

Order No. 0150810

### Passive UHF wideband omnidirectional antenna

- For wireless microphone systems or wireless in-ear monitoring systems
- Consistent RF power supply, independent of direction
- Ideally suited for mobile applications, can be mounted onto microphone stand with 9 mm (3/8") or 16 mm (5/8") thread

Model	ANT-49
Frequency range	470-960 MHz
Aperture angle	360°
Antenna gain	2-4 dB
Impedance level	50 Ω
Support	9 mm (3/8") or 16 mm (5/8")
Dimensions	130 x 255 x 32 mm (sheet thickness: 2 mm)
Weight	205 g
Connection	BNC jack

**2 x ANT-49 required for diversity reception.**



## USP-900

Order No. 0150650

### Passive UHF antenna splitter/UHF combiner

- For minimising the great effort and expense of antennas for wireless receiver systems or transmission systems
- Splits one antenna input signal to two antenna output signals
- 2 x USP-900 required for commonly supplying two diversity receivers set up with two antennas respectively

Model	USP-900
Frequency range	10-1,000 MHz
Launch attenuation	2 dB
Decoupling	20 dB
Impedance level	50 Ω
Connection	3 x BNC jack
Dimensions	72 x 24 x 56 mm
Weight	63 g

- DC suppression
- Can also be used as a combiner in order to operate 2 x SIEM-111/5 with one antenna





## UA-960

Order No. 0150820



### Active antenna splitter

- For operating up to four UHF PLL receivers of the UF/US/IN series with one pair of antennas
- With this device, it is not longer required to use the respective antennas and plug-in power supplies of the individual devices
- Frequency range: 470-960 MHz
- Power supply via four low-voltage outputs (4 x = 12 V/1 A max.)

- Each antenna to be connected via BNC jacks
- Additional connection for cascading further antenna splitters
- Supplied with suitable connection cables
- Power supply for optional antenna booster UB-900I directly via UA-960 (can be deactivated internally)



## UC-900

Order No. 0150580



### 4-way antenna combiner

- Range of applications:
  - Signals of up to four in-ear monitoring transmitters, e.g. SIEM-111/..., can be sent via one antenna
  - Signals of up to four antennas which are positioned at a certain distance from each other can be combined for extending the reception area of a stationary receiver
- Frequency range: 470-960 MHz

- Gain: 0 dB, ±2 dB
- Maximum RF power for each input: +20 dBm (100 mW)
- Low-voltage outputs: 4 x = 12 V, 1 A max. for supplying operating voltage directly to connected transmitter
- Each antenna to be connected via BNC jacks
- Supplied with suitable connection cables



## USP-124

Order No. 0150860

### 4-way antenna splitter

- For operating up to four antennas with one transmitter (e.g. SIEM-111/5)
- Frequency range: 470-960 MHz
- Gain: 0 dB, ± 2 dB
- All connections via BNC jacks



## UB-900I

Order No. 0150830

### Antenna booster, for UHF PLL receivers.

- Power supply via UHF PLL receivers of the UF/US series and IN series or via active antenna splitter UA-960
- DC feed-through output for cascading up to 2 x UB-900I max.
- Ideally suited for mobile applications, can be mounted onto microphone stand with 16 mm (5/8") thread



**Diversity operation: one booster is required for each antenna connected!**

## RP-900

Order No. 0230540

### Mounting plate, for offset antenna mounting.

- Black lacquered metal version
- Dimensions: 227 x 44 x 1.6 mm, 1 RS

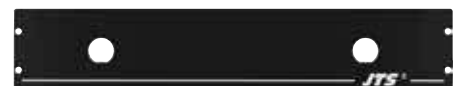

## RTF-20

Order No. 0252060

**Coaxial antenna cable**, with mounting plate.

- 2 x 20 m RG-58U coaxial cable with 2 x BNC plug each, e.g. for connecting offset antennas to respective UHF PLL receivers of the UF/US/IN series or in-ear monitoring transmitter SIEM-111/R
- Mounting plate (1 RS) with punched holes for two supplied BNC bushings

Model	RTF-20
Intended use	coaxial antenna cable
Connectors	2 x BNC plug
Length	20 m
Colour	black
Cable diameter	5 mm
Shielding value	20 dB @ 100 MHz
Impedance	50 Ω
Attenuation	7 dB
Special feature	1 RS mounting plate: 227 x 44 x 1.6 mm
Other features	frequency range: 10-1,000 MHz



## RTF-2U

Order No. 0230530



**Mounting bracket set**, for offset antenna mounting.

- For 482 mm (19") rack installation
- Consisting of:
  - 2 x mounting bracket
  - 2 x BNC jack
  - 2 x 40 cm antenna cable with BNC plug

Model	RTF-2U
Size	for 482 mm (19")
Colour	black
Weight	105 g (pair)



## DR-900SET

Order No. 0244770

**482 mm (19", 1 RS) device holder**

- For installing up to two half-rack sized receivers into one 482 mm (19") rack
- Partly profiled sheet steel for on-the-road applications and secure support
- The supplied 241 mm (9.5") rack panel with screws can cover the unrequired mounting space



## RTF-1

Order No. 0230550

**Coaxial antenna cable**, with mounting plate.

- 2 x 0.6 m RG-58U coaxial cable with 2 x BNC plug each, e.g. for connecting offset antennas to respective UHF PLL receivers of the UF/US/IN series or in-ear monitoring transmitter SIEM-111/R



## RTF-3

Order No. 0230560



**BNC antenna cable**

- 50 Ω
- 2 x BNC plug
- Length: 2 x 3 m
- 2 x BNC bushing



## RM-901

Order No. 0254940



**482 mm (19") mounting brackets**

- For mounting CS-4, CS-8, SIEM-111/... (transmitter), TG-10STX/1, UF-10R/12, UF-20S/5 or US-9001D/... into a rack cabinet
- Metal version

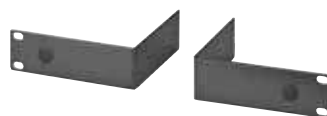

## RM-10SET

Order No. 0254950

**482 mm (19") mounting set**

- For mounting two SIEM-111/... (transmitter), UF-10R/12 or UF-20S/5 into a rack cabinet
- Consisting of two metal mounting brackets and two aluminium connecting rails



## SIEM-111/5

Order No. 0255510

### MPX stereo UHF PLL in-ear monitoring system

- Wireless monitor system with excellent sound characteristics
- Individual monitor mix in stereo mode or mono/mix mode
- 64 preset channels in 4 groups of 16 channels each
- 961 frequencies
- Up to 14 wireless monitor ways can be used for an intermodulation-free parallel operation
- Pilot tone technology and noise squelch

Model	SIEM-111/5
Description	in-ear monitoring system
Carrier frequency range	518-542 MHz
Audio frequency range	50-15,000 Hz
Total weight	2.33 kg
Transmitting power	10 mW
Power supply transmitter	~ 100-240 V via integrated switch-mode power supply
Dimensions transmitter	212 x 44 x 239 mm
Weight transmitter	1.3 kg
Connections transmitter	2 x combo input, 2 x loop output, bal. via 6.3 mm jack
Power supply receiver	2 x batt. AA size, alkaline (not supplied)
Dimensions receiver	74 x 196 x 34 mm
Weight receiver	300 g
Connections receiver	3.5 mm stereo jack



## SIEM-111/R5

Order No. 0255520

**UHF PLL in-ear monitoring receiver**, as an addition to the in-ear monitoring system SIEM-111/5.

- Excellent audio characteristics
- Pilot tone technology
- Peak limiter, can be activated as required
- Individual monitor mix in stereo mode or mono/mix mode
- Ear-selective level matching possible via balance adjustment

Model	SIEM-111/R5
Description	in-ear monitoring receiver
Carrier frequency range	518-542 MHz
Audio frequency range	50-15,000 Hz
THD	0.8%
Dynamic range	> 80 dB
Operating time	> 8 h
Power supply receiver	2 x batt. AA size, alkaline (not supplied)
Dimensions receiver	74 x 196 x 34 mm
Weight receiver	202 g
Connections receiver	3.5 mm stereo jack



## SIEM-2/5

Order No. 0255530

### Mono UHF PLL in-ear monitoring system

- 16 preset channels
- Integrated limiter
- Loop outputs on the rear panel
- Switchable transmitting power
- Supplied with high-quality in-ear earphones IE-1
- 482 mm (19") rack installation

Model	SIEM-2/5
Description	in-ear monitoring system
Carrier frequency range	518-542 MHz
Audio frequency range	40-18,000 Hz
Operating time	> 8 h
Transmitting power	10/50 mW
Power supply transmitter	~ 100-240 V via encl. plug-in power supply
Dimensions transmitter	210 x 42 x 180 mm
Weight transmitter	460 g
Connections transmitter	2 x combo (in) 2 x 6.3 mm jack, bal. (loop out)
Power supply receiver	2 x batt. AA size, alkaline (not supplied)
Dimensions receiver	75 x 160 x 32 mm
Weight receiver	90 g
Connections receiver	6.3 mm stereo jack



## SIEM-2/R5

Order No. 0255540

**Mono UHF PLL in-ear monitoring receiver**, as an addition to in-ear monitoring system SIEM-2/5.

- Switchable limiter
- Separate adjustable mic/line input
- Phantom power supply: 4 V
- Low battery alert
- Belt clip

Model	SIEM-2/R5
Description	in-ear monitoring receiver
Carrier frequency range	518-542 MHz
Audio frequency range	40-18,000 Hz
Dynamic range	> 80 dB
Operating time	> 8 h
Power supply receiver	2 x batt. AA size, alkaline (not supplied)
Dimensions receiver	75 x 160 x 32 mm
Weight receiver	83 g
Connections receiver	6.3 mm stereo jack



## IE-1

Order No. 0220810

### Stereo in-ear earphones

- Esp. designed for application with in-ear systems SIEM
- Musical experience rich in detail due to a brilliant reproduction of the high frequencies, a natural midrange and a reproduction of the entire bass range
- Three pairs of silicone sleeves in different sizes ensure an excellent isolation of the background noise and a perfect fit, very comfortable to wear without pressure even after hours of wearing

Model	IE-1
Type of transducer	dynamic
Max. input power	100 mW
Transmission range, headphones	20-20,000 Hz
Nominal impedance, headphones	16 Ω
Headphone sensitivity	114 dB/mW
Cable	1.5 m
Plug	3.5 mm stereo plug
Weight w/o cable	6 g



# Headband Microphones and Lavalier Microphones

## CM-235IF

Order No. 0235970

### Electret headband microphone

- High-quality microphone cartridge with omnidir. polar pattern
- Very comfortable to wear
- Adjustable headband
- Replaceable connection cable
- Suitable for children
- Highly flexible gooseneck cartridge arm
- Drip ring (protects cartridge from moisture)
- 4-pole mini XLR inline jack for connection to pocket transmitters of the IN/PT/UF, other connection cables are available at option

Model	CM-235IF
Polar pattern	omnidir.
System	electret
Audio frequency range	50-18,000 Hz
Nominal impedance	1.8 k $\Omega$
Sensitivity	2.2 mV/Pa
Max. sound pressure	130 dB
Power supply	pocket transmitter IN/PT/UF series or PS-500
Weight	17 g
Connection	4-pole mini XLR (optional: 3.5 mm stereo plug, 3-pole mini XLR or 4-pole Hirose connector)

- Supplied with bag and windshield

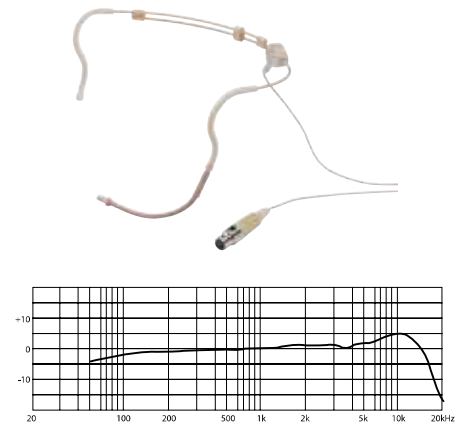

## CM-214F

Order No. 0236430

### Electret headband microphone

- Omnidirectional polar pattern allows for microphone to be positioned slightly next to the mouth in an unobtrusive way instead of directly in front of the mouth
- Ultra-light and adjustable headband
- Replaceable connection cable
- Secure fit, very comfortable to wear
- Drip ring protects cartridge from moisture and ensures a long operating life
- For connection to the pocket transmitters of the IN/PT/UF series with 4-pole mini XLR connection cable
- Other connection cables are available at option

Model	CM-214F
Polar pattern	omnidir.
System	electret
Audio frequency range	60-15,000 Hz
Nominal impedance	2.2 k $\Omega$
Sensitivity	10 mV/Pa
Max. sound pressure	130 dB
Power supply	pocket transmitter IN/PT/UF series or PS-500
Weight	40 g
Connection	cable with 4-pole mini XLR (optional 3.5 mm stereo plug, 3-pole mini XLR or 4-pole Hirose connector)

- Supplied with bag and windshield

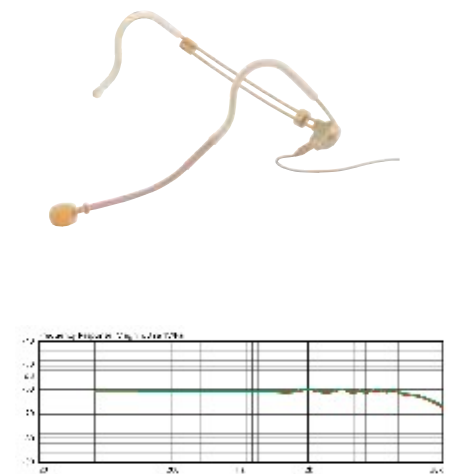

## CM-214ULF

Order No. 0236450

### Electret headband microphone

- Transparent sound
- Adjustable headband, comfortable to wear
- Highly resistant to acoustic feedback due to cardioid polar pattern
- Replaceable connection cable
- Flexible cartridge arm for exact positioning of cartridge, thus providing an optimum sound with an unobtrusive appearance
- Integrated drip ring protects the cartridge from moisture
- Supplied with a 4-pole mini XLR connection cable for connection to pocket transmitters of the IN/PT/UF series

Model	CM-214ULF
Polar pattern	cardioid
System	electret
Audio frequency range	100-18,000 Hz
Nominal impedance	1.5 k $\Omega$
Sensitivity	1.8 mV/Pa
Max. sound pressure	120 dB
Power supply	pocket transmitter IN/PT/UF series or PS-500
Weight	44 g
Connection	4-pole mini XLR (optional: 3.5 mm stereo plug, 3-pole mini XLR or 4-pole Hirose connector)

- Connection cable with strain relief, screwed-on
- Other connection cables are available at option
- Supplied with bag and windshield

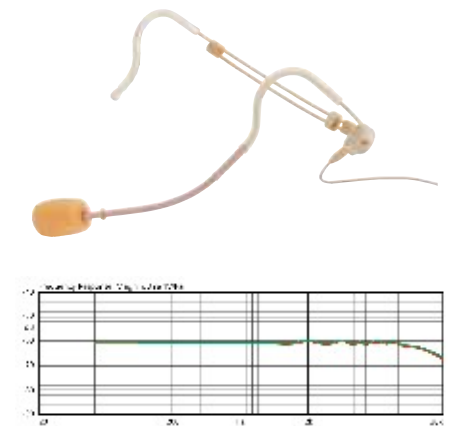

## CM-804IF

Order No. 0236090

### Electret headband microphone

- Lightweight, very comfortable to wear, expressive sound
- Adjustable neckband, lockable
- Integrated drip ring protects cartridge from moisture
- Folding ear hook
- Connection cable with strain relief, screwed-on
- Other connection cables are available at option
- Supplied with bag, windshield and collar clip

Model	CM-804IF
Polar pattern	omnidir.
System	electret
Audio frequency range	60-15,000 Hz
Nominal impedance	1.8 k $\Omega$
Sensitivity	6.3 mV/Pa
Max. sound pressure	130 dB
Power supply	pocket transmitter IN/PT/UF series or PS-500
Weight	20 g
Connection	4-pole mini XLR (optional: 3.5 mm stereo plug, 3-pole mini XLR or 4-pole Hirose connector)



## CM-801F

Order No. 0235900

### Electret earband microphone

- Ultra-light earband microphone for stage and podium
- Optimum speech intelligibility
- Movable drip ring
- Screwed-on cable, easy to replace
- Clip for strain relief; makes microphone more comfortable to wear and enhances stable positioning
- Other connection cables are available at option
- Supplied with bag and windshield

Model	CM-801F
Polar pattern	omnidir.
System	electret
Audio frequency range	60-15,000 Hz
Nominal impedance	1.8 kΩ
Sensitivity	6.3 mV/Pa
Max. sound pressure	130 dB
Power supply	pocket transmitters of the IN/PT/UF series or PS-500
Weight	16 g
Connection	4-pole mini XLR (optional: 3.5 mm stereo plug, 3-pole mini XLR or 4-pole Hirose connector)



## CM-214U

Order No. 0236440

### Electret headband microphone

- For stage, presentations and general speech applications
- Cardioid polar pattern and a vibration-reducing cartridge support allow for maximum protection against acoustic feedback and ensure minimum structure-borne noise
- Adjustable headband
- Secure fit, very comfortable to wear
- Supplied with a 4-pole mini XLR connection cable for connection to pocket transmitters of the IN/PT/UF series
- Supplied with bag and windshield

Model	CM-214U
Polar pattern	cardioid
System	electret
Audio frequency range	30-18,000 Hz
Nominal impedance	680 Ω
Sensitivity	4 mV/Pa
Max. sound pressure	130 dB
Power supply	pocket transmitter of the IN/PT/UF series or PS-500
Weight	40 g
Connection	4-pole mini XLR



## HSE-340/SK

Order No. 1000026



**Professional headband microphone**, with cardioid polar pattern and a high-quality sound which is suitable for any vocal or speech application. Innovative design features ensure a maximum suppression of both the impact sound and structure-borne noise as well as an extra low acoustic feedback, very comfortable to wear. Beige version.

- Corrosion-resistant neckband, easy to clean
- Drip ring (protects cartridge from moisture)
- Unobtrusive and secure fit due to cable routing in neck area incl. strain relief and cable bending protection
- Stable positioning

Model	HSE-340/SK
Polar pattern	cardioid
System	electret
Audio frequency range	50-18,000 Hz
Nominal impedance	2 kΩ
Sensitivity	2.3 mV/Pa
Max. sound pressure	120 dB
Power supply	1.5-9 V
Weight	18 g (w/o cable and plug)
Connection	4-pole mini XLR

- Microphone windshield
- 4-pole mini XLR inline jack for connection to pocket transmitters from JTS or a pocket transmitters of the same design from other brand manufacturers

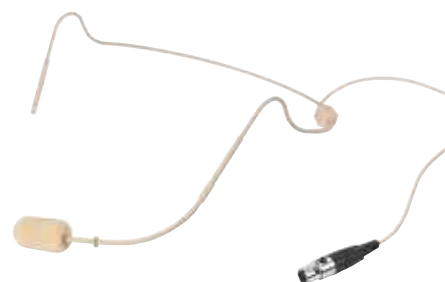

## NM-43

Order No. 0235070

### Neckband

- Matching the lavalier microphone CM-501
- Adjustable
- Lightweight plastic version

Supplied w/o microphone.



## PT-RMS

Order No. 0236870

### External mute button (cough button)

- For tie clip microphones and headband microphones from JTS
- Selectable switching mode (ON/OFF, momentary ON, momentary OFF)
- 4-pole mini XLR connection
- Compatible with any pocket transmitter from JTS



# Headband Microphones and Lavalier Microphones

## CM-501

Order No. 0234690

### Electret lavalier microphone

- For presentations and discussions
- Good audibility, secure fit due to supplied tie clip, easy to attach
- Cardioid polar pattern
- Allows to pick up a precise voice of high quality over a wide dynamic range
- Supplied with windshield

Model	CM-501
Polar pattern	cardioid
System	electret
Audio frequency range	100-15,000 Hz
Nominal impedance	2.2 k $\Omega$
Sensitivity	3.2 mV/Pa
Max. sound pressure	130 dB
Power supply	pocket transmitter IN/PT/UF series or PS-500
Weight	20 g
Connection	4-pole mini XLR



## CM-125IB

Order No. 0235940

## CM-125IF

Order No. 0235950

### Electret lavalier microphones, miniature version.

- High-quality microphone cartridge with omnidirectional polar pattern
- Excellent sound characteristics
- Removable clip and 1.4 m connection cable
- 4-pole mini XLR inline jack for connection to a pocket transmitter of the IN/PT/UF series
- Beige (CM-125IF) or black (CM-125IB) version
- Supplied with bag and windshield

Model	CM-125IB	CM-125IF
Polar pattern	omnidir.	omnidir.
System	electret	electret
Audio frequency range	50-18,000 Hz	50-18,000 Hz
Nominal impedance	4.4 k $\Omega$	4.4 k $\Omega$
Sensitivity	2.2 mV/Pa	22 mV/Pa
Max. sound pressure	130 dB	130 dB
Power supply	pocket transmitter of the IN/PT/UF series or PS-500	pocket transmitter of the IN/PT/UF series or PS-500
Weight	15 g	15 g
Connection	4-pole mini XLR	4-pole mini XLR



## 801CR

Order No. 0236530

## 801CR/B

Order No. 0237250

### Connection cable

- Beige (801CR) or black (801CR/B) version
- 4-pole Hirose connector
- Length: 150 cm
- Suitable for CM-801F, CM-804IF, CM-214F, CM-214ULF and CM-235IF, CM-235IB



## 801CS

Order No. 0236110

## 801CS/B

Order No. 0237260

### Connection cable

- Beige (801CS) or black (801CS/B) version
- Screwable 3.5 mm plug
- Length: 150 cm
- Suitable for CM-801F, CM-804IF, CM-214F, CM-214ULF and CM-235IF



## 801C3

Order No. 0236120

## 801C3/B

Order No. 0237240

### Connection cable

- Beige (801C3) or black (801C3/B) version
- 3-pole mini XLR connector
- Length: 150 cm
- Suitable for CM-801F, CM-804IF, CM-214F, CM-214ULF and CM-235IF, CM-235IB



## 801C4

Order No. 0069240

## 801C4/B

Order No. 0069410

### Connection cable

- Beige (801C4) or black (801C4/B) version
- 4-pole mini XLR connector
- Length: 150 cm
- Suitable for CM-801F, CM-804IF, CM-214F, CM-214ULF and CM-235IF, CM-235IB





## CX-500F

Order No. 0236190

**Miniature electret instrument microphone**, for sound pickup of flutes.

- Gold-plated back electret cartridge with omnidirectional polar pattern
- Very precise frequency response
- Innovative, glueless fastening system (for tube diameter: 18-26 mm)
- Flexible miniature gooseneck for exact positioning of the microphone
- 4-pole mini XLR inline jack for connection to a pocket transmitter of the IN/PT/UF series, other connection cables are available at option
- Supplied with phantom power supply adapter MA-500 for wired connection to a mixer

Model	CX-500F
Polar pattern	omnidir.
System	back electret
Audio frequency range	20-20,000 Hz
Nominal impedance	1.5 k $\Omega$
Sensitivity	12,6 mV/Pa
Max. sound pressure	130 dB
Power supply	= 48 V, phantom power via power supply adapter
Housing material	plastic
Weight	8 g
Cable	1,4 m
Connection	4-pole mini XLR adapter: XLR, bal.

- Supplied with robust transport case, phantom power supply adapter and windshield



## CX-500DUSET

Order No. 0236710

**Miniature electret instrument microphone**

- For acoustic guitars, string instruments and other acoustic instruments
- Combined with the integrated contact microphone, it creates a genuine sound which is rich in detail and perfectly delivers the natural sound characteristics of the instrument across a wide dynamic range
- Individual volume control of instrument microphone and contact microphone possible via supplied phantom power supply adapter/mixer
- Supplied with 2 windshields, 2 self-adhesive pads

Model	CX-500DUSET
Polar pattern	omnidir.
System	back electret
Audio frequency range	20-20,000 Hz
Nominal impedance	1.5 k $\Omega$
Sensitivity	12,6 mV/Pa
S/N ratio	68 dB
Max. sound pressure	130 dB
Power supply	= 1-5 V via PS-510M
Weight	6,5 g
Connection	2 x 4-pole mini XLR

- Supplied in a robust plastic case



## CX-500

Order No. 0235850

**Miniature electret instrument microphone**

- For strings and other acoustic instrumentalists
- Pure and powerful sound which perfectly reproduces the natural sound characteristics of the instrument across a wide dynamic range
- Versatile options for attaching the microphone and precisely position it to achieve a perfect alignment and protect the instrument from damage
- 10 dB attenuator and 2 switchable low cut filters in the phantom power supply adapter
- Power supply adapter with belt clip

Model	CX-500
Polar pattern	omnidir.
System	electret
Nominal impedance	1.5 k $\Omega$
Sensitivity	6,3 mV/Pa
Max. sound pressure	130 dB
Power supply	= 48 V, phantom power via MA-500
Housing material	plastic
Weight	15 g
Connection	4-pole mini XLR adapter: XLR, bal.

- Wireless operation possible with respective wireless systems from JTS
- Supplied with 48 V phantom power supply adapter, 2 tailpieces, 5 body clips, 4 windshields, 26 self-adhesive pads
- Supplied in a robust plastic case



## CX-500FHW

Order No. 0235980

**Electret headband microphone**, for sound pickup of flutes.

- High-quality microphone cartridge with omnidirectional polar pattern
- Very comfortable to wear
- Adjustable headband
- Microphone boom adjustable in length
- Suitable for kids
- Drip ring (protects cartridge from moisture)
- 4-pole mini XLR inline jack for connection to pocket transmitter of the IN/PT/UF series, other connection cables are available at option

Model	CX-500FHW
Polar pattern	omnidir.
System	electret
Audio frequency range	20-20,000 Hz
Nominal impedance	1.5 k $\Omega$
Sensitivity	12,5 mV/Pa
Max. sound pressure	130 dB
Power supply	pocket transmitter IN/PT/UF series or = 12-48 V, phantom power via MA-500
Weight	6,5 g
Connection	4-pole mini XLR

- Supplied with phantom power supply adapter MA-500 for wired connection to a mixer
- Supplied with bag, clip and windshield



# Instrument Microphones

## CX-520

Order No. 0236200

### Dynamic instrument microphone

- For blues harp harmonica players and traditional harmonica players
- Vocalists of techno or dance music like to use it for adding a special effect to their performance
- Dynamic supercardioid cartridge for a constant quality over a wide dynamic range
- Robust diecast body of an ergonomic design
- Volume control directly at the microphone
- Wireless operation directly via any pocket transmitter from JTS

Model	CX-520
Polar pattern	supercardioid
System	dynamic
Audio frequency range	15-16,500 Hz
Nominal impedance	600 Ω
Sensitivity	1,3 mV/Pa
Max. sound pressure	148 dB
Weight	350 g
Cable	1,4 m
Connection	4-pole mini XLR adapter: XLR, bal.

- Wired operation possible via supplied adapter MA-500 (with additional features, e.g. switchable low cut filter and PAD) and optional XLR cable
- Supplied with robust transport case and cable adapter



## CX-516

Order No. 0234640

## CX-516W

Order No. 0234630

### Electret instrument microphones

- For sound pickup of accordions, pianos or wind instruments
- Well-balanced frequency response for a genuine and brilliant sound
- Structure-borne noise isolated cartridge
- Flexible gooseneck
- Quick-acting holder of special design
- Supplied in a robust transport case with windshield

Model	CX-516	CX-516W
Polar pattern	supercardioid	supercardioid
System	electret	electret
Audio frequency range	20-20,000 Hz	20-20,000 Hz
Nominal impedance	220 Ω ± 30%	220 Ω ± 30%
Sensitivity	5,6 mV/Pa	4,5 mV/Pa
Max. sound pressure	130 dB	130 dB
Power supply	48 V phantom power	pocket transmitter from JTS
Housing material	plastic	plastic
Weight	63 g	55 g
Cable	3,3 m	1,4 m
Connection	3-pole XLR	4-pole mini XLR



## CX-508

Order No. 0234610

## CX-508W

Order No. 0234620

### Electret instrument microphones

- For sound pickup of wind instruments
- Wide dynamic range
- Crystal-clear and crisp sound
- Integrated spring-type clamp to attach to a horn
- Robust gooseneck, can be turned by 230°
- Design of low structure-borne noise with low susceptibility to wind noise
- Supplied in a robust transport case and windshield

Model	CX-508	CX-508W
Polar pattern	cardioid	cardioid
System	electret	electret
Audio frequency range	50-18,000 Hz	50-18,000 Hz
Nominal impedance	220 Ω	220 Ω
Sensitivity	5 mV/Pa	4,5 mV/Pa
Max. sound pressure	130 dB	130 dB
Power supply	48 V phantom power	pocket transmitter from JTS
Housing material	plastic	plastic
Weight	170 g	170 g
Cable	3,3 m	1,4 m
Connection	3-pole XLR	4-pole mini XLR



## CX-505

Order No. 0234590

### Electret instrument microphone

- State-of-the-art microphone for drummers and percussionists
- Brilliant sound which is always accentuated and powerful, even at great dynamic gaps
- Clamp with rubber jaws, to be attached to the rim of drums
- Miniature gooseneck, can be turned by 230°
- Suppression of structure-borne noise
- Supplied in a robust transport case

Model	CX-505
Polar pattern	cardioid
System	electret
Audio frequency range	50-18,000 Hz
Nominal impedance	220 Ω
Sensitivity	5,6 mV/Pa
Max. sound pressure	130 dB
Power supply	≙ 48 V, phantom power
Housing material	plastic
Weight	187 g
Connection	XLR, bal.



**NX-9**

Order No. 0234750

**Overhead electret microphone**

- For various applications: sound pickup of hi-hats/ cymbals/percussion instruments, microphone applications with acoustic instruments, e.g. guitars, violins, pianos or wind instruments
- Well-balanced and natural sound
- Operation via +48 V phantom power or via 1.5 V battery AA size (not supplied)
- Supplied with microphone holder and padded bag

Model	NX-9
Polar pattern	cardioid
System	electret
Audio frequency range	60-18,000 Hz
Nominal impedance	400 $\Omega$ $\pm$ 30%
Sensitivity	3,2 mV/Pa
Max. sound pressure	145 dB
Power supply	= 48 V phantom power or 1 x batt. AA size (not supplied)
Housing material	diecast metal
Weight	230 g
Connection	XLR, bal.

**NX-2**

Order No. 0234820

**Dynamic instrument microphone**

- For sound pickup of bass drums, kick drums, bass amplifiers or various other bass instruments
- Suppression of structure-borne noise/impact noise
- Excellent mechanical features
- Integrated stand holder
- Supplied with padded bag

Model	NX-2
Polar pattern	supercardioid
System	dynamic
Audio frequency range	20-12,000 Hz
Nominal impedance	600 $\Omega$
Sensitivity	0,6 mV/Pa
Max. sound pressure	172 dB
Housing material	diecast metal
Weight	800 g
Connection	XLR, bal.

**NX-6**

Order No. 0234810

**Dynamic instrument microphone**

- For sound pickup of drums or percussion instruments, e.g. snare drums, tom-toms, congas or bongos
- Also suitable for use as a microphone with wind instruments, at a guitar amplifier or for sound pickup of acoustic instruments
- Transparent and very powerful sound
- Suppression of structure-borne noise
- High-quality workmanship of the mechanical features
- Integrated stand holder with continuously variable adjustment
- Supplied with padded bag

Model	NX-6
Polar pattern	cardioid
System	dynamic
Audio frequency range	60-16,000 Hz
Nominal impedance	600 $\Omega$
Sensitivity	2,5 mV/Pa
Max. sound pressure	158 dB
Housing material	diecast metal
Weight	610 g
Connection	XLR, bal.



# Vocal Microphones and Studio Microphones

## NX-8.8

Order No. 0234760

### Electret vocal microphone

- Excellent vocal sound which allows studio quality at live performances
- High-quality electret condenser cartridge for a warm and natural sound with a high resistance to acoustic feedback
- Filter technology minimises breathing noise and pop noise
- Robust diecast body and stable basket
- Supplied with microphone holder and padded bag

Model	NX-8.8
Polar pattern	supercardioid
System	electret
Audio frequency range	60-18,000 Hz
Nominal impedance	400 $\Omega$ $\pm$ 30%
Sensitivity	3.2 mV/Pa
Max. sound pressure	136 dB
Power supply	= 48 V phantom power
Housing material	diecast metal
Weight	290 g
Connection	XLR, bal.



## NX-8

Order No. 0234770

### Dynamic vocal microphone

- Accentuated and clear voice reproduction
- Wide dynamic range
- Significantly reduced transmission of the handling noise
- Non-slip and durable due to special stove-enamel finish
- High-quality and solid workmanship
- Supplied with microphone holder and padded bag

Model	NX-8
Polar pattern	cardioid
System	dynamic
Audio frequency range	50-16,500 Hz
Nominal impedance	600 $\Omega$
Sensitivity	2.5 mV/Pa
Max. sound pressure	138 dB
Housing material	diecast metal
Weight	245 g
Connection	XLR, bal.



## NX-8S

Order No. 0234780

### Dynamic vocal microphone

- Accentuated and clear voice reproduction
- Wide dynamic range
- Low-noise reed switch resistant to wear
- Significantly reduced transmission of the handling noise
- Non-slip and durable due to special stove-enamel finish
- High-quality and solid workmanship
- Supplied with microphone holder and padded bag

Model	NX-8S
Polar pattern	cardioid
System	dynamic
Audio frequency range	50-16,500 Hz
Nominal impedance	600 $\Omega$
Sensitivity	2.5 mV/Pa
Max. sound pressure	138 dB
Housing material	diecast metal
Weight	245 g
Connection	XLR, bal.



## TK-600

Order No. 0234890

### Dynamic vocal microphone

- Impressive vocal microphone, also meets high requirements, available at an attractive price
- Powerful and brilliant sound reproduction
- Minimised handling noise
- Low susceptibility to acoustic feedback
- Mechanical stability
- Low-noise reed switch resistant to wear
- Supplied with connection cable

Model	TK-600
Polar pattern	cardioid
System	dynamic
Audio frequency range	50-16,000 Hz
Nominal impedance	600 Ω
Sensitivity	1.8 mV/Pa
Max. sound pressure	147 dB
Housing material	diecast metal
Weight	380 g
Cable	XLR, bal.
Connection	XLR, bal.



## TK-350

Order No. 0234880

### Dynamic vocal microphone

- Frequency response optimised for vocals
- Clear voice reproduction
- Powerful band sound
- Minimised handling noise and structure-borne noise, low susceptibility to acoustic feedback
- High-quality reed switch allows silent switching actions
- Supplied with connection cable

Model	TK-350
Polar pattern	cardioid
System	dynamic
Audio frequency range	80-12,000 Hz
Nominal impedance	600 Ω
Sensitivity	1.8 mV/Pa
Max. sound pressure	145 dB
Housing material	diecast metal
Weight	380 g
Cable	XLR, bal., XLR, bal.
Connection	XLR, bal.



## TM-929

Order No. 0234940

### Dynamic vocal microphone

- High-quality entry-level microphone, classic design
- Robust body
- Suppression of handling noise and acoustic feedback
- Low-noise reed switch
- Supplied with connection cable

Model	TM-929
Polar pattern	cardioid
System	dynamic
Audio frequency range	50-15,000 Hz
Nominal impedance	600 Ω
Sensitivity	1.8 mV/Pa
Max. sound pressure	148 dB
Housing material	diecast metal
Weight	350 g
Cable	XLR, bal., 6.3 mm plug, unbal.
Connection	XLR, bal.



# Vocal Microphones and Studio Microphones/Portable Amplifier System

## PDM-3

Order No. 0234850

### Dynamic vocal microphone

- Frequency response especially optimised for the vocal spectrum
- Low handling noise and high acoustic feedback suppression
- Robust design for a long life
- Supplied with connection cable

Model	PDM-3
Polar pattern	cardioid
System	dynamic
Audio frequency range	50-16,500 Hz
Nominal impedance	600 Ω
Sensitivity	1.8 mV/Pa
Max. sound pressure	147 dB
Housing material	diecast metal
Weight	315 g
Cable	XLR, bal., XLR, bal.
Connection	XLR, bal.



## PDM-57

Order No. 0234860

### Universal dynamic microphone

- For general sound pickup of instruments and for live performances
- Natural sound characteristics
- Characteristic sound with a high recognition value
- Supplied with connection cable

Model	PDM-57
Polar pattern	cardioid
System	dynamic
Audio frequency range	50-16,500 Hz
Nominal impedance	600 Ω
Sensitivity	1.8 mV/Pa
Max. sound pressure	145 dB
Housing material	diecast metal
Weight	250 g
Cable	XLR, bal., XLR, bal.
Connection	XLR, bal.



## CP-40

Order No. 0235250

**Replacement microphone head**, suitable for PDM-3 as well as microphones of the same design from other brand manufacturers.





**WA-35**

Order No. 0172940

**Portable MP3 FM amplifier system with wireless microphone**

- Compact and ultra-light class D amplifier system (total weight: 1.75 kg)
- Power capability of 25 W in battery operation (integrated 14.8 V rech. LiPo battery) and 35 W with power supply
- Ideally suited for outdoor applications due to splash-proof housing, stainless steel screws, impregnated full range speaker with dual cone and push-on silicone cover for the control unit
- MP3 reproduction via USB interface and SD card slot
- FM radio with 20 station presets
- Wireless 16-channel microphone system in the licence-free range 863-865 MHz (1 x 1.5 V battery, AA size, not supplied)
- Sound adjustment
- Connection facility for a cable-connected microphone
- Alarm siren: 2-tone and wailing sound

Model	WA-35
Rated power (P <sub>RMS</sub> )	25 W (rech. batt.), 35 W (mains)
Peak output power	60 W
Carrier frequency	863-865 MHz
Power supply	14.8 V rech. LiPo battery, via power supply
Dimensions	146 x 179 x 223 mm
Weight	1.75 kg
Connections	1 x 6.3 mm jack (mic), 1 x USB

- LED lamp with continuous light, automatic SOS light and automatic flashing light
- Charging status indication
- Deep discharge protection
- 9 mm (3/8") stand sleeve
- Integrated recessed carrying handle
- Robust carrying strap with integrated microphone bag

**Licence-free in the EU.****HP-565**

Order No. 0221300

**Professional studio headphones**

- Excellent sound quality and a rich bass reproduction
- Semi-open system, over-ear
- Padded ear cushions and headband, comfortable to wear
- 3 m cable with single-sided cable inlet
- 3.5 mm plug with 6.3 mm adapter

Model	HP-565
Headphone driver	neodymium, Ø 40 mm
Type of transducer	dynamic
Max. input power	500 mW
Transmission range, headphones	20-20,000 Hz
Nominal impedance, headphones	32 Ω
Headphone sensitivity	104 dB/mW
Cable	3 m, single-sided cable inlet
Plug	3.5 mm plug, gold-plated
Adapter	6.3 mm plug, gold-plated
Weight w/o cable	350 g

**HP-535**

Order No. 0220790

**Professional studio monitor headphones**

- Excellent sound quality, very comfortable to wear
- Semi-open system, over-ear
- Padded ear cushions and headrest
- 2 m cable with single-sided cable inlet
- 3.5 mm plug with 6.3 mm adapter

Model	HP-535
Headphone driver	neodymium, Ø 40 mm
Type of transducer	dynamic
Max. input power	1 W
Transmission range, headphones	20-20,000 Hz
Nominal impedance, headphones	64 Ω
Headphone sensitivity	104 dB/mW
Cable	2 m, single-sided cable inlet
Plug	3.5 mm plug, gold-plated
Adapter	6.3 mm plug, gold-plated
Weight w/o cable	380 g

**HPM-535**

Order No. 0220210

**Professional stereo headphones with electret boom microphone**

- Excellent sound characteristics, comfortable to wear
- Semi-open system, over-ear
- Compatible with sound cards
- Ideally suited for gaming
- Adjustable microphone boom
- Padded ear cushions and headband
- 2 m cable with single-sided cable inlet and 3.5 mm plugs

Model	HPM-535
Headphone driver	neodymium, Ø 40 mm
Type of transducer	dynamic
Max. input power	1,000 mW
Transmission range, headphones	20-20,000 Hz
Nominal impedance, headphones	64 Ω
Headphone sensitivity	104 dB/mW
Transmission range, mic.	100-15,000 Hz
Nominal impedance, microphone	680 Ω
Microphone system	electret
Microphone sensitivity	6.3 mV/Pa/1 kHz
Power supply	= 1.5-10 V
Cable	2 m, single-sided cable inlet
Plug	2 x 3.5 mm plug, gold-plated
Weight w/o cable	308 g



# Boundary Microphones

## CM-601

Order No. 0235010

### Electret boundary microphone

- For theatrical performances, discussions, conferences and in churches
- A direct alignment to the sound source is not essential due to the special characteristics of a boundary microphone
- Dual low cut filter (80 Hz/120 Hz)
- Configurable push-button (PTT, PTM or switching function)
- Standby LED
- Robust and shock-absorbing body
- Elastic cartridge suspension for preventing structure-borne noise and impact sound

Model	CM-601
Transmission method	cable
Polar pattern	semi-cardioid
System	electret
Audio frequency range	30-12,000 Hz
Nominal impedance	100 Ω
Sensitivity	2.2 mV/Pa
Max. sound pressure	125 dB
Power supply	= 15-48 V, phantom power
Housing material	diecast metal
Weight	0.269 kg
Connection	XLR, bal.



## CM-602USB

Order No. 0231870



### Electret boundary microphone, with USB port.

- On/off switch with power LED
- Elastic cartridge suspension for preventing impact sound and structure-borne noise
- With 1.8 m USB connection cable

Model	CM-602USB
Polar pattern	semi-cardioid
System	electret
Audio frequency range	30-12,000 Hz
Nominal impedance	100 Ω
Sensitivity	2.2 mV/Pa
Max. sound pressure	125 dB
Power supply	via USB interface
Housing material	plastic
Dimensions	72 x 23 x 110 mm
Weight	88 g
Cable	1.8 m
Connection	USB type B jack



**SGM-14**

Order No. 0236730

**Electret shotgun microphone**

- For outdoor recordings, e.g. film productions and video productions
- Low-cut switch (80 Hz)
- 10 dB attenuation, switchable
- Supplied with microphone holder and windshield

Model	SGM-14
Polar pattern	hypercardioid
System	electret/condenser
Audio frequency range	20-20,000 Hz
Nominal impedance	200 Ω
Sensitivity	25 mV/Pa
Max. sound pressure	125 dB
Power supply	9-48 V phantom power
Dimensions	Ø 22 mm x 357 mm
Weight	195 g
Connection	3-pole XLR

**JS-22**

Order No. 0231970

**Professional condenser microphone**, for studio applications and live performances. Ideally suited for direct or overhead sound pickup of acoustic instruments, percussions and vocals or 2 x JS-22 for high-quality stereo recordings.

- 1.25 cm (1/2") extra thin gold-plated diaphragm
- Low cut switch (80 Hz)
- 10 dB attenuation, switchable
- 48 V phantom power
- Robust brass body of high quality
- Supplied accessories: robust hard-sided case, microphone windshield and microphone holder

Model	JS-22
Polar pattern	cardioid
System	condenser
Audio frequency range	20-20,000 Hz
Nominal impedance	100 Ω
Sensitivity	15,8 mV/Pa
S/N ratio	78 dB
Max. sound pressure	140 dB
Power supply	≐ 48 V, phantom power
Housing material	brass
Dimensions	Ø 20 mm x 150 mm
Weight	130 g
Connection	XLR, bal.

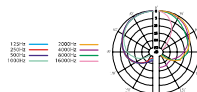
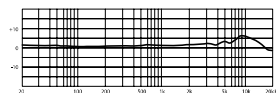
**CX-509**

Order No. 0234710

**Overhead electret microphone**

- For sound pickup of hi-hats/cymbals as well as various percussion instruments and acoustic instruments, e.g. guitars/violins, flutes or choir voices
- Excellent sound characteristics
- Unobtrusive positioning due to small dimensions
- Robust body with integrated phantom power supply adapter
- Supplied with microphone holder

Model	CX-509
Polar pattern	cardioid
System	electret/cardioid
Audio frequency range	20-20,000 Hz
Nominal impedance	220 Ω ± 30%
Sensitivity	5,6 mV/Pa
Max. sound pressure	130 dB
Power supply	48 V phantom power
Housing material	metal
Weight	60 g
Connection	XLR, bal.

**CM-502**

Order No. 0234580

**CM-502WT**

Order No. 0233990

**Overhead hanging electret microphones**

- For suspended installations, especially suitable for applications in which a direct microphonic effect is undesired for optical or operational reasons, e.g. sound pickup of choirs or on theatre stages or school stages
- Microphone cartridge with supercardioid polar pattern
- Integrated phantom power supply adapter
- Easy installation and alignment due to supplied mounting plate for ceiling suspension and spring holder
- Supplied with windshield

Model	CM-502	CM-502WT
Polar pattern	supercardioid	supercardioid
System	electret	electret
Audio frequency range	100-18,000 Hz	100-18,000 Hz
Nominal impedance	220 Ω	220 Ω
Sensitivity	4 mV/Pa	4 mV/Pa
Max. sound pressure	125 dB	125 dB
Power supply	≐ 12-48 V, phantom power	≐ 12-48 V, phantom power
Housing material	metal	metal
Weight	190 g	190 g
Cable	7.5 m	7.5 m
Connection	XLR, bal.	XLR, bal.

**CM-502WT: white version**

# Overhead Microphones

## CM-502G6B

Order No. 0233950

## CM-502G6W

Order No. 0233960

## CM-502G12B

Order No. 0233970

## CM-502G12W

Order No. 0233980

### Overhead hanging electret microphone

- For suspended installations, especially suitable for applications in which a direct microphonic effect is undesired for optical or operational reasons, e.g. sound pickup of choirs or on theatre stages or school stages
- Microphone cartridge with supercardioid polar pattern
- Integrated phantom power supply adapter
- Flexible alignment due to gooseneck
- Easy-to-replace cartridge unit
- Black (CM-502G...B) or white (CM-502G...W) version
- Supplied with windshield

### Total length:

CM-502G6...: 180 mm

CM-502G12...: 320 mm



CM-502G6B = black  
CM-502G6W = white

CM-502G12B = black  
CM-502G12W = white

Model	CM-502G6B, CM-502G6W	CM-502G12B, CM-502G12W
Polar pattern	supercardioid	supercardioid
System	electret	electret
Audio frequency range	100-18,000 Hz	100-18,000 Hz
Nominal impedance	220 Ω	220 Ω
Sensitivity	4 mV/Pa	4 mV/Pa
Max. sound pressure	125 dB	125 dB
Power supply	= 48 V, phantom power	= 48 V, phantom power
Housing material	metal	metal
Weight	100 g	145 g
Cable	8 m	8 m
Connection	XLR, bal.	XLR, bal.

## CM-22G6B

Order No. 0235990

## CM-22G6W

Order No. 0233920

## CM-22G12B

Order No. 0233930

## CM-22G12W

Order No. 0233940

### Overhead hanging condenser microphone

- For suspended installations, especially suitable for applications in which a direct microphonic effect is undesired for optical or operational reasons, e.g. sound pickup of choirs or on theatre stages or school stages
- High-quality condenser microphone cartridge with 1.25 cm (½") extra thin gold-plated diaphragm, cardioid polar pattern
- Low cut switch (80 Hz)
- 10 dB attenuation, switchable
- Integrated phantom power supply adapter
- Flexible alignment due to gooseneck
- Black (CM-22G...B) or white (CM-22G...W) version
- Supplied with windshield

### Total length:

CM-22G6...: 205 mm

CM-22G12...: 340 mm



CM-22G6B = black  
CM-22G6W = white

CM-22G12B = black  
CM-22G12W = white

Model	CM-22G6B, CM-22G6W	CM-22G12B, CM-22G12W
Polar pattern	cardioid	cardioid
System	condenser	condenser
Audio frequency range	20-20,000 Hz	20-20,000 Hz
Nominal impedance	100 Ω	100 Ω
Sensitivity	15.8 mV/Pa	15.8 mV/Pa
Max. sound pressure	140 dB	140 dB
Power supply	= 48 V, phantom power	= 48 V, phantom power
Housing material	metal	metal
Weight	140 g	160 g
Cable	8 m	8 m
Connection	XLR, bal.	XLR, bal.

## GM-5212

Order No. 0234380



## GM-5218

Order No. 0234390



### Electret gooseneck microphones

- Supercardioid polar pattern
- Excellent sound with a very high speech intelligibility
- Minimum susceptibility to acoustic feedback
- Solid and high-quality workmanship to ensure a long service life
- Gooseneck with integrated 3-pole XLR plug
- Operation via external phantom power or microphone base DMS-5

Model	GM-5212	GM-5218
Polar pattern	supercardioid	supercardioid
System	back electret	back electret
Audio frequency range	80-18,000 Hz	80-18,000 Hz
Nominal impedance	220 Ω ± 30%	220 Ω
Sensitivity	16 mV/Pa	16 mV/Pa
Max. sound pressure	125 dB	125 dB
Power supply	= 48 V phantom power	= 48 V phantom power
Dimensions	455 mm	605 mm
Weight	165 g	185 g
Connection	XLR, bal.	XLR, bal.

## GM-5212L

Order No. 0234410



## GM-5218L

Order No. 0234420



### Electret gooseneck microphones with LED

- Supercardioid polar pattern
- Natural sound
- Frequency response perfectly matched to the voice, precise voice reproduction
- Low susceptibility to acoustic feedback
- LED for indicating operating status
- Solid and high-quality workmanship to ensure a long service life

Model	GM-5212L	GM-5218L
Polar pattern	supercardioid	supercardioid
System	electret	electret
Audio frequency range	80-18,000 Hz	80-18,000 Hz
Nominal impedance	220 Ω ± 30%	220 Ω
Sensitivity	12.6 mV/Pa	12.6 mV/Pa
Max. sound pressure	125 dB	125 dB
Power supply	= 48 V phantom power	= 48 V phantom power
Dimensions	465 mm	615 mm
Weight	165 g	185 g
Connection	XLR, bal.	XLR, bal.

- Gooseneck with integrated 3-pole XLR plug
- Operation via external phantom power or desktop base DMS-5



## GML-5212

Order No. 0234560



## GML-5218

Order No. 0234570



### Electret gooseneck microphones with LED

- 3 replaceable microphone cartridges with different polar patterns (cardioid, supercardioid and omnidirectional)
- Excellent speech intelligibility
- -10 dB PAD switch
- Switchable low cut filter
- LED for indicating operating status
- Solid and high-quality workmanship to ensure a long service life

Model	GML-5212	GML-5218
Polar pattern	cardioid/supercardioid/omnidir.	cardioid/supercardioid/omnidir.
System	back electret	back electret
Audio frequency range	80-18,000 Hz	80-18,000 Hz
Nominal impedance	220 Ω ± 30%	220 Ω ± 30%
Sensitivity	16 mV/Pa	16 mV/Pa
Max. sound pressure	125 dB	125 dB
Power supply	= 48 V phantom power	= 48 V phantom power
Dimensions	465 mm	615 mm
Weight	230 g	245 g
Connection	XLR, bal.	XLR, bal.

- Gooseneck with integrated 3-pole XLR plug
- Operation via external phantom power or microphone base DMS-5



## GM-5212LDU

Order No. 0236290



## GM-5215LDU

Order No. 0236310



### Double gooseneck microphones with LED

- Back electret supercardioid cartridges
- High sensitivity
- 10 dB attenuator
- Low cut switch
- LED for indicating operating status
- Flexible positioning due to vertically adjustable goosenecks (160°)
- Common 3-pole XLR plug
- Operation via +48 V phantom power

Model	GM-5212LDU	GM-5215LDU
Polar pattern	supercardioid	supercardioid
System	back electret	back electret
Audio frequency range	80-18,000 Hz	80-18,000 Hz
Nominal impedance	220 Ω	220 Ω
Sensitivity	16 mV/Pa	16 mV/Pa
Max. sound pressure	125 dB	125 dB
Power supply	= 48 V phantom power	= 48 V phantom power
Dimensions	415 mm	492 mm
Weight	315 g	335 g
Connection	XLR, bal.	XLR, bal.



# Floor Stand Microphones and Built-in Microphones

## FGM-170T

Order No. 0231920



**Microphone floor stand**, with carbon fibre boom.

- High-quality condenser microphone cartridge with 1.25 cm (½") extra thin gold-plated diaphragm, cardioid polar pattern and excellent sound characteristics
- Low cut switch (80 Hz)
- 10 dB attenuation, switchable
- Extra lightweight (105 g) but very robust carbon fibre boom (1.46 m) with miniature gooseneck
- Long shaft, for overhead miking
- Structure-borne noise isolated diecast base plate
- Replaceable cartridge unit and cartridge (plug-in system with screw-type locking)

Model	FGM-170T
Polar pattern	cardioid
System	condenser
Audio frequency range	20-20,000 Hz
Nominal impedance	100 Ω
Sensitivity	15.8 mV/Pa
Max. sound pressure	140 dB
Power supply	≈ 48 V, phantom power
Dimensions	1.46 m (boom) 1.6 m (stand)
Weight	3.4 kg
Connection	3-pole XLR plug, bal.

- Supplied with windshield
- Delivery consists of 2 boxes



## FGM-170

Order No. 0236070



**Floor stand microphone**, with carbon fibre boom.

- 3 high-quality back electret microphone cartridges with different polar patterns
- Low cut switch (80 Hz)
- 10 dB attenuation, switchable
- Extra lightweight (105 g) but very robust carbon fibre boom (1.46 m) with miniature gooseneck
- Long shaft, for overhead miking
- Structure-borne noise isolated diecast base plate
- Supplied with 2 replacement cartridges, connection cable and windshield
- Delivery consists of 2 boxes

Model	FGM-170
Polar pattern	cardioid, supercardioid, omnidir.
System	back electret
Audio frequency range	50-18,000 Hz
Nominal impedance	220 Ω
Sensitivity	16 mV/Pa
Max. sound pressure	125 dB
Power supply	≈ 12-48 V, phantom power
Dimensions	1.46 m (boom) 1.6 m (stand)
Weight	3.6 kg
Connection	cable with 3-pole mini XLR to XLR



## CM-503U/B

Order No. 0231710

## CM-503U/W

Order No. 0231820

### Built-in electret microphones

- Microphone cartridge with semi-cardioid polar pattern
- Compact boundary microphone
- Low cut switch (80 Hz)
- 10 dB attenuation, switchable
- Metal housing
- Black (CM-503U/B) or white (CM-503U/W) cartridge cover

Model	CM-503U/B	CM-503U/W
Polar pattern	semi-cardioid	semi-cardioid
System	electret	electret
Audio frequency range	40-12,000 Hz	40-12,000 Hz
Nominal impedance	220 Ω	220 Ω
Sensitivity	4 mV/Pa	4 mV/Pa
S/N ratio	70 dB	70 dB
Max. sound pressure	140 dB	140 dB
Power supply	≈ 9-52 V, phantom power	≈ 9-52 V, phantom power
Housing material	metal	metal
Dimensions	31.6 x 69.7 x 30 mm	31.6 x 69.7 x 30 mm
Weight	67 g	67 g
Connection	XLR, bal.	XLR, bal.



## CM-503N/B

Order No. 0231720

## CM-503N/W

Order No. 0231730

### Built-in electret microphones

- Microphone cartridge with omnidirectional polar pattern
- Compact boundary microphone
- Low cut switch (80 Hz)
- 10 dB attenuation, switchable
- Metal housing
- Black (CM-503N/B) or white (CM-503N/W) cartridge cover

Model	CM-503N/B	CM-503N/W
Polar pattern	omnidir.	omnidir.
System	electret	electret
Audio frequency range	40-17,000 Hz	40-17,000 Hz
Nominal impedance	220 Ω	220 Ω
Sensitivity	4 mV/Pa	4 mV/Pa
S/N ratio	68 dB	68 dB
Max. sound pressure	140 dB	140 dB
Power supply	≈ 9-52 V, phantom power	≈ 9-52 V, phantom power
Housing material	metal	metal
Dimensions	31.6 x 69.7 x 30 mm	31.6 x 69.7 x 30 mm
Weight	67 g	67 g
Connection	XLR, bal.	XLR, bal.



## ST-5030

Order No. 0234360



### Desktop microphone base for gooseneck microphone

- Anti-slip coating at the bottom for a firm stand and for noise reduction
- High-quality on/off reed switch allows almost silent switching operation
- Selector switch at the bottom for choosing type of microphone used (electret/dynamic)
- Operation possible via +48 V phantom power or two 1.5 V batteries AA size (not supplied)

Model	ST-5030
Power supply	48 V phantom power or 2 x 1.5 V batt. AA size (not supplied) 0,88 mA (operation) 0,62 mA (standby)
Weight	1.1 kg
Connections	XLR, bal. (in/out)



## ST-5070

Order No. 0348240

### Shock-mount base with XLR socket

- Elastic rubber support for suppressing low-frequency structure-borne noise
- Solderless version with screw terminal
- Latching device to avoid accidental unplugging of gooseneck microphone

Model	ST-5070
Dimensions	82 x 43 x 86 mm
Weight	67 g
Connections	XLR jack, screw terminal



## ST-850

Order No. 0235510

### Gooseneck microphone for an optional wireless operation

- Matching pocket transmitters of the PT series
- High-quality back electret cartridge with supercardioid polar pattern
- Low-noise reed switch for on/off
- LED status indicator
- Solid diecast housing
- Optional pocket transmitter can be attached to the diecast base

Model	ST-850
Polar pattern	supercardioid
System	back electret
Audio frequency range	50-18,000 Hz
Nominal impedance	2 kΩ/100 Ω
Sensitivity	5 mV/Pa, 15.8 mV/Pa
Max. sound pressure	125 dB
Power supply	via pocket transmitter, +48 V phantom power
Gooseneck length	305 mm
Dimensions	110 x 65 x 150 mm
Weight	693 g
Connection	4-pole mini XLR inline jack, XLR panel plug



## ST-5000T

Order No. 0236890



### Gooseneck desktop microphone

- 1.25 cm (1/2") high-quality gold-plated condenser cartridge
- Low cut switch (80 Hz)
- 10 dB attenuation, switchable
- Low-noise ON/OFF button
- Power LED
- XLR output

Model	ST-5000T
Polar pattern	cardioid
System	condenser
Audio frequency range	20-20,000 Hz
Nominal impedance	100 Ω
Sensitivity	15,8 mV/Pa
S/N ratio	78 dB
Max. sound pressure	140 dB
Power supply	= 36-52 V, phantom power
Gooseneck length	122 mm
Dimensions	96 x 46 x 113 mm
Weight	748 g
Connection	XLR, bal.



## ST-5000

Order No. 0231900



### Gooseneck desktop microphone

- Back electret, supercardioid polar pattern
- Special RF shielding to avoid audible interference from smartphones
- ON/OFF switch
- Power LED
- Heavy-duty version
- Supplied with windshield

Model	ST-5000
Polar pattern	supercardioid
System	back electret
Audio frequency range	80-18,000 Hz
Nominal impedance	220 Ω
Sensitivity	10 mV/Pa
Max. sound pressure	125 dB
Power supply	= 12-48 V, phantom power
Gooseneck length	368 mm
Dimensions	96 x 46 x 113 mm (console housing)
Weight	820 g
Connection	XLR, bal.



## Accessories for Microphones

### MA-123

Order No. 0235490

#### Adjustable attenuator for balanced microphones

- For matching the microphone signal to mixers or preamplifiers
- Attenuation: 10 dB, 20 dB, 30 dB
- Also suitable for microphones with phantom power
- Metal body

Model	MA-123
Frequency range	22-20,000 Hz
Input impedance	1.6 k $\Omega$ -10 dB
Output impedance	660 $\Omega$ -10 dB
Dimensions	Ø 21 mm x 113 mm
Weight	46 g
Inputs	3-pole XLR jack
Outputs	3-pole XLR plug



### MA-SW

Order No. 0236520

#### In-line microphone switch

- For dynamic microphones and condenser microphones
- Bi-directional use
- Metal body

Model	MA-SW
Dimensions	Ø 21 mm x 113 mm
Weight	44 g
Connections	3-pole XLR jack, 3-pole XLR plug



### MA-PRS

Order No. 0236510

#### In-line phase reverser

- For balanced signals
- Bypass for phantom power
- Bi-directional use
- Metal body

Model	MA-PRS
Dimensions	Ø 21 mm x 113 mm
Weight	44 g
Connections	3-pole XLR jack, 3-pole XLR plug



### MA-HPF

Order No. 0236500

#### In-line high-pass filter

- For reducing low-frequency microphone signals
- Also suitable for microphones with phantom power
- Metal body

Model	MA-HPF
Output impedance	150 $\Omega$
Low cut	100 Hz (12 dB/oct.)
Dimensions	Ø 21 mm x 113 mm
Weight	50 g
Inputs	3-pole XLR jack
Outputs	3-pole XLR plug



## PS-510M

Order No. 0236720

### Phantom power supply adapter/mixer, battery-operated

- For supplying power to two microphones with 4-pole mini XLR plug (e.g. CX...W series, headband microphones and lavalier microphones of the CX/CM series)
- Allows operation at mixers, home recorders or similar devices without integrated +48 V phantom power
- Separate volume controls for the two microphones
- Adjustable headphone output
- Mute switch
- Belt clip

Model	PS-510M
Input voltage	9 V battery (not supplied) or 12-48 V phantom power
Connections	2 x 4-pole mini XLR (input) 1 x XLR, bal. (output) 1 x 3,5 mm jack (headphones)
Dimensions	65 x 92 x 30 mm
Weight	80 g

## MA-500

Order No. 0235890

### Phantom power supply adapter

- For electret microphones of the CM and CX series with 4-pole mini XLR connection
- 10 dB attenuator
- 2 switchable low cut filters
- Metal body with belt clip

Model	MA-500
Input voltage	= 12-48 V
Output voltage	= 12-48 V
Connections	4-pole mini XLR (microphone), 3-pole XLR (mixer)
Dimensions	Ø 20 mm x 96 mm
Weight	41 g



## MH-56

Order No. 0234730

### Microphone holder for wireless microphones

- Suitable for wireless microphones
- Rubber surround protects microphone from scratches and allows for a secure fit
- For tripod sockets: 9 mm (3/8") or 16 mm (5/8")



## MH-36

Order No. 0234720

### Microphone holder for standard microphones

- Suitable for microphones NX-7, NX-8
- Special composition of plastic materials guarantees high flexibility at an optimum form stability
- For tripod sockets: 9 mm (3/8") or 16 mm (5/8")



## MH-16

Order No. 0234740

### Microphone holder for slimline microphones

- Suitable for microphones NX-8,8 and NX-9
- For tripod sockets: 9 mm (3/8") or 16 mm (5/8")



## MH-22

Order No. 0236860

### Microphone holder

- Suitable for microphones JS-22, NX-9, CX-509 or similar models
- Good structure-borne noise isolation due to soft suspension
- For tripod sockets: 16 mm (5/8")



## CLP-6

Order No. 0235060

### Microphone holder

- Robust clamp allows for a secure attachment of microphone NX-6 to the rim of e.g. toms or snare drums
- Precise and optimum positioning of the microphones
- Microphone to be screwed directly to clamp



## GC-80

Order No. 0067070

### Guitar/bass cable

- For connecting an electric guitar to pocket transmitters of the PT/IN/UF series
- 6.3 mm metal plug with cable bending protection and 4-pole mini XLR inline jack with self-latching device
- Length: 70 cm



## CS-W4C/5

Order No. 1000017



## CS-W4C/6

Order No. 1000124



### 4-channel diversity UHF PLL wideband receiver for conference system

- Bandwidth: 36 MHz
- 6 groups, each with up to 22 compatible preset channels
- 1,441 selectable individual frequencies
- Conference modes: override, priority and open mode
- RF output and mains voltage output for easily cascading up to 10 x CS-W4C/5 receiver without additional splitter
- REMOSET technology for receiver/transmitter synchronisation
- Removable antennas (BNC connection)
- Auto-scan function
- Pilot tone squelch and noise mute
- Backlit display for indicating the status, e.g. for group/channel, frequency, battery, antenna A/B
- LED for indicating RF level and AF level
- Link connections
- Trigger output
- 482 mm (19") rack installation, 1 RS



**There are restrictions or requirements within the EU!**

**Please read the notes regarding wireless systems in the section "IMPORTANT INFORMATION"!**

Model	CS-W4C/5	CS-W4C/6
Carrier frequency range	506-542 MHz	626-662 MHz
Audio frequency range	60-16,000 Hz	60-16,000 Hz
THD	< 0.6%	< 0.6%
Dynamic range	> 105 dBA	> 105 dBA
Audio signal receiver	630 mV/600 Ω XLR (line), 63 mV/600 Ω XLR (mic), 316 mV/600 Ω jack	630 mV/600 Ω XLR (line), 63 mV/600 Ω XLR (mic), 316 mV/600 Ω jack
Power supply receiver	~ 110-240 V/50-60 Hz/20 VA	~ 110-240 V/50-60 Hz/20 VA
Dimensions receiver	485 x 45 x 260 mm	485 x 45 x 260 mm
Weight receiver	2.4 kg	2.4 kg

## CS-W4T/5

Order No. 1000018



## CS-W4T/6

Order No. 1000122



### UHF PLL microphone desk stand transmitter for the chairperson

- Back-electret microphone cartridge, supercardioid polar pattern
- 400 mm gooseneck, removable
- REMOSET technology for receiver/transmitter synchronisation
- Adjustable sensitivity
- Switchable transmitting power
- Low cut function
- Automatic switch-off
- Lock function
- LCD for indicating group/channel, audio level and battery status



Model	CS-W4T/5	CS-W4T/6
Carrier frequency range	506-542 MHz	626-662 MHz
Transmitting power	10/50 mW	10/50 mW
Operating time	≈ 25 h	≈ 25 h
Audio frequency range	60-16,000 Hz	60-16,000 Hz
Power supply	2 x batt. AA size, alkaline (not supplied)	2 x batt. AA size, alkaline (not supplied)
Gooseneck length	400 mm	400 mm
Dimensions	138 x 29 x 116 mm (console housing)	138 x 29 x 116 mm (console housing)
Weight	720 g	720 g

**There are restrictions or requirements within the EU!**

**Please read the notes regarding wireless systems in the section "IMPORTANT INFORMATION"!**

## JSS-4B/5

Order No. 0259390

### Dynamic hand-held UHF PLL transmitter

- Dynamic microphone cartridge (cardioid polar pattern) with wide dynamic range
- Aluminium housing
- Bandwidth: 36 MHz
- 6 groups, each with up to 22 compatible preset channels
- 1,441 selectable individual frequencies
- REMOSET technology for receiver/transmitter synchronisation
- Adjustable sensitivity (-15 dB to +15 dB)
- Lock/mute function
- 4-level display for indicating battery status and low battery alert, backlit LCD
- Switchable transmitting power

Model	JSS-4B/5
Transmission method	wireless
Polar pattern	cardioid
System	dynamic
Carrier frequency range	506-542 MHz
Transmitting power	10/50 mW
Power supply	2 x batt. AA size, alkaline (not supplied)
Operating time	> 20 h
Audio frequency range	50-18,000 Hz
Max. sound pressure	150 dB
Dimensions	Ø 50 mm x 253 mm
Weight	335 g

**There are restrictions or requirements within the EU!**

**Please read the notes regarding wireless systems in the section "IMPORTANT INFORMATION"!**



## W4-CH1

Order No. 1000019

**Charging station**, for a UHF PLL microphone desk stand transmitter CS-W4T/5.

- Average charging time, depending on condition of rechargeable batteries used: approx. 3 hours
- LED for indicating battery charging status
- Mechanical reverse polarity protection

- Protection against overload, short-circuit and deep discharge
- Supplied with 2 x NiMH rech. battery (2,000 mAh)

**Supplied w/o devices.**



## W4-CH12

Order No. 1000020

**Transport case with integrated charging function**, for UHF PLL microphone desk stand transmitter CS-W4T/5.

- For simultaneously charging rech. batteries of up to 12 devices
- Average charging time, depending on condition of rechargeable batteries used: approx. 5 hours
- Each slot with LED for indicating battery charging status
- Mechanical reverse polarity protection

- Protection against overload, short-circuit and deep discharge
- Supplied with 24 x NiMH rech. battery AA size (2,000 mAh)
- Butterfly locks and recessed drop handles
- Stackable
- Matching transport case cover W4-CH12/COVER is available at option and can be ordered separately

**Supplied w/o cover and devices.**



## W4-CH12/COVER

Order No. 1000021

**Transport case cover**

- Suitable for transport case with integrated charging function W4-CH12.



## Conference System CS-1

Your opinion will be heard! The control unit CS-1CU, the microphone station for the chairperson CS-1CH and the microphone station for conference delegates CS-1DU together form a conference system with extensive configuration facilities for maximum flexibility.



### CS-1CU

Order No. 0173060

#### Control unit, the control centre of the conference system

- For setting up a system with up to 50 microphone stations (2 x 25)
- Power supply for microphone stations
- Built-in speaker
- Headphone connection
- Keypad lock
- Display of date/time
- Stopwatch
- Test function for connected microphone stations
- Connection facilities for optional devices, e.g. external microphone, telephone coupler, signal processing units (e.g. equalizer), recorders, amplifiers, audio line sources

Model	CS-1CU
Power supply	100-240 V~/50-60 Hz/90 VA
Dimensions	360 x 90 x 150 mm
Weight	1.7 kg
Connections	2 x RCA (input/output for telephone coupler) 2 x RCA (input/output, e.g. for equalizer) 2 x RCA L/R (input/output for recorder) 2 x RCA (input/output for line signals) 1 x XLR (microphone input) 2 x 7-pole DIN jack (connection for microphone stations)

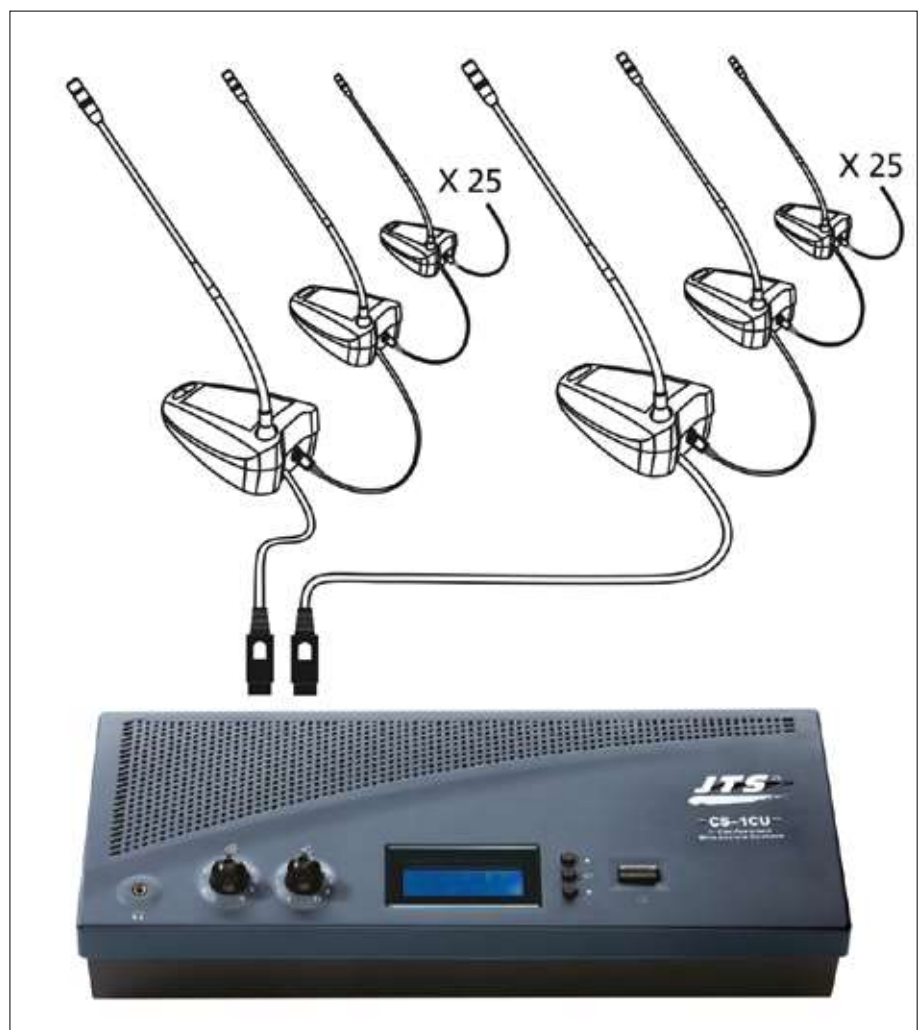



## CS-1CH

Order No. 0173070

### Microphone station for chairperson

- Back electret cartridge with cardioid polar pattern, optimised for voice transmissions
- Low-distortion speaker
- Reproduction via optional headphones
- Large function button
- Status displays at microphone and desktop station
- Priority button allows to interrupt an ongoing discussion between conference delegates, alternatively with a chime

Model	CS-1CH
Polar pattern	cardioid
System	back electret
Audio frequency range	50-18,000 Hz
Power supply	via control unit CS-1CU
Gooseneck length	400 mm
Dimensions	115 x 65 x 170 mm (console housing)
Weight	1.1 kg
Cable	2 m
Connection	2 x 3,5 mm jack 1 x 2 m connection cable with 7-pole DIN plug 1 x 7-pole DIN jack



## CS-1DU

Order No. 0173080

### Microphone station for conference delegates

- Back electret cartridge with cardioid polar pattern, optimised for voice transmissions
- Low-distortion speaker
- Operation via function button
- Headphone connection
- Status displays at microphone and desktop station

Model	CS-1DU
Polar pattern	cardioid
System	back electret
Audio frequency range	50-18,000 Hz
Power supply	via control unit CS-1CU
Gooseneck length	400 mm
Dimensions	115 x 65 x 170 mm (console housing)
Weight	1.1 kg
Cable	2 m
Connection	2 x 3,5 mm jack 1 x 2 m connection cable with 7-pole DIN plug 1 x 7-pole DIN jack



## D7P-10

Order No. 0173370

10 m

### Extension cable

- 7-pole DIN plug to 7-pole DIN jack
- Length: 10 m



## D7P-20

Order No. 0173380

20 m

### Extension cable

- 7-pole DIN plug to 7-pole DIN jack
- Length: 20 m



# Automatic Microphone Mixers

## The Automatic Microphone Mixers

of the CS series are THE perfect aid for concepts with multiple microphones, e.g. in conference rooms, churches or language laboratories. The main task of the mixer is to open the respective microphone channel when required and to close it again when the speaker has finished the presentation. This intelligent adjustment for the individual microphone channels allows for a silent and precise control which ensures that the audience hears every single word. This greatly improves the overall sound resulting in a clear, transparent reproduction and minimises acoustic feedback and irritating background noise. The CS mixers feature a last-in function in order to maintain a pleasant atmosphere with a soft ambient sound also during the breaks in conversation rather than just cutting off the sound.

### CS-8

Order No. 0173550

#### Automatic microphone mixer

- 8 channels
- 3 operating modes: auto mode, priority or 8/1-channel mixer
- Balanced XLR inputs, switchable mic/line
- Additional stereo RCA input
- 48 V phantom power
- Mix output, switchable mic/line
- Trigger outputs for external devices, e.g. warning devices, cameras or speakers
- Status LEDs
- Several devices can be combined via link connections (supplied with cable)
- Desktop metal housing
- 482 mm (19") rack installation possible with supplied mounting brackets

Model	CS-8
Mic input	0.2 mV/4.7 kΩ
Line input	60 mV/20 kΩ
Aux output	1 V/200 Ω
Frequency range	35-20,000 Hz
THD	< 0.06%
S/N ratio	> 70 dB
Power supply	via encl. plug-in power supply
Dimensions	420 x 44 x 199 mm
Weight	2.3 kg

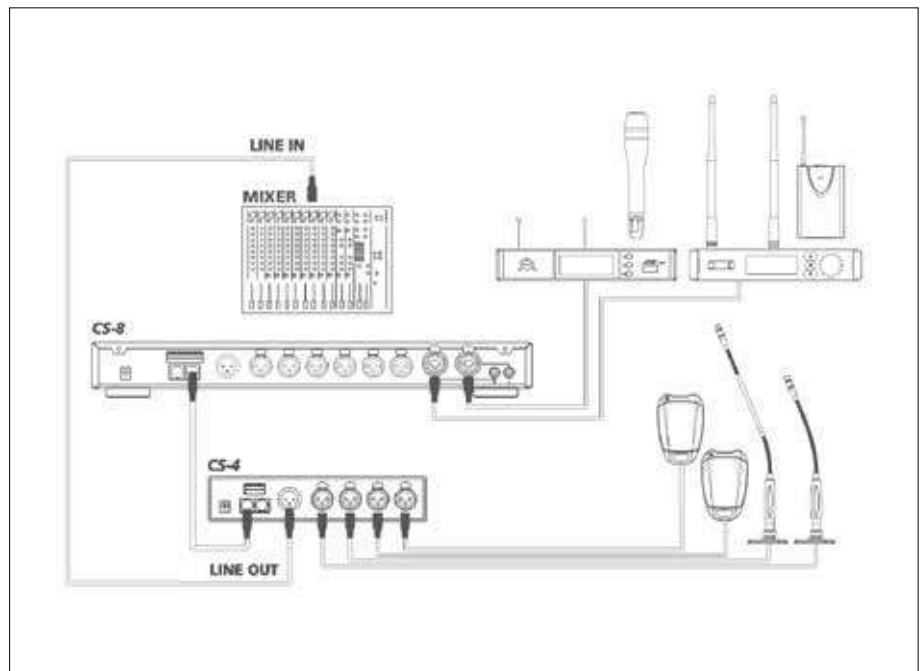
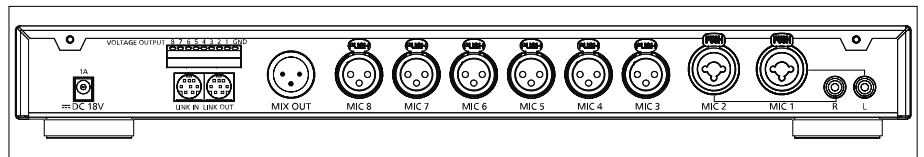

### CS-4

Order No. 0173540

#### Automatic microphone mixer

- 4 channels
- 3 operating modes: auto mode, priority or 4/1-channel mixer
- Balanced XLR inputs, switchable mic/line
- 12 V phantom power
- Mix output, switchable mic/line
- Trigger outputs for external devices, e.g. warning devices, cameras or speakers
- Status LEDs
- Several devices can be combined via link connections (supplied with cable)
- Desktop metal housing
- 482 mm (19") rack installation with supplied mounting brackets

Model	CS-4
Mic input	0.2 mV/4.7 kΩ
Line input	60 mV/20 kΩ
Aux output	1 V/200 Ω
Frequency range	35-20,000 Hz
THD	< 0.06%
S/N ratio	> 70 dB
Power supply	via encl. plug-in power supply
Dimensions	200 x 44 x 212 mm
Weight	1.4 kg

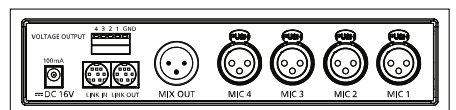

## IT-12M

Order No. 0173720

**Interpretation system, base unit**, for setting up a multilingual interpretation system.

- 12 languages (floor language/main language and 11 translations via interpretation console IT-12D)
- Slow-down signal
- Alarm function, audio message or audio alarm signal can be fed to each output
- Status LEDs for interpretation channels
- Microphone connection via comb. jack on the front panel
- 48 V phantom power supply
- 12 V power supply connections for wireless transmitters TG-10STX/1, available at option
- 482 mm (19") rack installation with supplied mounting brackets

Model	IT-12M
Description	interpretation system, base unit
Type	12 languages
Colour	black
Material	metal
Power supply	~ 230 V/50 Hz/90 VA
Dimensions	423 x 52 x 220 mm
Weight	2.6 kg
Connections	microphone connection (comb. jack), 12 V power supply connections for TG-10STX/1

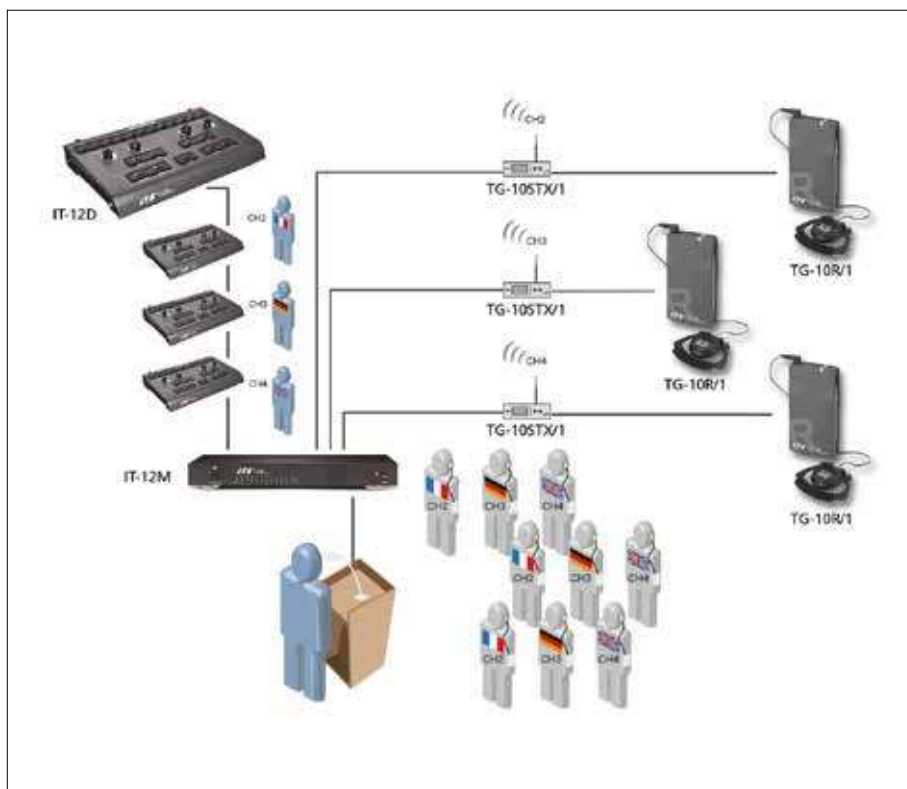

## IT-12D

Order No. 0173710

**Interpretation console**, as an addition to the base unit IT-12M.

- Up to 11 interpretation consoles can be cascaded
- 2 channels, one of which is active, the other serves as a standby channel
- Interpreting channels can be stored permanently at the console
- Last active channel will be stored after switching off the operating voltage and will be available again immediately after switching on the unit
- 2 simultaneous interpreters/commentators to use the active channel at the same time
- Headset connection with volume control
- Microphones can be switched off or muted, cough button
- Balanced XLR jacks for connecting additional microphones
- Relay interpreting via 11-step language selector
- Low-noise push-buttons for switching between relay language and floor language
- Protocol of interpretation via 2 record outputs
- Slow-down button
- Robust and stable metal housing
- Power supply via base unit



Model	IT-12D
Description	interpretation console
Type	2 channels
Colour	black
Material	metal
Suitable for	IT-12M
Power supply	via IT-12M
Dimensions	330 x 56 x 206 mm
Weight	2.3 kg
Connections	headset connection, bal. XLR jacks, record outputs

## Professional PLL Tour Guide System

- Bandwidth: 36 MHz
- 6 groups with up to 22 channels
- 124 channels
- 506-542 MHz
- Operating range: up to 200 m
- Operating time: approx. 10 hours
- There are restrictions or requirements within the EU!

### TG-98TA/5

Order No. 0257410

#### Professional PLL pocket transmitter

- Built-in electret microphone
- 3.5 mm microphone connection
- Supplied with matching electret tie clip microphone
- Audio input via 3.5 mm jack
- LCD for indicating channel/group, RF, mute and battery status
- Lock function
- Mute function
- Volume level control
- Selectable transmitting power
- Belt clip and lanyard
- Parallel operation possible of up to 22 transmitters max.

Model	TG-98TA/5
Carrier frequency range	506-542 MHz
Audio frequency range	40-18,000 Hz
Operating range	200 m
Power supply transmitter	2 x 1.2 V NiMH rech. batt. AA size (not supplied)
Dimensions transmitter	62 x 112 x 28 mm
Weight transmitter	72 g
Connections transmitter	1 x 3.5 mm jack (microphone), 1 x 3.5 mm jack (audio input)

**There are restrictions or requirements within the EU!**

**Please read the notes regarding wireless systems in the section "IMPORTANT INFORMATION"!**



### TG-98RA/5

Order No. 0257400

#### Professional PLL pocket receiver

- Built-in speaker
- 3.5 mm headphone connection
- Supplied with matching clip-on earphone with rubber ear hook
- Audio output via 3.5 mm jack
- LCD for indicating channel/group, RF and battery status
- Limiter function
- Automatic switch-off (power-saving function)
- Volume level control
- Belt clip and lanyard

**There are restrictions or requirements within the EU!**

**Please read the notes regarding wireless systems in the section "IMPORTANT INFORMATION"!**

Model	TG-98RA/5
Carrier frequency range	506-542 MHz
Audio frequency range	40-18,000 Hz
Operating time	10 h
Power supply receiver	2 x 1.2 V NiMH rech. batt. AA size (not supplied)
Dimensions receiver	62 x 112 x 28 mm
Weight receiver	72 g
Connections receiver	1 x 3.5 mm jack (headphones), 1 x 3.5 mm jack (audio output)



## 16-channel PLL Tour Guide System, 863-865 MHz

- With extensive accessories
- Operating range: up to 60 m
- Parallel operation of up to three wireless transmitters
- Licence-free in the EU

### TG-10R/1

Order No. 0253070

#### PLL pocket receiver

- 3.5 mm headphone connection
- Supplied with matching earphone with rubber ear hook
- Channel selector button
- LED channel indicator
- Volume level control
- Belt clip and lanyard

#### Licence-free in the EU.

Induction loop NL-90 for signal transmission to a hearing device available at option.

Model	TG-10R/1
Carrier frequency range	863-865 MHz
Audio frequency range	40-18,000 Hz
Operating time	12 h
Power supply receiver	rech. lithium-ion batt. 3.7 V/1,300 mAh
Dimensions receiver	54 x 99 x 17 mm
Weight receiver	80 g
Connections receiver	1 x 3.5 mm jack (headphones)



### TG-10T/1

Order No. 0253080

#### PLL pocket transmitter

- Built-in electret microphone
- 3.5 mm microphone connection
- Supplied with matching earband microphone CM-801F
- Channel selector button
- LED channel indicator
- Volume level control
- Belt clip and lanyard

#### Licence-free in the EU.

Model	TG-10T/1
Carrier frequency range	863-865 MHz
Audio frequency range	40-18,000 Hz
Operating range	60 m
Power supply transmitter	rech. lithium-ion batt. 3.7 V/1,300 mAh
Dimensions transmitter	54 x 99 x 17 mm
Weight transmitter	80 g
Connections transmitter	1 x 3.5 mm jack (microphone)



### TG-10STX/1

Order No. 0173730

#### 16-channel PLL wireless transmitter

- 2 inputs (CH1/CH2) via rear comb. jacks, with level controls
- 1 input (CH3) via 6.3 mm mono jack
- Continuously adjustable headphone output
- 2 loop outputs
- Phantom power can be activated as required

#### Licence-free in the EU.

Model	TG-10STX/1
Carrier frequency range	863-865 MHz
Audio frequency range	40-15,000 Hz
Operating range	60 m
Power supply transmitter	via encl. power supply
Dimensions transmitter	214 x 45 x 240 mm
Weight transmitter	1.3 kg
Connections transmitter	2 x comb. jack (input CH1/CH2), 1 x 6.3 mm mono jack (input CH3), 1 x 3.5 mm stereo jack (headphones), 2 x 6.3 mm mono jack (loop outputs)



# Tour Guide Systems

## KA-10/1PACK

Order No. 0253120

### Wireless 16-channel PLL audio transmission system for cameras

- Consisting of a portable audio transmitter and receiver
- Carrier frequency range: 863-865 MHz
- Transmitter and receiver with rechargeable lithium-ion batteries for reducing the weight and to ensure long operating times
- Transmitter can also be used for transmitting line signals (adjustment via recessed gain control)
- Receiver with 3-step PAD switch (0dB/-10 dB/-20 dB) for perfect level matching to the audio input of the camera
- Transmitter and receiver are fitted with a robust metal fixing clip
- Operating time: approx. 12 hours
- Supplied with lavalier microphone in skin design with windshield and tie clip, attachment clip for camera mounting, trim key, dual charging slot with plug-in switch-mode power supply, connection cable with 3,5 mm plug to 3,5 mm plug, connection cable with 3,5 mm plug to XLR plug

Model	KA-10/1PACK
Description	16-channel PLL audio transmission system
Carrier frequency range	863-865 MHz
Audio frequency range	40-18,000 Hz
THD	< 1%
Transmitting power	< 10 mW
Operating range	approx. 60 m
Power supply transmitter	3.7 V rech. lithium-ion battery
Dimensions transmitter	55 x 100 x 18 mm
Weight transmitter	80 g
Audio signal receiver	300 mV/7 kΩ (jack)
Power supply receiver	3.7 V rech. lithium-ion battery
Dimensions receiver	55 x 100 x 18 mm
Weight receiver	82 g
Connections receiver	1 x 3,5 mm jack (transmitter) 1 x 3,5 mm jack (receiver)

**Licence-free in the EU.  
Supplied w/o camera.**



## KA-8TH/1

Order No. 0254410

### Hand-held UHF PLL transmitter

- Matching the wireless 16-channel PLL audio transmission system for cameras KA-10/1PACK or the PLL pocket receiver TG-10R/1
- Condenser cartridge with cardioid polar pattern
- Adjustable sensitivity
- Mute function
- Battery status indication and LCD for indicating channel

Model	KA-8TH/1
Polar pattern	cardioid
System	condenser
Carrier frequency range	863-865 MHz
Transmitting power	10 mW
Power supply	2 x batt. AA size, alkaline (not supplied)
Operating time	approx. 20 h
Audio frequency range	40-16,500 Hz
Power supply	2 x 1,5 V batt. AA size
Dimensions	Ø 51 mm x 260 mm
Weight	216 g

**Licence-free in the EU.**



## BAG-ARM/S

Order No. 0236460

### Arm bag

- Suitable for components TG-10T/1 and TG-10R/1 of the tour guide system
- Ideally suited for mobile applications

- Flexible, adjustable strap
- Removable bag with hook and loop fastener



## BAG-BELT/S

Order No. 0236480

### Belt bag

- Suitable for components TG-10T/1 and TG-10R/1 of the tour guide system
- Ideally suited for mobile applications
- Flexible, adjustable strap
- Removable bag with hook and loop fastener





## TG-10CH2

Order No. 0252670

**Charging station** for transmitters TG-10T/1 and receivers TR-10R/1 as well as for KA-10 components.

- For simultaneously charging rech. batteries of 2 devices
- Average charging time, depending on condition of rechargeable batteries used: approx. 8 hours
- Each slot with LED for indicating battery charging status

Model	TG-10CH2
Suitable for	2 x TG-10T/1, TG-10R/1, KA-10 components
Power supply	via encl. power supply
Dimensions	75 x 41 x 85 mm
Weight	485 g



- Mechanical reverse polarity protection
- Protection against overload, short-circuit and deep discharge

**Supplied w/o devices.**

## TG-10CH18

Order No. 0252660

**Transport case with integrated charging function**, for transmitters TG-10T/1 and receivers TG-10R/1 as well as for KA-10 components.

- For simultaneously charging rech. batteries of up to 18 devices
- Average charging time, depending on condition of rechargeable batteries used: approx. 8 hours
- Each slot with LED for indicating battery charging status

Model	TG-10CH18
Suitable for	18 x TG-10T/1, TG-10R/1, KA-10 components
Power supply	via encl. switch-mode power supply
Dimensions	361 x 422 x 189 mm
Weight	3.26 kg

- Mechanical reverse polarity protection
- Protection against overload, short-circuit and deep discharge

**Supplied w/o devices.**

## TG-64CH18

Order No. 0259620

**Transport case with integrated charging function**, for transmitters and receivers of the TG-98 series as well as the TG-16 series.

- For simultaneously charging rech. batteries of up to 18 devices
- Average charging time, depending on condition of rechargeable batteries used: approx. 8 hours
- Each slot with LED for indicating battery charging status
- Mechanical reverse polarity protection

Model	TG-64CH18
Description	transport case with charging function
Colour	black
Suitable for	18 x TG-98RA/5, TG-98TA/5, TG-16RA/1, TG-16TA/1
Power supply	via encl. switch-mode power supply
Dimensions	362 x 422 x 189 mm
Weight	3.3 kg



- Protection against overload, short-circuit and deep discharge

**Supplied w/o devices.**

## TG-10CH36

Order No. 0252680

**Transport case with castors and integrated charging function**, for transmitters TG-10T/1 and receivers TG-10R/1 as well as for KA-10 components.

- For simultaneously charging rech. batteries of up to 36 devices
- Average charging time, depending on condition of rechargeable batteries used: approx. 8 hours
- Each slot with LED for indicating battery charging status
- Mechanical reverse polarity protection
- Protection against overload, short-circuit and deep discharge

Model	TG-10CH36
Suitable for	36 x TG-10T/1, TG-10R/1, KA-10 components
Power supply	via encl. switch-mode power supply
Dimensions	400 x 561 x 230 mm
Weight	7.3 kg



- Robust hard-sided plastic transport case with carrying handle
- Due to the integrated telescopic handle and 4 castors, the transport case can easily be pulled like a trolley
- Can be locked via key

**Supplied w/o devices.**



# Range of Applications for Microphones

Model	Page	Speech / Presentations	Vocals (solo)	Vocals (choir)	Drums / Percussion	Guitar amps	Bass amps	Acoust. Bass instruments	Wind instruments	Acoustic guitars	Bow instruments	Piano / Grand piano	Accordion	Harmonica	Film production / Features
CM-125IB	R148	•	•												
CM-125IF	R148	•	•												
CM-214F	R146	•	•												
CM-214U	R147	•	•												
CM-214ULF	R146	•	•												
CM-22G6B	R158			•											
CM-22G6W	R158			•											
CM-22G12B	R158			•											
CM-22G12W	R158			•											
CM-235IF	R146	•	•												
CM-501	R148	•													
CM-502	R157	•		•											
CM-502G6B	R158			•											
CM-502G6W	R158			•											
CM-502G12B	R158			•											
CM-502G12W	R158			•											
CM-502WT	R157	•		•											
CM-503N/B	R160	•													
CM-503N/W	R160	•													
CM-503U/B	R160	•													
CM-503U/W	R160	•													
CM-601	R156	•		•					•	•		•	•		
CM-602USB	R156	•		•					•	•		•	•		
CM-801F	R147	•	•												
CM-804IF	R146	•	•												
CX-500	R149								•	•	•				
CX-500F	R149								•						
CX-500DUSET	R149							•		•	•	•			
CX-500FHW	R149								•						
CX-505	R150				•										
CX-508	R150								•						
CX-508W	R150								•						
CX-509	R157			•	•					•	•				
CX-516	R150								•		•	•	•		
CX-516W	R150								•		•	•	•		
CX-520	R150													•	
FGM-170T	R160	•	•	•	•	•			•	•	•	•			
GM(L)	R159	•													
KA-8TH/1	R24, R172	•													•
KA-10/1PACK	R172	•													•
NX-2	R151				•		•	•	•						
NX-6	R151				•	•			•	•		•			
NX-8	R152	•	•	•											
NX-85	R152	•	•	•											
NX-8.8	R152	•	•	•											
NX-9	R152	•	•	•	•				•	•	•	•	•		
PDM-3	R154	•	•	•											
PDM-57	R154				•	•	•		•	•	•	•	•	•	
SGM-14	R157	•													•
ST-850	R161	•													
ST-5000	R161	•													
TK-350	R153	•	•	•											
TK-600	R153	•	•	•											
TM-929	R153	•	•	•											

- 8**  
801C3 ..... R148  
801C3/B ..... R148  
801C4 ..... R148  
801C4/B ..... R148  
801CR ..... R148  
801CR/B ..... R148  
801CS ..... R148  
801CS/B ..... R148  
850CH-2 ..... R136
- A**  
ANT-49 ..... R142  
ATR200 ..... R31  
ATS-10BAG ..... R28  
ATS-10PS ..... R22  
ATS-10R ..... R28  
ATS-10TM ..... R28  
ATS-12C ..... R29  
ATS-12CB ..... R26  
ATS-12HT ..... R28  
ATS-16BAG ..... R27  
ATS-16CORD ..... R27  
ATS-16PS ..... R27  
ATS-16R ..... R27  
ATS-16T ..... R27  
ATS-20R ..... R26  
ATS-20T ..... R26  
ATS-22R ..... R26  
ATS-22T ..... R26  
ATS-25C ..... R21  
ATS-30C ..... R29  
ATS-35CB ..... R26  
ATS-36C ..... R27  
ATS-42R ..... R22  
ATS-42T ..... R22  
ATS-50PS ..... R21  
ATS-50R ..... R21  
ATS-50T ..... R21  
ATS-60PS ..... R23  
ATS-60R ..... R23  
ATS-60T ..... R23  
ATS-62C ..... R23  
ATS-80EM ..... R19  
ATS-80R ..... R18  
ATS-80ST ..... R19  
ATS-80T ..... R18  
ATS-825C ..... R19  
ATS-850PS ..... R19  
ATS-85PS ..... R19  
ATT100 ..... R31
- B**  
BAG-ARM/S ..... R25, R172  
BAG-BELT/S ..... R25, R172  
BHS300N ..... R30
- C**  
C-RAY/8 ..... R96  
C-RAY/8BAG ..... R96  
C-RAY/8EXT ..... R96  
CD-196USB ..... R88  
CD-230USB ..... R88  
CD-292USB ..... R88  
CDMXN-1000/SW ..... R125  
CDMXN-150/SW ..... R125
- CDMXN-300/SW ..... R125  
CDMXN-500/SW ..... R125  
CH-2 ..... R133, R131  
CH-8 ..... R131  
CLP-6 ..... R163  
CM-125IB ..... R148  
CM-125IF ..... R148  
CM-214F ..... R146  
CM-214U ..... R147  
CM-214ULF ..... R146  
CM-22G12B ..... R158  
CM-22G12W ..... R158  
CM-22G6B ..... R158  
CM-22G6W ..... R158  
CM-235IF ..... R146  
CM-501 ..... R148  
CM-502 ..... R157  
CM-502G12B ..... R158  
CM-502G12W ..... R158  
CM-502G6B ..... R158  
CM-502G6W ..... R158  
CM-502WT ..... R157  
CM-503N/B ..... R160  
CM-503N/W ..... R160  
CM-503U/B ..... R160  
CM-503U/W ..... R160  
CM-601 ..... R156  
CM-602USB ..... R156  
CM-7 ..... R39  
CM-801F ..... R147  
CM-804IF ..... R146  
COHS ..... R30  
CP-40 ..... R154  
CS-1CH ..... R167  
CS-1CU ..... R166  
CS-1DU ..... R167  
CS-4 ..... R168  
CS-8 ..... R168  
CS-W4C/5 ..... R164  
CS-W4C/6 ..... R164  
CS-W4T/5 ..... R164  
CS-W4T/6 ..... R164  
CX-500 ..... R149  
CX-500DUSET ..... R149  
CX-500F ..... R149  
CX-500FHW ..... R149  
CX-505 ..... R150  
CX-508 ..... R150  
CX-508W ..... R150  
CX-509 ..... R157  
CX-516 ..... R150  
CX-516W ..... R150  
CX-520 ..... R150
- D**  
D7P-10 ..... R167  
D7P-20 ..... R167  
DELTA-160 ..... R33, R64  
DELTA-160R ..... R65, R33  
DEQ-230 ..... R87  
DIB-100 ..... R80  
DIB-102 ..... R80  
DJP-104USB ..... R89  
DJP-106SD ..... R89  
DJP-200USB ..... R89  
DM-065 ..... R40  
DM-101 ..... R40  
DM-1100 ..... R41  
DM-3 ..... R39  
DM-3S ..... R39  
DM-3SET ..... R41  
DM-5000LN ..... R40  
DM-7 ..... R39  
DM-9 ..... R38  
DM-9S ..... R38  
DMIX-20/2 ..... R66  
DMIX-20DTM/2 ..... R67  
DMIX-20IO/2 ..... R67  
DMIX-20WIFI ..... R67  
DMIX-20WIFI ..... R67  
DM-1218PAX ..... R126  
DN-4 ..... R126  
DR-900SET ..... R144  
DRUMSET-1 ..... R42  
DSM-26LAN ..... R86  
DSM-48LAN ..... R86  
DSP-26 ..... R86
- E**  
E-7BPSET/5 ..... R139  
E-7BPSETD/5 ..... R139  
E-7HHSET/5 ..... R138  
E-7HHSETD/5 ..... R138  
E-7TB/5 ..... R139  
E-7TH/5 ..... R138  
ECM-250 ..... R42  
ECM-270 ..... R43  
ECM-285 ..... R43  
ECM-3003 ..... R62  
ECM-300L ..... R62  
ECM-310W ..... R42  
ECM-40 ..... R43  
ECM-402L ..... R62  
ECM-500L/SK ..... R62  
ECM-501L/SK ..... R62  
ECM-821LT ..... R62  
ECMS-50USB ..... R37  
ECMS-60 ..... R36  
ECMS-70 ..... R36  
ECMS-90 ..... R36  
EMA-1 ..... R44  
EMA-200 ..... R44  
EMA-3 ..... R44  
EMA-300P ..... R44  
ES-16 ..... R22
- F**  
FGA-102 ..... R80  
FGA-202 ..... R80  
FGM-170 ..... R160  
FGM-170T ..... R160  
FLAT-M100 ..... R34, R104  
FLAT-M100BAG ..... R104  
FLAT-M200 ..... R104, R34  
FLAT-M200BAG ..... R104  
FLY-16R ..... R85, R35  
FLY-16SET ..... R35, R85  
FLY-16T ..... R85, R35
- G**  
G-5SET ..... R29  
G-7SET ..... R29  
G3CH-2 ..... R134  
GC-80 ..... R163  
GM-5212 ..... R159  
GM-5212L ..... R159  
GM-5212LDU ..... R159  
GM-5215LDU ..... R159  
GM-5218 ..... R159  
GM-5218L ..... R159  
GML-5212 ..... R159  
GML-5218 ..... R159  
GNL-300USB ..... R115  
GNL-450BNC ..... R115  
GNL-453XLR ..... R115  
GNL-454XLR ..... R115
- H**  
HP-535 ..... R155  
HP-565 ..... R155  
HPM-535 ..... R155  
HPR-6 ..... R83  
HS02T ..... R31  
HSE-110 ..... R61  
HSE-140/SK ..... R60  
HSE-150A/SK ..... R60  
HSE-152A/SK ..... R61  
HSE-200WP/BL ..... R60  
HSE-310/SK ..... R60  
HSE-340/SK ..... R147  
HSE-70A/SK ..... R61  
HSE-90 ..... R61
- I**  
IE-1 ..... R145  
IT-12D ..... R169  
IT-12M ..... R169
- J**  
JS-22 ..... R157  
JSS-20/5 ..... R130  
JSS-4B/5 ..... R165, R132
- K**  
KA-10/1PACK ..... R172  
KA-8TH/1 ..... R24, R172  
KATANA-M1 ..... R126  
KM-101 ..... R111  
KM-12190 ..... R114  
KM-12225 ..... R114  
KM-17515 ..... R114  
KM-17525 ..... R114  
KM-17650 ..... R114  
KM-18990 ..... R114  
KM-19740 ..... R115  
KM-19742 ..... R115  
KM-210/9 ..... R111  
KM-21302 ..... R113  
KM-21366 ..... R113  
KM-21367 ..... R113  
KM-214/6 ..... R112  
KM-21435 ..... R112  
KM-259 ..... R111  
KM-26085 ..... R111  
KM-26735 ..... R113  
KS-85/SW ..... R114
- L**  
L-RAY/1000 ..... R108  
LC-31 ..... R81  
LMS-808 ..... R81  
LR-1000U ..... R108  
LS-280/SW ..... R81  
LSP-102 ..... R81  
LTR-102 ..... R80
- M**  
MA-123 ..... R162  
MA-500 ..... R163  
MA-935 ..... R131  
MA-HPF ..... R162  
MA-PRS ..... R162  
MA-SW ..... R162  
MC-31 ..... R81  
MCC-100/RT ..... R123  
MCC-100/SW ..... R123  
MCC-300/RT ..... R123  
MCC-300/SW ..... R123  
MCC-50/RT ..... R123  
MCC-50/SW ..... R123  
MCC-600/SW ..... R123  
MCC-900/SW ..... R123  
MCCN-1000/SW ..... R123  
MCCN-150/SW ..... R123  
MCCN-300/SW ..... R123  
MCCN-600/SW ..... R123  
MCS-180 ..... R116  
MD-5000DR ..... R84  
MD-872 ..... R55  
MDH-6300 ..... R84  
MEC-100/BL ..... R122  
MEC-100/GE ..... R122  
MEC-100/GN ..... R122  
MEC-100/RT ..... R122  
MEC-100/SW ..... R122  
MEC-1000/BL ..... R122  
MEC-1000/SW ..... R122  
MEC-1500/SW ..... R122  
MEC-190/BL ..... R122  
MEC-190/GE ..... R122  
MEC-190/GN ..... R122  
MEC-190/RT ..... R122  
MEC-190/SW ..... R122  
MEC-20/BL ..... R122  
MEC-20/RT ..... R122  
MEC-20/SW ..... R122  
MEC-2000/SW ..... R122  
MEC-50/BL ..... R122  
MEC-50/RT ..... R122  
MEC-50/SW ..... R122  
MECN-100/BL ..... R122  
MECN-100/RT ..... R122  
MECN-100/SW ..... R122  
MECN-1000/BL ..... R122  
MECN-1000/RT ..... R122  
MECN-1000/SW ..... R122  
MECN-1500/SW ..... R122  
MECN-200/BL ..... R122  
MECN-200/RT ..... R122  
MECN-200/SW ..... R122  
MECN-2000/SW ..... R122  
MECN-600/BL ..... R122  
MECN-600/RT ..... R122  
MECN-600/SW ..... R122  
MECR-100/SW ..... R122

# Index

MECR-1500/SW . . . . .	R122	MR-408 . . . . .	R119	MZF-8648 . . . . .	R119	RLED-111USB . . . . .	R115	TG-10R/1 . . . . .	R24, R171
MECR-200/SW . . . . .	R122	MR-410 . . . . .	R119			RM-10SET . . . . .	R144	TG-10STX/1 . . . . .	R171, R24
MECR-2000/SW . . . . .	R122	MR-42LIGHT . . . . .	R120	<b>N</b>		RM-901 . . . . .	R144	TG-10T/1 . . . . .	R171, R24
MECR-50/SW . . . . .	R122	MR-6LIGHT . . . . .	R120	NM-43 . . . . .	R147	RM/DELTA-160 . . . . .	R33, R64	TG-64CH18 . . . . .	R20, R173
MECR-600/SW . . . . .	R122	MR-704 . . . . .	R118	NPL-302 . . . . .	R115	RP-900 . . . . .	R143	TG-98RA/5 . . . . .	R20, R170
MEGA-118SUB . . . . .	R107	MR-706 . . . . .	R118	NX-2 . . . . .	R151	RTF-1 . . . . .	R144	TG-98TA/5 . . . . .	R170, R20
MEGA-118SUBAK . . . . .	R107	MR-708 . . . . .	R118	NX-6 . . . . .	R151	RTF-20 . . . . .	R144	TK-350 . . . . .	R153
MEGA-215DSP . . . . .	R107	MR-710 . . . . .	R118	NX-8 . . . . .	R152	RTF-2U . . . . .	R144	TK-600 . . . . .	R153
MEGA-215SUB . . . . .	R107	MR-712 . . . . .	R118	NX-8.8 . . . . .	R152	RTF-3 . . . . .	R144	TM-10 . . . . .	R15
MEL-102/SW . . . . .	R123	MR-716 . . . . .	R118	NX-8S . . . . .	R152	RTF-UF20 . . . . .	R131	TM-11 . . . . .	R15
MEL-202/SW . . . . .	R123	MR-720 . . . . .	R118	NX-9 . . . . .	R151	RU-8011D/5 . . . . .	R136	TM-12DC . . . . .	R16
MEL-602/SW . . . . .	R123	MR-919DJ . . . . .	R116			RU-8011DB/5 . . . . .	R136	TM-15 . . . . .	R15
MEQ-115/SW . . . . .	R87	MR-DMIX20 . . . . .	R67	<b>P</b>		RU-8012DB/5 . . . . .	R136	TM-17 . . . . .	R14
MFE-212 . . . . .	R86	MS-20/SW . . . . .	R110	PAB-210MK2 . . . . .	R103	RU-850LTB/5 . . . . .	R137	TM-17M . . . . .	R14
MH-16 . . . . .	R163	MS-28 . . . . .	R111	PAB-212MK2 . . . . .	R103	RU-850LTH/5 . . . . .	R137	TM-22 . . . . .	R14
MH-22 . . . . .	R163	MS-40/SW . . . . .	R110	PAB-215MK2 . . . . .	R103	RU-850TB/5 . . . . .	R137	TM-25 . . . . .	R14
MH-36 . . . . .	R163	MS-50/SW . . . . .	R110	PAB-308M/SW . . . . .	R105	RU-850TH/5 . . . . .	R137	TM-27 . . . . .	R13
MH-56 . . . . .	R163	MS-60/SW . . . . .	R110	PAB-512/BL . . . . .	R102	RU-901G3/5 . . . . .	R134	TM-35 . . . . .	R13
MH-850/1 . . . . .	R140	MS-90/SW . . . . .	R110	PAB-512BAG . . . . .	R102	RU-G3TB/5 . . . . .	R134	TM-45 . . . . .	R13
MH-8800G/5 . . . . .	R135	MS-92/SW . . . . .	R110	PAB-515/BL . . . . .	R102	RU-G3TH/5 . . . . .	R134	TM-6 . . . . .	R15
MMC-1200/SW . . . . .	R123	MSC-1000/SW . . . . .	R125	PAB-515BAG . . . . .	R102			TM-929 . . . . .	R153
MMC-300/SW . . . . .	R123	MSC-1007/SW . . . . .	R125	PAK-10DMP . . . . .	R101	<b>S</b>		TXA-1000BAG . . . . .	R9
MMC-600/SW . . . . .	R123	MSC-102/SW . . . . .	R124	PAK-12DMP . . . . .	R101	SAM-2 . . . . .	R127	TXA-1000WPB . . . . .	R9
MMCN-1000/SW . . . . .	R123	MSC-105/SW . . . . .	R124	PAK-15DMP . . . . .	R101	SAM-200D . . . . .	R127	TXA-100HSE . . . . .	R11
MMCN-300/SW . . . . .	R123	MSC-110/SW . . . . .	R124	PAK-308M/SW . . . . .	R105	SAM-300D . . . . .	R127	TXA-100HT . . . . .	R11
MMCN-600/SW . . . . .	R123	MSC-115/SW . . . . .	R124	PAK-312M/SW . . . . .	R105	SAM-500D . . . . .	R127	TXA-1015ACCU . . . . .	R9
MMX-11USB . . . . .	R77	MSC-120/SW . . . . .	R124	PAK-410 . . . . .	R100	SGM-14 . . . . .	R157	TXA-1020 . . . . .	R4
MMX-30 . . . . .	R76	MSC-150/SW . . . . .	R125	PAK-412 . . . . .	R100	SIEM-111/5 . . . . .	R145	TXA-1020DMP . . . . .	R5
MMX-31 . . . . .	R76	MSC-1500/SW . . . . .	R125	PAK-415 . . . . .	R100	SIEM-111/R5 . . . . .	R145	TXA-1020MT . . . . .	R5
MMX-602/SW . . . . .	R76	MSC-202/SW . . . . .	R124	PAK-8DMP . . . . .	R101	SIEM-2/5 . . . . .	R145	TXA-1020MT . . . . .	R5
MPA-102 . . . . .	R82	MSC-205/SW . . . . .	R124	PAS-254D . . . . .	R11	SIEM-2/R5 . . . . .	R145	TXA-1020USB . . . . .	R4
MPA-202 . . . . .	R82	MSC-210/SW . . . . .	R124	PAST-120/SW . . . . .	R112	SONGWRITER-1 . . . . .	R35, R78	TXA-1022CD . . . . .	R4
MPR-1 . . . . .	R82	MSC-215/SW . . . . .	R124	PAST-122/SW . . . . .	R112	SP-15 . . . . .	R127	TXA-110 . . . . .	R11
MPR-6 . . . . .	R82	MSC-300/SW . . . . .	R125	PAST-122SET . . . . .	R113	SP-252E . . . . .	R127	TXA-12C . . . . .	R8
MPS-1 . . . . .	R81	MSC-502/SW . . . . .	R124	PAST-125/SW . . . . .	R112	SP-2RDP . . . . .	R127	TXA-15USB . . . . .	R10
MPX-1/BK . . . . .	R73	MSC-505/SW . . . . .	R124	PAST-125SET . . . . .	R113	SP-8/150PRO . . . . .	R127	TXA-1802CD . . . . .	R5
MPX-205/SW . . . . .	R74	MSC-510/SW . . . . .	R124	PAST-164/SW . . . . .	R112	SPR-6 . . . . .	R82	TXA-1822MR . . . . .	R5
MPX-20USB . . . . .	R77	MSC-515/SW . . . . .	R124	PAST-164SET . . . . .	R113	ST-5000 . . . . .	R161	TXA-36C . . . . .	R8
MPX-30DMP . . . . .	R73	MSC-520/SW . . . . .	R124	PAST-200/SW . . . . .	R112	ST-5000T . . . . .	R161	TXA-604/SW . . . . .	R12
MPX-410DMP . . . . .	R75	MSC-600/SW . . . . .	R125	PAST-25/SW . . . . .	R113	ST-5030 . . . . .	R161	TXA-624CD/SW . . . . .	R12
MPX-44/SW . . . . .	R75	MSCA-502/SW . . . . .	R124	PAST-250/SW . . . . .	R112	ST-5070 . . . . .	R161	TXA-700USB . . . . .	R10
MPX-622/SW . . . . .	R75	MSCA-505/SW . . . . .	R124	PAST-28/SW . . . . .	R113	ST-850 . . . . .	R161	TXA-800HSE . . . . .	R7
MR-102 . . . . .	R121	MSCA-510/SW . . . . .	R124	PAST-280SET . . . . .	R113	STA-1000 . . . . .	R91	TXA-800HT . . . . .	R7
MR-104 . . . . .	R121	MSCA-610/SW . . . . .	R124	PDM-3 . . . . .	R154	STA-1000D . . . . .	R94	TXA-800PS . . . . .	R8
MR-104DJ . . . . .	R117	MSCA-615/SW . . . . .	R124	PDM-57 . . . . .	R154	STA-1400 . . . . .	R91	TXA-800R . . . . .	R8
MR-106 . . . . .	R121	MSCA-620/SW . . . . .	R124	PODCASTER-1 . . . . .	R79, R35	STA-1500A . . . . .	R93	TXA-800ST . . . . .	R5
MR-106DJ . . . . .	R117	MSCN-8050/SW . . . . .	R125	PPA-100/SW . . . . .	R83	STA-1500A . . . . .	R93	TXA-802PS . . . . .	R8
MR-106PC . . . . .	R116	MSCN-8100/SW . . . . .	R125	PPA-4 . . . . .	R83	STA-1600DSP . . . . .	R90	TXA-802PS . . . . .	R8
MR-108 . . . . .	R121	MSCN-8150/SW . . . . .	R125	PROTON-15MK2 . . . . .	R109	STA-2000D . . . . .	R94	TXA-802SR . . . . .	R8
MR-108T . . . . .	R121	MSCP-1000/SW . . . . .	R125	PROTON-18NEO . . . . .	R109	STA-2200 . . . . .	R90	TXA-815ACCU . . . . .	R9
MR-10LIGHT . . . . .	R120	MSS-20/SW . . . . .	R111	PS-510M . . . . .	R163	STA-2200DSP . . . . .	R90	TXA-820 . . . . .	R6
MR-112DJ . . . . .	R117	MULTICOM-3SET . . . . .	R31	PSUB-12AKA . . . . .	R106	STA-225 . . . . .	R92	TXA-820BAG . . . . .	R9
MR-122 . . . . .	R118	MX-110 . . . . .	R77, R37	PSUB-15AKA . . . . .	R106	STA-235 . . . . .	R92	TXA-820CD . . . . .	R6
MR-162 . . . . .	R118	MX-210 . . . . .	R37, R77	PSUB-18L . . . . .	R106	STA-3000 . . . . .	R91	TXA-820MT . . . . .	R7
MR-162DESK . . . . .	R116	MXR-120 . . . . .	R70	PSUB-418AK . . . . .	R106	STA-300D . . . . .	R95	TXA-820WPB . . . . .	R9
MR-182 . . . . .	R118	MXR-120PRO . . . . .	R68	PT-850B/1 . . . . .	R141	STA-400D . . . . .	R95	TXA-822CD . . . . .	R6
MR-1918/SW . . . . .	R119	MXR-160 . . . . .	R70	PT-920BG/5 . . . . .	R135	STA-500 . . . . .	R92	TXB-602/SW . . . . .	R12
MR-246 . . . . .	R117	MXR-4 . . . . .	R72	PT-RMS . . . . .	R147	STA-500D . . . . .	R95	TXS-100BNC . . . . .	R58
MR-2LIGHT . . . . .	R121	MXR-40PRO . . . . .	R69			STA-553D . . . . .	R95	TXS-1800 . . . . .	R49
MR-3LIGHT . . . . .	R121	MXR-6 . . . . .	R72	<b>R</b>		STA-600 . . . . .	R91	TXS-1800HSE . . . . .	R49
MR-402 . . . . .	R119	MXR-60 . . . . .	R71	R-4/5 . . . . .	R132	STA-700 . . . . .	R92	TXS-1800HT . . . . .	R49
MR-403 . . . . .	R119	MXR-60PRO . . . . .	R69	R-4TBM/5 . . . . .	R133	STA-800D . . . . .	R94	TXS-1820 . . . . .	R49
MR-404 . . . . .	R119	MXR-80 . . . . .	R71	R-4THA/5 . . . . .	R132			TXS-1BNC . . . . .	R59
MR-404 . . . . .	R119	MXR-80PRO . . . . .	R68	RCS-18 . . . . .	R116	<b>T</b>		TXS-2401SX . . . . .	R57
MR-405TXS . . . . .	R117	MZF-8645 . . . . .	R119	RCS-85/SW . . . . .	R116	TG-10CH18 . . . . .	R173, R25	TXS-2402SET . . . . .	R57
MR-406 . . . . .	R119	MZF-8646 . . . . .	R119	RCS-92/SW . . . . .	R116	TG-10CH2 . . . . .	R173, R25	TXS-35BNC . . . . .	R58

TXS-606HSE/2.....	R47	W4-CH12.....	R165
TXS-606HT/2.....	R47	W4-CH12/COVER....	R165
TXS-606LT/2.....	R47	WA-35.....	R155
TXS-611SET.....	R56	WAP-5.....	R16
TXS-616SET.....	R56	WAP-8.....	R16
TXS-626.....	R46	WAVE-08A.....	R98
TXS-631SET.....	R56	WAVE-08P.....	R99
TXS-636SET.....	R56	WAVE-10A.....	R98
TXS-646.....	R46	WAVE-10P.....	R99
TXS-686.....	R46	WAVE-12A.....	R98
TXS-707.....	R50	WAVE-12P.....	R99
TXS-707HSE.....	R50	WAVE-15A.....	R98
TXS-707LT.....	R50	WAVE-15P.....	R99
TXS-70BNC.....	R58	WSA-24R.....	R45
TXS-727.....	R50	WSA-24T.....	R45
TXS-812SET.....	R57		
TXS-81ANT.....	R59	<b>X</b>	
TXS-82ANT.....	R59	XT70.....	R30
TXS-855.....	R51		
TXS-85ANT.....	R59		
TXS-865.....	R51		
TXS-865HSE.....	R51		
TXS-865HT.....	R51		
TXS-871.....	R52		
TXS-871HSE.....	R52		
TXS-871HT.....	R52		
TXS-875.....	R53		
TXS-875B.....	R58		
TXS-875DS.....	R59		
TXS-875HSE.....	R53		
TXS-875HT.....	R53		
TXS-891.....	R54		
TXS-891HSE.....	R54		
TXS-891HT.....	R54		
TXS-895.....	R55		
TXS-895HSE.....	R55		
TXS-895HT.....	R55		
TXS-900.....	R48		
TXS-900HSE.....	R48		
TXS-900HT.....	R48		
TXS-920.....	R48		

**U**

UA-960.....	R143
UB-9001.....	R143
UC-900.....	R143
UDA-49A.....	R142
UDA-49P.....	R142
UF-20R/5.....	R130
UF-20S/5.....	R130
UF-20TB/5.....	R131
ULM-164/SW.....	R76
US-8001D/1.....	R140
US-8001DBGY/5....	R141
US-8002D/1.....	R140
US-903DCPRO/5....	R135
USP-124.....	R143
USP-900.....	R142

**V**

VERT-12.....	R32, R97
VERT-12BAG.....	R97, R32
VU-800/SW.....	R87

**W**

W4-CH1.....	R165
-------------	------





All products of MONACOR INTERNATIONAL are tested continuously to ensure a constant quality level and to maintain quality standards. All products which are subject to the CE guidelines as well as the electric and electronic subassemblies which are subject to the directive for motor vehicles are tested according to the respective standards and carry the CE mark. These products can thus be sold in all EC countries without further tests or approvals.

## General Information

- All rights reserved by MONACOR INTERNATIONAL GmbH & Co. KG. All contents of this catalogue serve as information as to the products by MONACOR INTERNATIONAL only. No part of this catalogue including text, photos of products, graphics – or any parts thereof – may be reproduced in any form or by any means for any commercial use without our express prior written consent.
- \*Windows is a registered trademark of Microsoft Corporation in the United States and other countries.
- The software available on our websites is partly an 'Open Source Software' which is licenced under 'General Public License' (GPL). Further information can be found at the following link: <http://www.gnu.org/licenses/>.
- HDMI™ is a registered trademark of HDMI Licensing L.L.C.
- We cannot be held responsible for printing errors, should they occur. We reserve the right to make technical changes without prior notice.
- Specifications stated are according to information provided by the manufacturer.
- Due to production tolerances, technical data may vary slightly.
- Damage resulting from unauthorised servicing of the products thus causing changes as well as improper handling resulting in consequential damage are excluded from the warranty. We will not be liable for changes of the state of the products resulting from improper storage, other interventions or improper use.
- Lithium batteries have to meet special regulations for transportation and storage. Before dispatching such products, please pay attention to the safety notes in the section 'Downloads' on our website.
- If the devices are interfered with, the CE approval will no longer apply. All products are usually suitable for indoor use only, unless stated otherwise. The products are not suitable for installations into aircrafts or for surface mounting onto aircrafts.
- The devices do not correspond to the medical products directive 2007/47/EC.
- If the devices are permanently taken out of operation, they must be taken to a local recycling plant for disposal which is not harmful to the environment.

## Technical Information

- Before first use of the products, please read the instruction manual carefully!
- The products correspond to the directive for electromagnetic compatibility 2014/30/EU, the directive 2011/65/EU (RoHS) with the addition EU/2015/863 and where applicable to the low voltage directive 2014/35/EU with the directive 2009/125/EC (ErP) and the regulation 2019/1782.
- When operating with voltages of over 42 V, please always follow respective safety measures.
- Before opening any product operated with 230 V mains voltage, disconnect device from the mains.
- Make sure that the supply voltage is disconnected before working on components and modules. Existing capacitors must be discharged.
- Mains cables and test cables must be checked for damage on a regular basis. Never pull on the cable to disconnect the plug from the socket.
- Mains cables and fuses must only be replaced by skilled personnel.
- Unless otherwise stated:
  - protect the products from moisture and heat,
  - always observe the admissible ambient temperature of 0–40 °C.
- Do not use a very high volume level when using headphones. Permanent high volume may damage your hearing! Do not wear headphones while particular attention must be paid to your surroundings, e.g. in traffic.
- A soldering process which is too long and too hot may cause damage to the corresponding products. Choose a soldering temperature that is suitable for the material used. No liability can be assumed for damage to the product or consequential damage caused by improper handling.
- The plugs, jacks, switches, rotary switches and potentiometers shown in this catalogue are only suitable for connection to safety extra low voltage (SELV) or signal voltage unless the item is designed for a higher voltage (see text or table).
- If the fixing nuts of panel jacks or panel plugs are overtightened, it may cause damage to the whole component. In case of improper handling, no liability can be assumed for this or any consequential damage.
- The heat must be eliminated by air circulation. Therefore, do not cover ventilation slots with anything. Do not put or drop anything through the ventilation slots. Otherwise, there will be danger of an electric shock.
- Only use a dry, soft cloth for cleaning the products. Chemicals must not be used in any case.
- LED lights and LED lamps contain various components which may generate noise in unfavourable conditions. There may be audible resonances caused by installation, design of the lamp and the base as well as dimmer or transformer.

## Notes on Devices with Network/Internet Access

Please note that each device connected to a network with Internet access is part of a worldwide network. In order to protect your privacy and to prevent unauthorised people accessing your network and the devices connected, please protect your login details with an individual password prior to initial installation. Please take this into consideration when assigning future passwords in connection with devices, software and apps available in the network, e.g. when setting up user accounts. Passwords should never be disclosed to third parties! Furthermore, please note that any device which has been connected to the network should be reset before being sold or disposed of. This is the only way to ensure that all your personal data is erased permanently.

## Information on the German Product Liability Act

According to the law dated 15 December 1989 governing product liability which was last amended by the law dated 19 July 2002, manufacturers, importers and retailers are obliged to compensate for damage caused by a faulty product under certain prerequisites.

A product can already be considered faulty if its presentation leaves a private, non-commercial end user with a wrong impression as to its safety in use or if it is to be expected that the private end user will not observe the required safety regulations when using the product or will apply an excessive operating voltage to it, except if this user has been informed as to the necessity to observe the safety regulations and specified voltages, etc.

In your own interest and for your customers' safety, therefore please draw your non-commercial customers' attention to the following:

The products listed in this catalogue may only be used for the stated purpose. If there are any doubts as to the purpose of the goods, questions must be clarified with an authorised expert or with the service department of MONACOR INTERNATIONAL.

The following EN standards and VDE (Verband Deutscher Elektrotechniker = Association of German Electrical Engineers) regulations must be observed:

## Electromagnetic Compatibility:

EN300422, EN301489, EN55013, EN55103-1, EN55103-2, EN61000-3-2, EN61000-3-3, EN61000-6-1, EN61000-6-3

## Low Voltage Directive:

DIN VDE 0100, DIN VDE 0532, EN60065, EN60335, EN60598, EN60950, EN61010, EN62471

## Motor Vehicles Directive:

Directive 2004/104/EC

## In Germany, the above-mentioned regulations can be obtained from:

VDE-Verlag GmbH Bismarckstraße 33 10625 Berlin Germany Phone: +49 30 348001-0 Fax: +49 30 348001-9088	VDE-Verlag GmbH Postfach 120143 10591 Berlin Germany Phone: +49 30 348001-0 Fax: +49 30 348001-9088	VDE-Verlag GmbH Goethering 58 63067 Offenbach Germany Phone: +49 69 840006-0 Fax: +49 69 840006-1399
--	--	---

## Notes Regarding the Approval of Wireless Systems

The wireless microphone systems in the frequency ranges 863 MHz to 865 MHz and 2,4 GHz are generally approved and licence-free in the EU.

The wireless systems in the frequency range 506 MHz to 542 MHz, 518 MHz to 542 MHz, 672 MHz to 694 MHz are generally approved according to directive 34/2020 and are licence-free in Germany.

Every wireless system has been examined by a notified body and has been approved in the EU according to the RED directive. However, a frequency assignment for the systems in the frequency range 740 MHz to 776 MHz, 823 MHz to 832 MHz and 1.8 GHz for the corresponding area in which the device is to be used must be applied for at the respective national authority. There are restrictions or requirements within the EU.

In Germany, the frequency assignment has to be applied for at the corresponding branch of the Federal Network Agency (BNetzA, Germany).

The declaration of conformity can be found on our website: [www.monacor.com](http://www.monacor.com), [www.img-stageline.com](http://www.img-stageline.com) or [www.jts-europe.com](http://www.jts-europe.com). The forms for the frequency assignment can be found on the website of the Federal Network Agency [www.bundesnetzagentur.de](http://www.bundesnetzagentur.de). For countries outside of Europe, please consult the authorities of the corresponding country.

**Please observe the notes in the operating instructions.**

**MONACOR INTERNATIONAL GmbH & Co. KG; April 2020**

**MONACOR INTERNATIONAL – Your reliable partner – worldwide.**



THE AUDIO COMPANY

**HEADQUARTERS**  
**MONACOR INTERNATIONAL**  
Zum Falsch 36  
28307 Bremen  
Germany  
Tel.: +49 421 4865-0  
Fax: +49 421 488415  
info@monacor.com  
www.monacor-international.com

Your retailer



RETAIL  
K21-200REEN  
Order No. 1000230  
K-1158.02.01.01.2021

MONACOR and IMG STAGELINE are brands of the company group MONACOR INTERNATIONAL.

[www.monacor-international.com](http://www.monacor-international.com)