



Da-Lite Projection Screens

FOR YOUR IMAGE™



Content

Large venue projection screens



Arena Electrol (JumboKing) | page 4 | Studio Electrol (GiantKing) | page 5 | GiantScreen Electrol | page 6 |

Rental projection screens

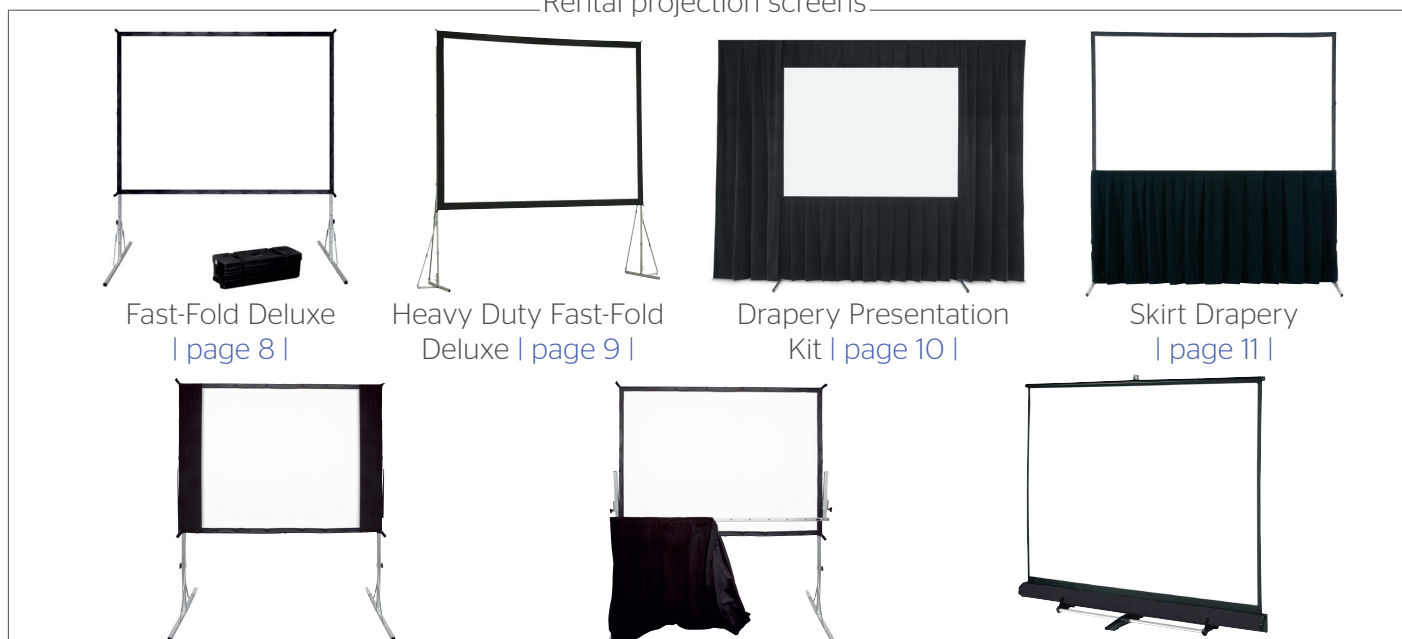

Fast-Fold Deluxe
| page 8 |

Heavy Duty Fast-Fold
Deluxe | page 9 |

Drapery Presentation
Kit | page 10 |

Skirt Drapery
| page 11 |

Masking Panels | page 11 |

Adjustable Skirt Bar | page 11 |

Carpeted Floor Screen | page 12 |

Fixed frame projection screen

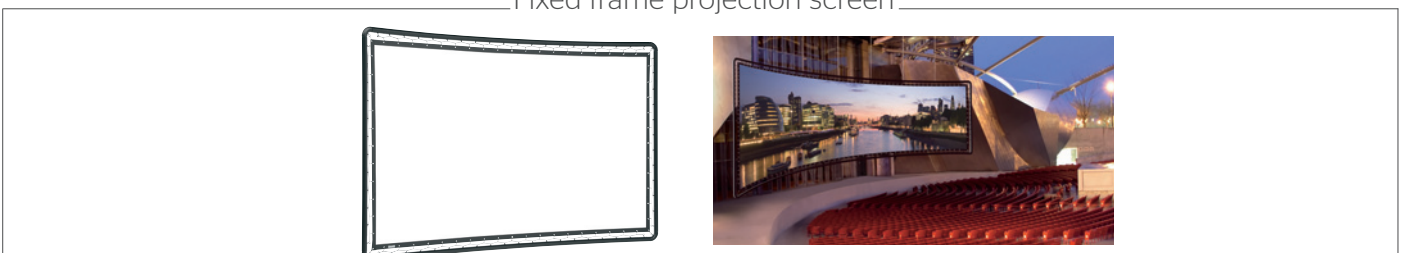

Series 200 / Series 300 | page 14 |

Rear projection screens



Da-Plex | page 16 |

Holo Screen | page 17 |

Da-Lite Projection Screens for Large Venues

Building large dimension projection screens demands craftsmanship. For more than 100 years Da-Lite has gained experience designing and manufacturing large motorized projection screens for large venues. Every projection screen produced is hand built and handled with a passion for quality, durability and safety.

Quality

We use the very best projection surfaces in our projection screens to obtain the best possible projection results. Furthermore we build our screens with durable materials to ensure a quality projection solution.



Durability

For the construction of our large dimension projection screens we use aluminum and steel components to ensure quality performance for years to come.

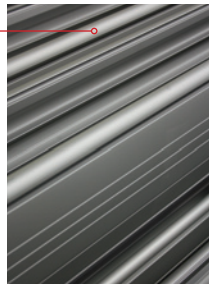

Safety

All electric large dimension projection screen motors are equipped with an automatic thermal overload cut-off and an electric brake to prevent coasting.

Customization

Large dimension projection screens are installed in various locations such as conference centers, auditoriums, concert halls and theatres. To obtain the best projection result it is imperative that the screen exactly fits the room and the projection requirements. Since our projection screens are hand built we can customize every screen in our extensive range to ensure the optimal projection solution.

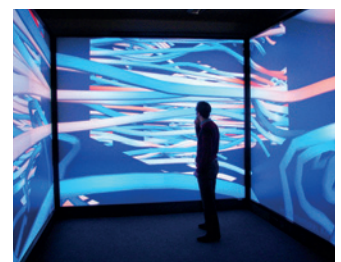

Arena Electrol

Motorized projection screen - 12 meters wide by 6 meters height maximum



Customized to your request



The Arena Electrol® is the solution to your large venue motorized projection screen needs.

- Robust case with a powerful motor and Polichinelle, which is a unique motorized cable and pulley system.
- The Polichinelle system guarantees a safe, taut and horizontal screen projection surface even in the largest sizes.
- The case and the projection screen surface can be made to exactly the right size.
- Available with matte white or matte white Sound projection screen surfaces.
- The Arena Electrol is supplied with a RF remote control as standard.
- The screen is mounted using mounting brackets on the top or to the rear of the case. Depending on the length of the case, the screen is supplied with up to four brackets.
- Also available with a rear projection screen surface in addition to matte white. The seam in the rear projection screen surface may be slightly visible under projection.
- The motor is equipped with electric locks to prevent inadvertent unrolling and features thermal overload cut-off.

Polichinelle System

In a standard projection screen, the weight of the slat bar, along with other elements, ensure that the projection screen surface remains properly tensioned. The Polichinelle system reverses the usual situation to achieve the correct tension. With this system, the projection screen surface rolls up around the slat bar which is retracted by two steel cables. This system can be adjusted both in the case and the slat bar, ensuring that the projection screen surface is smooth and taut under tension. The Polichinelle System ensures the flattest possible screen surfaces for sizes over 8 meters wide and is the ideal choice for auditoriums, theaters and other large venues.

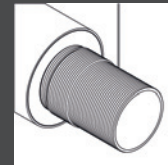

Matte White projection surface in this projection screen is a vinyl based material without black backing.

Studio Electrol

Motorized projection screen - 10 meters wide by 6 meters height maximum



The Studio Electrol is ideal for large screen applications including auditoriums, stages, arenas and multi-purpose rooms.

- Robust case with a powerful motor.
- Limit switches are factory set guaranteeing a long life span. The Studio Electrol is supplied with a wall switch.
- The screen is mounted using two flexible mounting brackets on the top or to the rear of the case. An optional third mounting bracket is available.
- The motor is equipped with electric locks to prevent inadvertent unrolling and features thermal overload cut-off.
- The underside of the case is open as standard. A closed version can be supplied at additional cost.
- Also available with a rear projection screen surface in addition to matte white. The seam in the rear projection screen surface may be slightly visible under projection.
- The case and the projection screen surface can be made to exactly the right size.



Aluminium case

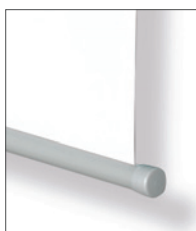

Rounded slat bar



Dimensions and product codes on page 19



Matte White projection surface in this projection screen is a vinyl based material without black backing.

GiantScreen Electrol

Motorized projection screen - 7 meters wide by 5 meters height maximum

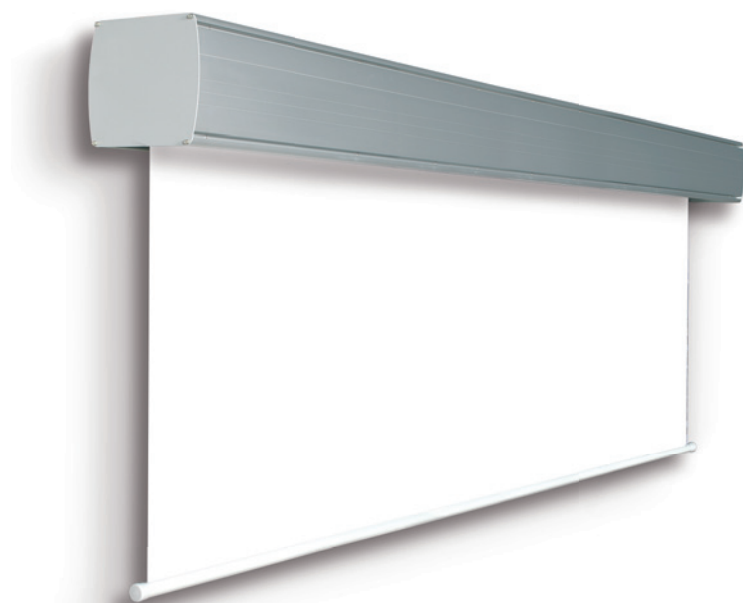

The first choice for medium to large size venues.

- Robust case with a powerful motor.
- Limit switches are factory set guaranteeing a long life span. The GiantScreen Electrol is supplied with a wall switch.
- The projection screen is mounted to the wall and/or ceiling using two brackets which can be positioned flexibly. The brackets can be positioned up to one meter from each side.
- The motor is equipped with electric locks to prevent inadvertent unrolling and features thermal overload cut-off.
- The underside of the case is open as standard. A closed version can be supplied at additional cost.
- Also available with a rear projection screen surface in addition to matte white. The seam in the rear projection screen surface may be slightly visible under projection.
- The case and the projection screen surface can be made to exactly the right size.



Robust case with a powerful motor.

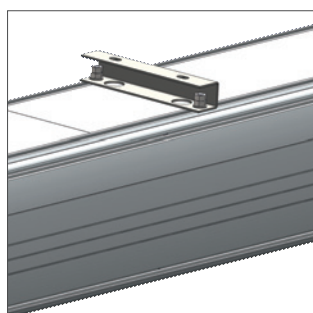

Adjustable mounting brackets



Matte White projection surface in this projection screen is a vinyl based material without black backing.



Building large dimension projection screens demands craftsmanship.



Fast-Fold® Deluxe

Portable folding screen up to 427 cm widths for use at any location



Lightweight folding frame which is easy to set up without the use of tools.

- The Fast-Fold® Deluxe consists of a folding aluminium frame (32 x 32 mm), two detachable legs and a detachable projection screen surface which is attached to the frame by snaps.
- The Matte White projection screen surface includes black backing as standard.
- The frame height is adjustable to any required viewing height in increments of 15 cm.
- The Fast-Fold® Deluxe is supplied in a sturdy plastic travel case on wheels as standard.
- Drapery Presentation Kit, which is easy to attach to the frame, is available separately.
- All projection screen surfaces are seamless.
- Flexibility for use in front or rear applications with Matte White, Da-Tex®, Dual Vision and Ultra Wide Angle projection surfaces.

Also available:

- Replacement screen surfaces



Rugged aluminium
32 mm square tubing



Dimensions and
product codes
on page 20/21



Snap Latch hinge design

Heavy Duty Fast-Fold® Deluxe

Foldable projection screen - 8.3 meters wide by 5.5 meters height maximum



Portable and very sturdy, foldable screen up to 838 cm widths for large scale applications. Ideal for events.

- The Heavy Duty Fast-Fold® Deluxe consists of a sturdy, folding aluminum frame (89 x 32 mm), two detachable heavy duty (HD) legs and a detachable projection screen surface which is attached to the frame by snaps.
- The frame is easy to set up without the use of tools.
- Sturdy legs with side supports for extra stability.
- The frame height is adjustable to any required viewing height in increments of 15 cm.
- Projection screen surfaces are seamless up to heights of 4.8 meters.
- The Matte White projection screen surface includes black backing as standard.
- Extra-wide black border (15 cm) on projection screen surfaces.
- The Heavy Duty Fast-Fold® Deluxe is supplied with two or three robust plastic travel cases on wheels.
- Drapery Presentation Kit, which is easy to attach to the frame, is available separately.
- The frame and screen surface can be custom made to exactly the right size. Borders can be optionally supplied in white.

Also available:

- Replacement screen surfaces



Dimensions and product codes on page 22/23



Speedy Cranks, no tools required



Snap Latch hinge design

Draperies Presentation Kit

Provide a professional finish to your screen

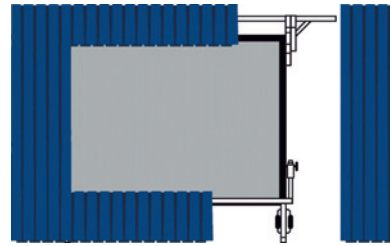

The drapery attaches with snaps

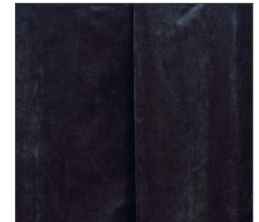

Ultra velour fabric

- The black Ultra Velour Drapery Presentation Kit provides a professional finish to the Heavy Duty Fast-Fold® Deluxe and Fast-Fold® Deluxe screens.
- Use a complete kit to create a uniform and aesthetically pleasing presentation system.
- The drapery attaches with snaps to Heavy Duty Fast-Fold® Deluxe and Fast-Fold® Deluxe drapery hardware. Optional black hardware is available.
- Drapery is fully box pleated for a polished appearance.
- The kit includes a valance bar, 36 cm high valance drape, wing bars, 81 cm wide wing drapes, a 114 cm long skirt that attaches to the screen surface without tools and a plastic travel case on wheels.
- In combination with the Fast-Fold® Deluxe, Heavy Duty legs are recommended to be used with the Drapery Presentation Kit for stability.
- The Ultra Velour fabric is inherently flame retardant and machine washable.

Skirt Drapery

Flame retardant & machine washable

- Fire retardant black Ultra Velour Drapery attaches with snaps to Heavy Duty Fast-Fold® Deluxe and Fast-Fold® Deluxe.
- The Skirt Drapery is standard 114 cm long.
- A customised skirt is available when the skirt has to be longer.
- The Ultra Velour fabric is inherently flame retardant and machine washable.

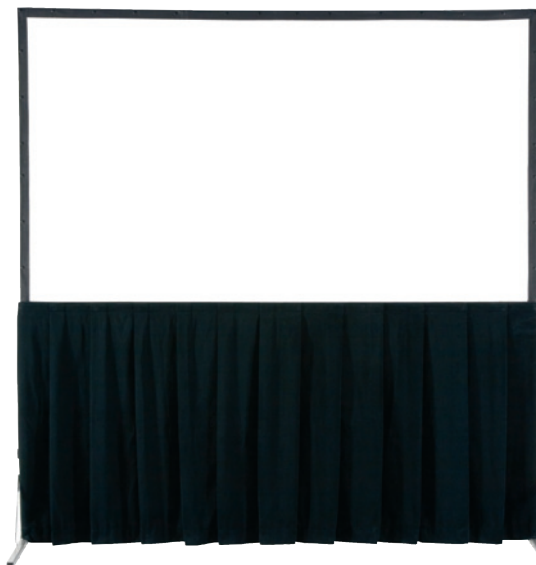

Easy set-up with studs

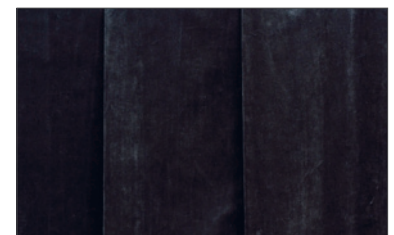

Ultra velour fabric



Masking Panels

Double the functionality of your screen



- Drapery Masking panels allow a native 16:9 Fast-Fold® screen to be properly masked to a 4:3 format, in effect doubling the functionality of the screen.
- Masking panels simply attach with Velcro® at the top and snap into place at the bottom of the screen to snap studs along the black binding.
- The masking panels are inherently flame retardant.



Double functionality: from 16:9 to 4:3 format



Dimensions and product codes on page 26

Adjustable Skirt Bar

Change and create the aspect ratio of your choice



- An optional Adjustable Skirt Bar is available to change the aspect ratio.
- The Adjustable Skirt Bar can be attached to the frame of the Heavy Duty Fast-Fold® Deluxe or Fast-Fold® Deluxe without tools.
- The Adjustable Skirt Bar can be moved along the bottom of the screen to create the required aspect ratio.
- The Adjustable Skirt Bar must be used in conjunction with Skirt Drapery to achieve masking.



Dimensions and product codes on page 27



Adjustable Skirt Bar attaches with snaps



Adjustable Skirt Bar bracket

Carpeted Floor Screen

The perfect solution for any presentation



A mobile solution ideal for rental, staging and hospitality applications.

- The Carpeted Floor Screen is positioned on the sturdy Floor Stand to complete a mobile solution ideal for rental, staging and hospitality applications.
- Carpeted Floor Screen stands up to the demands of any presentation.
- Screen pulls up from the case with reduced spring tension for easy raising and lowering.
- Black industrial grade carpeted case withstands the nicks and scratches of frequent use and transportation.
- The Floor Stand cradles the screen securely in place and offers a rigid, stable base. The Floor Stand needs to be ordered separately with the purchase of a Carpeted Floor Screen.

Accessories:

Floor Stand - 10830363



Carpeted Floor screen case



Carpeted Floor screen telescopic



Carpeted Floor screen cradle



Dimensions and product codes on page 28



Series 200 / Series 300

Lace and grommet screen - 27 meters wide maximum



Heavy duty lace and grommet tensioned screen up to 27 metres wide in front projection and 12 metres wide in rear projection, either straight or curved.

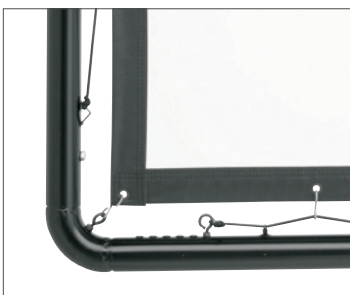

Robust tubular frame construction

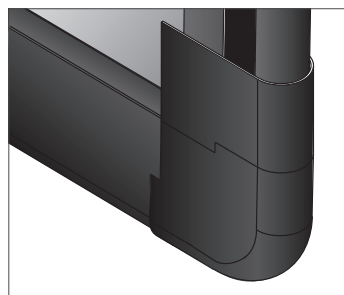

The frame can be finished with a black velvet edging.

Customized to your request





- The screen's robust tubular frame construction keeps the fabric taut, making it possible for the screen to be suspended freely from a truss construction for large events.
- The screen is also well suited for wall mounting and can even be mounted on legs.
- The Series 200 and 300 will be customised to project specifications.
- The curved version can be supplied with any degree of curvature based on a single axis.
- Suitable for any situation requiring special projection solutions, including custom shapes and sizes such as circles, trapezoid shapes and triangles.
- The frame can be attractively finished with a black velvet edging, whereby the black velvet prevents reflection and serves to absorb projected light.
- The frame is constructed of aluminium tubing with pre-mounted and pre-positioned tensioning cords and "S" hooks for easy mounting which are concealed by the velvet edging.
- The tubing diameter for the Series 200 is 5.1 cm with screens available up to a width of 9 metres.
- The tubing diameter for the Series 300 is 7.6 cm with screens available up to a width of 27 metres.
- The curved Series 200 or 300 is ideal for simulation and demonstration applications.
- The screen can be optionally packed in robust plastic travel cases on wheels.

Da-Plex

Da-Plex is available in standard sizes up to 251 cm and 427 cm wide



Gain; Indicates Goniophotometer reflectance readings. The higher the number, the greater light transmitted to the audience.

Viewing angle; number indicates the optimal width of the ideal full viewing angle.

Da-Plex is a rigid rear projection solution based on acrylic screen materials.

- Acrylic rigid screen materials offer high resolution diffusive reflection for permanent installations.
- The thin diffusion coating is permanently bonded to the acrylic substrate and cannot peel off like laminated film or vinyl based diffusion screens.
- Acrylic substrate for breakage resistance, light-weight, high optical quality, ease of handling and superior transmission.
- Da-Plex is available in standard sizes up to 251 cm and 427 cm wide. Larger sizes available upon request.
- The screen substrate is made of a clear acrylic plastic.
- The substrate has an optical coating on one surface that does not exceed 0.1 mm in thickness.
- Da-Plex rear projection screens are to be mounted with the coated surface towards the audience.
- Standard and Self-Trimming factory frame options are available.
- Da-Plex is standard with DA-100. Other coatings are available upon request.

Self trimming factory installed frame

Eliminates the need for finish trim for fast, easy

installation. Built-in 3.8 cm. wide molding to hide opening. Black anodized finish. Frame insert size equals screen viewing area plus 7.3 cm.

Standard factory installed frame

Impressive architectural design adds sophistication to any installation. 2.5 x 4.5 cm rectangular tube base. Dovetail frame eliminates light leakage. Black anodized finish. Frame insert size equals screen viewing area plus 10 cm.

Da-Plex Optical coatings

| DA-100 | DA-130 | DA-150 | DA-180 | DA-230 |
|-----------------------------|-----------------------------|-----------------------------|-----------------------------|-----------------------------|
| Gain 1.0 | Gain 1.3 | Gain 1.5 | Gain 1.8 | Gain 2.3 |
| Viewing angle 70° | Viewing angle 68° | Viewing angle 64° | Viewing angle 60° | Viewing angle 50° |

Wide Angle Optical coatings

| | |
|--|--|
| DA-75 Gain 0.75 Viewing angle 156° | DA-100 Gain 1.0 Viewing angle 104° |
|--|--|



Holo Screen

The Holo Screen is available in sizes up to 183 x 244 cm

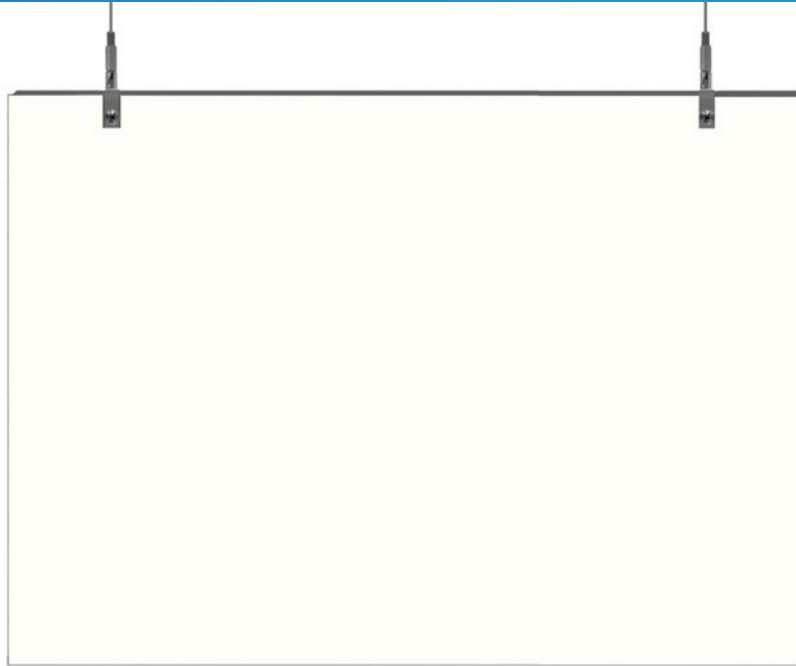

The Holo Screen is designed for point-of-sale applications in retail stores, window displays, airports, banks and other high traffic areas.

- The Holo Screen is a holographic rear projection screen for point-of-sale applications in retail stores, window displays, airports, banks and other high traffic areas. The transparent display allows viewers to look at and see through the screen.
- The Holo Screen is a single piece acrylic rear projection screen with a specially designed optical coating. This optical coating bonds to the acrylic so it will not crack, peel or become discolored.
- The Holo Screen features an advanced holographic technology that displays images rear projected from 18-35 degrees. The result is a remarkably bright and clear image - even in brightly lit environments.
- The Holo Screen is available in sizes up to 183 x 244 cm. Custom sizes are available upon request.
- The Holo Screen includes an aluminum extruded top and bottom frame for ease of installation. Adjustable and lockable fasteners and stainless steel cables complete the installation.



Index of all charts

Large venue projection screens

| | |
|-----------------------------|----------------------------|
| Arena Electrol (JumboKing) | customized to your request |
| Studio Electrol (GiantKing) | 19 |
| GiantScreen Electrol | 19 |

Rental projection screens

| | |
|--|-------|
| Fast-Fold® Deluxe | 20/21 |
| Fast-Fold® Deluxe replacement screen surfaces | 20/21 |
| Heavy Duty Fast-Fold® Deluxe | 22/23 |
| Heavy Duty Fast-Fold® Deluxe replacement screen surfaces | 22/23 |
| Drapery Presentation Kit for Fast-Fold Deluxe | 24 |
| Drapery Presentation Kit for Heavy Duty Fast-Fold Deluxe | 24 |
| Skirt Drapery for Fast-Fold® Deluxe | 25 |
| Skirt Drapery for Heavy Duty Fast-Fold® Deluxe | 25 |
| Masking Panels for Fast-Fold® Deluxe | 26 |
| Masking Panels for Heavy Duty Fast-Fold® Deluxe | 26 |
| Adjustable Skirt Bar for Fast-Fold® Deluxe | 27 |
| Adjustable Skirt Bar for Heavy Duty Fast-Fold® Deluxe | 27 |
| Carpeted Floor Screen | 28 |

Fixed frame projection screens

| | |
|------------------------|----------------------------|
| Series 200/ Series 300 | customised to your request |
|------------------------|----------------------------|

Rear projection screens

| | |
|-------------|----|
| Da-Plex 29 | |
| Holo Screen | 29 |



Studio Electrol (page 4)

| Aspect Ratio | Overall Dimensions | Overall Case Length | Net Weight | Screen Surfaces | | |
|--------------|--------------------|---------------------|------------|-----------------|-------------------|-----------------|
| | | | | Matte White | Matte White Sound | Rear Projection |
| | H x W cm | mm | kg | Product Code | Product Code | Product Code |
| 16:10 | 469 x 750 | 7790 | 345 | 10130791 | 10130795 | 10130799 |
| | 500 x 800 | 8290 | 358 | 10130029 | 10130043 | 10130800 |
| | 532 x 850 | 8790 | 383 | 10130792 | 10130796 | 10130801 |
| | 563 x 900 | 9290 | 400 | 10130793 | 10130797 | 10130802 |
| | 594 x 950 | 9790 | 420 | 10130794 | 10130798 | 10130803 |
| 4:3 | 525 x 700 | 7290 | 330 | 10130784 | 10130786 | 10130788 |
| | 562 x 750 | 7790 | 350 | 10130785 | 10130787 | 10130789 |
| | 600 x 800 | 8290 | 360 | 10130033 | 10130046 | 10130790 |
| Other | 600 x 700 | 7290 | 335 | 10130028 | 10130042 | 10130804 |
| | 550 x 800 | 8290 | 359 | 10130031 | 10130044 | 10130805 |
| | 500 x 900 | 9290 | 390 | 10130034 | 10130047 | 10130806 |
| | 600 x 900 | 9290 | 400 | 10130037 | 10130049 | 10130807 |
| | 500 x 1000 | 10290 | 430 | 10130038 | 10130050 | 10130808 |
| | 550 x 1000 | 10290 | 435 | 10130039 | 10130051 | 10130809 |
| | 600 x 1000 | 10290 | 440 | 10130040 | 10130052 | 10130810 |



GiantScreen Electrol (page 6)

| Aspect Ratio | Overall Dimensions | Overall Case Length | Net Weight | Screen Surfaces | | |
|--------------|--------------------|---------------------|------------|-----------------|-------------------|-----------------|
| | | | | Matte White | Matte White Sound | Rear Projection |
| | H x W cm | mm | kg | Product Code | Product Code | Product Code |
| 16:10 | 375 x 600 | 6200 | 144 | 10130771 | 10130774 | 10130777 |
| | 407 x 650 | 6700 | 153 | 10130772 | 10130775 | 10130778 |
| | 438 x 700 | 7200 | 163 | 10130773 | 10130776 | 10130779 |
| 4:3 | 450 x 600 | 6200 | 142 | 10130061 | 10130769 | 10130770 |
| Other | 500 x 600 | 6200 | 147 | 10130084 | 10130780 | 10130782 |
| | 500 x 700 | 7200 | 168 | 10130071 | 10130781 | 10130783 |

Fast-Fold® Deluxe (page 8)

| Aspect Ratio | Overall Dimensions | Viewing Area | Nominal Diagonal | | Min. height | Max. height |
|--------------|--------------------|--------------|------------------|--------|-------------|-------------|
| | H x W cm | H x W cm | cm | inches | cm | cm |
| 16:10 | 157 x 244 | 147 x 234 | 296 | 117 | 162 | 292 |
| | 174 x 274 | 164 x 264 | 330 | 130 | 179 | 309 |
| | 196 x 305 | 186 x 295 | 370 | 146 | 201 | 331 |
| | 234 x 366 | 224 x 356 | 442 | 173 | 239 | 369 |
| 16:9 | 142 x 244 | 132 x 234 | 269 | 106 | 147 | 277 |
| | 157 x 274 | 147 x 264 | 302 | 119 | 162 | 272 |
| | 175 x 305 | 165 x 295 | 338 | 133 | 180 | 310 |
| | 211 x 366 | 201 x 355 | 404 | 159 | 216 | 346 |
| | 244 x 427 | 234 x 417 | 483 | 190 | 259 | 389 |
| 4:3 | 160 x 213 | 150 x 203 | 254 | 100 | 165 | 295 |
| | 183 x 244 | 173 x 234 | 305 | 120 | 188 | 316 |
| | 228 x 305 | 218 x 295 | 381 | 150 | 233 | 363 |
| | 274 x 366 | 264 x 356 | 457 | 180 | 279 | 409 |
| | 320 x 427 | 310 x 417 | 508 | 200 | 325 | 500 |
| 1:1 | 213 x 213 | 203 x 203 | | | 218 | 348 |
| | 244 x 244 | 234 x 234 | | | 249 | 379 |
| | 274 x 274 | 264 x 264 | | | 279 | 409 |
| | 305 x 305 | 295 x 295 | | | 310 | 485 |
| | 366 x 366 | 356 x 356 | | | 371 | 546 |
| 3:2 | 213 x 320 | 203 x 310 | | | 218 | 348 |



| | Screen Complete | | | | Replacement screen surfaces | | | |
|--|-----------------|-----------|-------------|------------------|-----------------------------|-----------|-------------|------------------|
| | Matte White | Da-Tex® | Dual Vision | Ultra Wide Angle | Matte White | Da-Tex® | Dual Vision | Ultra Wide Angle |
| | prod.code | prod.code | prod.code | prod.code | prod.code | prod.code | prod.code | prod.code |
| | 10530635 | 10530636 | 10530637 | 10530638 | 10530681 | 10530682 | 10530683 | 10530684 |
| | 10530639 | 10530640 | 10530641 | 10530642 | 10530685 | 10530686 | 10530687 | 10530688 |
| | 10530643 | 10530644 | 10530645 | 10530646 | 10530689 | 10530690 | 10530691 | 10530692 |
| | 10530647 | 10530648 | 10530649 | 10530650 | 10530693 | 10530694 | 10530695 | 10530696 |
| | 10530236 | 10530240 | 10530627 | 10530628 | 10530244 | 10530248 | 10530673 | 10530674 |
| | 10530237 | 10530241 | 10530629 | 10530630 | 10530245 | 10530249 | 10530675 | 10530676 |
| | 10530238 | 10530242 | 10530631 | 10530632 | 10530246 | 10530250 | 10530677 | 10530678 |
| | 10530239 | 10530243 | 10530633 | 10530634 | 10530247 | 10530251 | 10530679 | 10530680 |
| | 10530819 | 10530820 | 10530821 | 10530822 | 10530823 | 10530824 | 10530825 | 10530826 |
| | 10530069 | 10530067 | 10530617 | 10530618 | 10530001 | 10530011 | 10530663 | 10530664 |
| | 10530071 | 10530070 | 10530619 | 10530620 | 10530003 | 10530013 | 10530665 | 10530666 |
| | 10530080 | 10530079 | 10530621 | 10530622 | 10530006 | 10530017 | 10530667 | 10530668 |
| | 10530096 | 10530099 | 10530623 | 10530624 | 10530022 | 10530026 | 10530669 | 10530670 |
| | 10530089 | 10530087 | 10530625 | 10530626 | 10530010 | 10530020 | 10530671 | 10530672 |
| | 10530074 | 10530073 | 10530651 | 10530652 | 10530002 | 10530012 | 10530697 | 10530698 |
| | 10530083 | 10530082 | 10530653 | 10530654 | 10530004 | 10530015 | 10530699 | 10530700 |
| | 10530100 | 10530101 | 10530655 | 10530656 | 10530024 | 10530025 | 10530701 | 10530702 |
| | 10530085 | 10530084 | 10530657 | 10530658 | 10530007 | 10530018 | 10530703 | 10530704 |
| | 10530092 | 10530091 | 10530659 | 10530660 | 10530009 | 10530019 | 10530705 | 10530706 |
| | 10530077 | 10530076 | 10530661 | 10530662 | 10530005 | 10530016 | 10530707 | 10530708 |

Heavy Duty Fast-Fold® Deluxe (page 9)

| Aspect Ratio | Overall Dimensions | Viewing Area | Nominal Diagonal | | Min. height | Max. height | Number of suitcases |
|--------------|--------------------|--------------|------------------|------|-------------|-------------|---------------------|
| | H x B cm | H x B cm | cm | feet | cm | cm | |
| 16:10 | 285 x 437 | 255 x 407 | 481 | 16 | 320 | 502 | 2 |
| | 335 x 518 | 305 x 488 | 576 | 19 | 370 | 522 | 2 |
| | 374 x 579 | 344 x 549 | 649 | 21 | 409 | 607 | 2 |
| | 412 x 640 | 382 x 611 | 721 | 24 | 447 | 690 | 2 |
| | 437 x 681 | 407 x 651 | 768 | 25 | 472 | 700 | 2 |
| | 488 x 762 | 458 x 732 | 864 | 28 | 523 | 721 | 3 |
| | 535 x 838 | 505 x 808 | 953 | 31 | 570 | 813 | 3 |
| 16:9 | 259 x 437 | 229 x 406 | 467 | 15 | 294 | 492 | 2 |
| | 305 x 518 | 274 x 488 | 559 | 18 | 340 | 507 | 2 |
| | 335 x 579 | 305 x 549 | 622 | 20 | 370 | 583 | 2 |
| | 373 x 640 | 343 x 610 | 700 | 23 | 408 | 667 | 2 |
| | 396 x 681 | 366 x 650 | 747 | 25 | 411 | 685 | 2 |
| | 442 x 762 | 411 x 732 | 838 | 28 | 477 | 705 | 3 |
| | 488 x 838 | 458 x 808 | 934 | 31 | 523 | 782 | 3 |
| 4:3 | 305 x 396 | 274 x 366 | 457 | 15 | 310 | 523 | 2 |
| | 351 x 457 | 320 x 427 | 533 | 17 | 355 | 595 | 2 |
| | 396 x 518 | 366 x 488 | 610 | 20 | 401 | 678 | 2 |
| | 488 x 640 | 457 x 610 | 762 | 25 | 493 | 784 | 2 |
| | 579 x 762 | 549 x 732 | 915 | 30 | 584 | 950 | 3 |

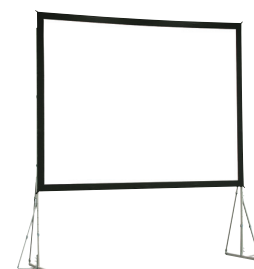

| | Screen Complete | | | | Replacement screen surfaces | | | |
|--|-----------------|-----------|-------------|------------------|-----------------------------|-----------|-------------|------------------|
| | Matwit | Da-TeX® | Dual Vision | Ultra Wide Angle | Matwit | Da-TeX® | Dual Vision | Ultra Wide Angle |
| | prod.code | prod.code | prod.code | prod.code | prod.code | prod.code | prod.code | prod.code |
| | 10530522 | 10530523 | 10530524 | 10530525 | 10530589 | 10530590 | 10530591 | 10530592 |
| | 10530526 | 10530527 | 10530528 | 10530529 | 10530593 | 10530594 | 10530595 | 10530596 |
| | 10530530 | 10530531 | 10530532 | 10530533 | 10530597 | 10530598 | 10530599 | 10530600 |
| | 10530534 | 10530535 | 10530536 | 10530537 | 10530601 | 10530602 | 10530603 | 10530604 |
| | 10530538 | 10530540 | 10530541 | 10530542 | 10530605 | 10530606 | 10530607 | 10530608 |
| | 10530543 | 10530544 | 10530545 | 10530546 | 10530609 | 10530610 | 10530611 | 10530612 |
| | 10530547 | 10530548 | 10530549 | 10530550 | 10530613 | 10530614 | 10530615 | 10530616 |
| | 10530494 | 10530495 | 10530496 | 10530497 | 10530561 | 10530562 | 10530563 | 10530564 |
| | 10530498 | 10530499 | 10530500 | 10530501 | 10530565 | 10530566 | 10530567 | 10530568 |
| | 10530502 | 10530503 | 10530504 | 10530505 | 10530569 | 10530570 | 10530571 | 10530572 |
| | 10530506 | 10530507 | 10530508 | 10530509 | 10530573 | 10530574 | 10530575 | 10530576 |
| | 10530510 | 10530511 | 10530512 | 10530513 | 10530577 | 10530578 | 10530579 | 10530580 |
| | 10530514 | 10530515 | 10530516 | 10530517 | 10530581 | 10530582 | 10530583 | 10530584 |
| | 10530518 | 10530519 | 10530520 | 10530521 | 10530585 | 10530586 | 10530587 | 10530588 |
| | 10530465 | 10530470 | 10530484 | 10530485 | 10530475 | 10530476 | 10530551 | 10530552 |
| | 10530466 | 10530471 | 10530486 | 10530487 | 10530041 | 10530033 | 10530553 | 10530554 |
| | 10530467 | 10530472 | 10530488 | 10530489 | 10530038 | 10530034 | 10530555 | 10530556 |
| | 10530468 | 10530473 | 10530490 | 10530491 | 10530031 | 10530035 | 10530557 | 10530558 |
| | 10530469 | 10530474 | 10530492 | 10530493 | 10530039 | 10530036 | 10530559 | 10530560 |



Drapery Presentation Kit (page 10)

Heavy Duty Fast-Fold® Deluxe Presentation kit

| Aspect Ratio | Overall Dimensions | |
|--------------|--------------------|-----------|
| | H x W cm | prod.code |
| 16:10 | 285 x 437 | 10830249 |
| | 335 x 518 | 10830250 |
| | 374 x 579 | 10830251 |
| | 412 x 640 | 10830252 |
| | 437 x 681 | 10830253 |
| | 488 x 762 | 10830254 |
| | 535 x 838 | 10830255 |
| 16:9 | 259 x 437 | 10830242 |
| | 305 x 518 | 10830243 |
| | 335 x 579 | 10830244 |
| | 373 x 640 | 10830245 |
| | 396 x 681 | 10830246 |
| | 442 x 762 | 10830247 |
| | 488 x 838 | 10830248 |
| 4:3 | 305 x 396 | 10830237 |
| | 351 x 457 | 10830238 |
| | 396 x 518 | 10830239 |
| | 488 x 640 | 10830240 |
| | 579 x 762 | 10830241 |

Fast-Fold® Deluxe Presentation kit

| Aspect Ratio | Overall Dimensions | |
|--------------|--------------------|-----------|
| | H x W cm | prod.code |
| 16:10 | 157 x 244 | 10830333 |
| | 174 x 274 | 10830334 |
| | 196 x 305 | 10830335 |
| | 234 x 366 | 10830336 |
| 16:9 | 142 x 244 | 10830329 |
| | 157 x 274 | 10830330 |
| | 175 x 305 | 10830331 |
| | 211 x 366 | 10830332 |
| 4:3 | 244 x 427 | 10830460 |
| | 160 x 213 | 10830324 |
| | 183 x 244 | 10830325 |
| | 228 x 305 | 10830326 |
| 1:1 | 274 x 366 | 10830327 |
| | 320 x 427 | 10830328 |
| | 213 x 213 | 10830337 |
| | 244 x 244 | 10830338 |
| | 274 x 274 | 10830339 |
| 3:2 | 305 x 305 | 10830340 |
| | 366 x 366 | 10830341 |
| | 213 x 320 | 10830342 |

Skirt Drapery (page 10)

Heavy Duty Fast-Fold® Deluxe Skirt Drapery

| Aspect Ratio | Overall Dimensions | |
|--------------|--------------------|-----------|
| | H x W cm | prod.code |
| 16:10 | 285 x 437 | 10830377 |
| | 335 x 518 | 10830378 |
| | 374 x 579 | 10830379 |
| | 412 x 640 | 10830380 |
| | 437 x 681 | 10830381 |
| | 488 x 762 | 10830382 |
| | 535 x 838 | 10830383 |
| 16:9 | 259 x 437 | 10830370 |
| | 305 x 518 | 10830371 |
| | 335 x 579 | 10830372 |
| | 373 x 640 | 10830373 |
| | 396 x 681 | 10830374 |
| | 442 x 762 | 10830375 |
| | 488 x 838 | 10830376 |
| 4:3 | 305 x 396 | 10830365 |
| | 351 x 457 | 10830366 |
| | 396 x 518 | 10830367 |
| | 488 x 640 | 10830368 |
| | 579 x 762 | 10830369 |

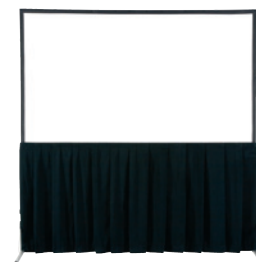

Fast-Fold® Deluxe Skirt Drapery

| Aspect Ratio | Overall Dimensions | |
|--------------|--------------------|-----------|
| | H x W cm | prod.code |
| 16:10 | 157 x 244 | 10830314 |
| | 174 x 274 | 10830315 |
| | 196 x 305 | 10830316 |
| | 234 x 366 | 10830317 |
| | 142 x 244 | 10830310 |
| 16:9 | 157 x 274 | 10830311 |
| | 175 x 305 | 10830312 |
| | 211 x 366 | 10830313 |
| | 244 x 427 | 10830459 |
| 4:3 | 160 x 213 | 10830305 |
| | 183 x 244 | 10830306 |
| | 228 x 305 | 10830307 |
| | 274 x 366 | 10830308 |
| | 320 x 427 | 10830309 |
| | 213 x 213 | 10830318 |
| 1:1 | 244 x 244 | 10830319 |
| | 274 x 274 | 10830320 |
| | 305 x 305 | 10830321 |
| | 366 x 366 | 10830322 |
| 3:2 | 213 x 320 | 10830323 |



Masking Panels (page 11)

Heavy Duty Fast-Fold® Deluxe Masking Panels

| Height Masking panel | Overall dimensions | HDTV Viewing Area | Video Viewing Area | |
|----------------------|--------------------|-------------------|--------------------|------------|
| cm | H x W cm | H x W cm | H x W cm | prod. code |
| 259 | 259 x 437 | 259 x 437 | 229 x 305 | 10830190 |
| 305 | 305 x 518 | 274 x 488 | 274 x 366 | 10830191 |
| 335 | 335 x 579 | 305 x 549 | 305 x 406 | 10830192 |
| 376 | 376 x 640 | 343 x 610 | 343 x 457 | 10830193 |
| 396 | 396 x 681 | 366 x 650 | 366 x 488 | 10830194 |
| 442 | 442 x 762 | 411 x 732 | 412 x 549 | 10830195 |
| 488 | 488 x 838 | 457 x 808 | 457 x 610 | 10830196 |

Fast-Fold® Deluxe Masking Panels

| Height Masking panel | Overall dimensions | HDTV Viewing Area | Video Viewing Area | |
|----------------------|--------------------|-------------------|--------------------|------------|
| cm | H x W cm | H x W cm | H x W cm | prod. code |
| 142 | 142 x 244 | 132 x 234 | 132 x 175 | 10830258 |
| 157 | 157 x 274 | 147 x 264 | 147 x 196 | 10830259 |
| 175 | 175 x 305 | 165 x 295 | 165 x 221 | 10830260 |
| 211 | 211 x 366 | 201 x 356 | 201 x 267 | 10830261 |
| 244 | 244 x 427 | 234 x 417 | 234 x 312 | 10830461 |

Adjustable Skirt Bar (page 11)

Heavy Duty Fast-Fold® Deluxe Adjustable Skirt Bar

| Aspect Ratio | Overall Dimensions | |
|--------------|--------------------|-----------|
| | H x W cm | prod.code |
| 16:10 | 285 x 437 | 10830209 |
| | 335 x 518 | 10830210 |
| | 374 x 579 | 10830211 |
| | 412 x 640 | 10830212 |
| | 437 x 681 | 10830213 |
| | 488 x 762 | 10830214 |
| | 535 x 838 | 10830215 |
| 16:9 | 259 x 437 | 10830202 |
| | 305 x 518 | 10830203 |
| | 335 x 579 | 10830204 |
| | 373 x 640 | 10830205 |
| | 396 x 681 | 10830206 |
| | 442 x 762 | 10830207 |
| | 488 x 838 | 10830208 |
| 4:3 | 305 x 396 | 10830197 |
| | 351 x 457 | 10830198 |
| | 396 x 518 | 10830199 |
| | 488 x 640 | 10830200 |
| | 579 x 762 | 10830201 |



Fast-Fold® Deluxe Adjustable Skirt Bar

| Aspect Ratio | Overall Dimensions | |
|--------------|--------------------|-----------|
| | H x W cm | prod.code |
| 16:10 | 157 x 244 | 10830271 |
| | 174 x 274 | 10830272 |
| | 196 x 305 | 10830273 |
| | 234 x 366 | 10830274 |
| | 142 x 244 | 10830267 |
| 16:9 | 157 x 274 | 10830268 |
| | 175 x 305 | 10830269 |
| | 211 x 366 | 10830270 |
| | 244 x 427 | 10830463 |
| 4:3 | 160 x 213 | 10830262 |
| | 183 x 244 | 10830263 |
| | 228 x 305 | 10830264 |
| | 274 x 366 | 10830265 |
| | 320 x 427 | 10830266 |
| | 213 x 213 | 10830275 |
| 1:1 | 244 x 244 | 10830276 |
| | 274 x 274 | 10830277 |
| | 305 x 305 | 10830278 |
| | 366 x 366 | 10830279 |
| | 213 x 320 | 10830280 |
| 3:2 | | |



Carpeted Floor Screen (page 12)

| Accessories | prod. code |
|-------------|------------|
| Floorstand | 10830363 |

| Aspect Ratio | Overall Dimensions | Viewing Area | Nominal Diagonal | | Transport Length | Screen Surfaces |
|--------------|--------------------|--------------|------------------|--------|------------------|-----------------|
| | | | cm | inches | | Matte White |
| | H x W cm | H x W cm | cm | inches | cm | prod.code |
| 4:3 | 185 x 244 | 175 x 234 | 305 | 120 | 252 | 10530801 |
| | 231 x 305 | 221 x 295 | 381 | 150 | 313 | 10530802 |
| | 277 x 366 | 267 x 356 | 457 | 180 | 374 | 10530803 |
| 1:1 | 244 x 244 | | | | 252 | 10530804 |
| | 274 x 274 | | | | 283 | 10530805 |
| | 305 x 305 | | | | 313 | 10530806 |
| | 366 x 366 | | | | 374 | 10530807 |



Da-Plex (page 16)

| Aspect Ratio | Viewing Area | Nominal Diagonal | | Frames | |
|--------------|--------------|------------------|--------|----------------|---------------------|
| | | cm | inches | Standard Frame | Self Trimming Frame |
| | H x W cm | cm | inches | prod.code | prod.code |
| 16:9 | 103 x 183 | 208 | 82 | 10730085 | 10730102 |
| | 114 x 203 | 234 | 92 | 10730086 | 10730103 |
| | 132 x 234 | 269 | 106 | 10730087 | 10730104 |
| | 147 x 264 | 302 | 119 | 10730088 | 10730105 |
| | 165 x 295 | 338 | 133 | 10730089 | 10730106 |
| | 198 x 353 | 404 | 159 | 10730090 | 10730107 |
| | 240 x 427 | 490 | 193 | 10730091 | 10730108 |
| 4:3 | 91 x 122 | 152 | 60 | 10730075 | 10730092 |
| | 102 x 137 | 170 | 67 | 10730076 | 10730093 |
| | 110 x 147 | 183 | 72 | 10730077 | 10730094 |
| | 128 x 171 | 213 | 84 | 10730078 | 10730095 |
| | 147 x 196 | 244 | 96 | 10730079 | 10730096 |
| | 152 x 203 | 254 | 100 | 10730080 | 10730097 |
| | 183 x 244 | 305 | 120 | 10730081 | 10730098 |
| | 206 x 274 | 343 | 135 | 10730082 | 10730099 |
| | 229 x 305 | 381 | 150 | 10730083 | 10730100 |
| | 251 x 335 | 419 | 165 | 10730084 | 10730101 |

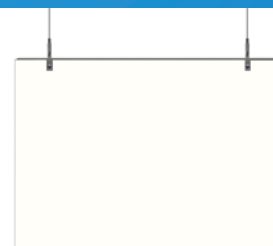

Holo Screen (page 17)

| Aspect Ratio | Overall Dimensions | Viewing Area | Nominal Diagonal | | Holo Screen | |
|--------------|--------------------|--------------|------------------|--------|-------------|----------|
| | H x W cm | H x W cm | cm | inches | | |
| 16:9 | 85 x 145 | 81 x 145 | 165 | 65 | 10 | 10730126 |
| | 99 x 170 | 95 x 170 | 196 | 77 | 12 | 10730127 |
| | 107 x 183 | 103 x 183 | 208 | 82 | 13 | 10730128 |
| | 118 x 203 | 114 x 203 | 234 | 92 | 17 | 10730129 |
| | 136 x 234 | 132 x 234 | 269 | 106 | 25 | 10730130 |
| 4:3 | 65 x 81 | 61 x 81 | 102 | 40 | 4 | 10730117 |
| | 80 x 102 | 76 x 102 | 127 | 50 | 6 | 10730118 |
| | 95 x 122 | 91 x 122 | 152 | 60 | 8 | 10730119 |
| | 106 x 137 | 102 x 137 | 170 | 67 | 10 | 10730120 |
| | 114 x 147 | 110 x 147 | 183 | 72 | 11 | 10730121 |
| | 132 x 171 | 128 x 171 | 213 | 84 | 16 | 10730122 |
| | 143 x 196 | 147 x 196 | 245 | 96 | 21 | 10730123 |
| | 156 x 203 | 152 x 203 | 254 | 100 | 23 | 10730124 |
| | 187 x 244 | 183 x 244 | 305 | 120 | 50 | 10730125 |



A Milestone Technologies Brand

3100 North Detroit Street
Warsaw, Indiana 46582
P: 574.267.8101 or 800.622.3737
F: 574.267.7804 or 877.325.4832
E: info@da-lite.com
www.da-lite.com

DL-0485

© 2014 Milestone AV Technologies LLC.

Europe, Middle East & Africa:
Milestone AV Technologies B.V.
Franklinstraat 14
6003 DK Weert
The Netherlands
P: +31 (0) 495 580 852
F: +31 (0) 495 580 845
E: emea.da-lite@milestone.com

All Da-Lite screens are made to order,
and can be customized to your needs.
To learn more, visit Da-Lite.com or call
+31 (0) 495 580 852 to chat with a
Da-Lite Customer Service Expert.