

NEW PRODUCTS

2020



ADB STAGELIGHT 
BY OSRAM

www.adbstagelight.com

INDEX

| | |
|---------------------------|----|
| HCR TECHNOLOGY..... | 3 |
| ORKIS PROFILE..... | 4 |
| ORKIS FRESNEL/PEBBLE..... | 6 |
| KLEMANTIS..... | 8 |
| LEXPERT FAMILY..... | 11 |
| LEXPERT PROFILE L..... | 12 |
| LEXPERT FRESNEL M..... | 14 |
| LEXPERT EMPHASY..... | 16 |

Cover: ADB with Liaoning Ballet - China



ADB luminaires provided with HCR technology

HCR TECHNOLOGY BY ADB

EVERY COLOR, EVERY NUANCE AND EVERY SHADE WITH THE HIGHEST CRI

The new HCR technology used in the newest ADB luminaires is an exclusive electronic platform developed by ADB and Claypaky in conjunction with Osram to meet the needs of lighting designers who were not fully satisfied with the performance of LED devices in comparison with traditional lamps, in particular because of their incomplete color range, poor color rendering index and lack of consistency. All these limitations have been now overcome, and it is finally possible to produce every

color, every nuance and every shade with satisfactory quality. The heart of the HCR Technology is a LED light source consisting of a module with six colors: besides the three "classic" basic RED, GREEN and BLUE colors, ADB has added AMBER, CYAN and LIME. This exclusive device provides a very wide color range with excellent color spectrum coverage.

The light produced by the HCR technology has a CRI reaching values that

have never been achieved before by LEDs: the typical CRI value is 97 and it goes up to 99. These values were previously possible only with traditional technology.

The ADB projectors based on the HCR technology are also extraordinary variable white LED units, from 8000K to 2500K: the white light they produce is extremely pure since it combines six colors, and the CRI is unaltered when the color temperature changes.

HCR TECHNOLOGY



PROPRIETARY 6-COLOR LED SOURCE:

R+G+B+Amber+Cyan+Lime

The six-color chip guarantees the highest CRI and a broader coverage of the Color Gamut

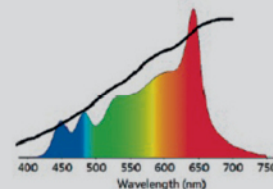
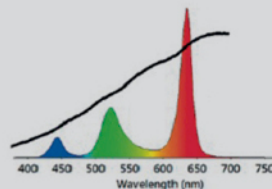

RGB(W) vs. 6-COLORS: AMBER, CYAN and LIME have been singled out as the perfect colors to complement the gaps in wavelength found in typical RGB systems.

EXCLUSIVE HCR TECHNOLOGY MAIN FEATURES

- Exclusive six-colour LED module: red, green, blue, cyan, lime and amber
- Wide range of colours and spectrum, including deep blue and deep red
- Smooth transition from one colour to another, which may be customized with a specific colour path
- White light may be adjusted from 2500K to 8000K, with very high CRI (between 97 and 99) and a similar spectrum to halogen light
- Tungsten mode, which reproduces the behaviour of a halogen lamp during adjustment from 0 to 100% and vice versa, including colour temperature change
- Hue correction: settings +/- green/magenta
- Ultra-smooth 16-bit dimming, with several dimmer curves available
- Three calibrated colour control modes: RGB, CMY and Hue-Saturation-Brightness
- Digital filters: more than 80 colours available, with reference to Lee Filters
- High colour stability and accuracy, even in Tungsten mode, thanks to its high resolution driver.



ORKIS PROFILE

SIX-COLOUR LED LUMINAIRE WITH INTERCHANGEABLE OPTICAL UNITS: THE ADVANCED TECHNOLOGY DEDICATED TO STAGE LIGHTING

The new ORKIS PROFILE based on the 6-colour HCR technology has been designed to meet the needs of the most demanding lighting designers in terms of dimming, colour mixing, variable white, beam uniformity and

light quality. It is fully compatible with the Orkis Fresnel, the Oksalis and the Klemantis, both in terms of colorimetry and colour control.

The Orkis Profile features zoom

optics consisting of a double lens combined with a single lens to prevent field distortion and chromatic aberrations. These lenses have a special anti-reflective coating, which ensures extremely high light output,



WEIGHT AND DIMENSIONS

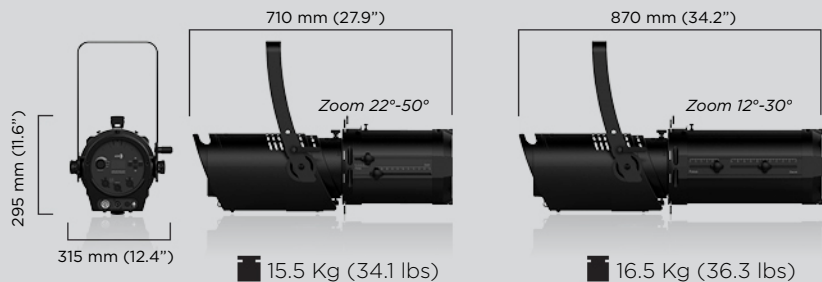



uniform light distribution and perfect sharpness.

The luminaire has a 4-shutter framing system and is designed to work with up to 6 shutters on three focal planes when necessary. All the blades have an anti-reflective coating. After adjustment, the shutters can be positioned in place thanks to a special locking system.

The two zoom units, 12-30° and 22-50°, can be simply swapped in a few seconds thanks to the unique «Fast Optical Mount» system. It can be done easily with the luminaire in any position. This unique system allows rotating the zoom, along with shutters

and gobo, freely and completely.

You may adjust the zoom and focus lenses freely and smoothly, from one side, while the luminaire is in any position, thus giving you highly precise control over the light beam. A graduated scale on the side along the tube allows you setting precisely the zoom and focus positions.

The body of the Orkis Profile is equipped with two guide rails which allow you to reposition the yoke to suit different situations. The special curved shape of

the yoke means the profile may be used hung or on the floor without interfering the shutters setting. Its locking system is quick and practical thanks to the single adjustable handle.



ELECTRICAL

- Power Supply: 90 - 260 V 50/60 Hz
- Max Consumption: 300 W
- «Flicker Free» with PWM frequency adjustment (1-50 KHz)

OPTICAL

- Light Source: 6-Color LED (Red, Green, Blue, Amber Cyan, Lime)
- CRI: 97 at any color temperature
- Color temperature range: 2500K - 8000K
- Zoom 12°-30°, interchangeable
- Zoom 22°-50°, interchangeable

CONTROL

- Control Modes: DMX 512, ArtNET, sACN, RDM
- Local control: Hue, Saturation, Intensity, CTO, Green-Magenta adjustment

- 16-bit ultra-smooth dimming
- Interface: color touch screen and 3 pushbutton encoders
- Color control modes: HSI, RGB, CMY

PHYSICAL

- Aluminum and metal die-cast housing
- Interchangeable Zoom optics
- 360° Zoom rotation
- Possibility to use 6 shutters simultaneously
- Innovative shutter locking system
- Body color: black
- Standard accessory:
 - Neutrik PowerCON TRUE1 1.5m power cable, bare ends
- Optional accessories:
 - Adjustable internal diffuser
 - Gobo holder (B-size Gobo)
 - Iris

WEIGHTS

- Body : 9.5 Kg (20.9 lbs)
- Zoom 12-30° : 7 Kg (15.4 lbs)
- Zoom 22-50° : 6 Kg (13.2 lbs)

PHOTOMETRY

| Beam 12°-30° | White 3200K |
|--------------|---------------|
| Narrow | 7306 lux @ 5m |
| Wide | 1535 lux @ 5m |
| Beam 22°-50° | White 3200K |
| Narrow | 2019 lux @ 5m |
| Wide | 606 lux @ 5m |



ORKIS FRESNEL/PEBBLE

HIGH QUALITY WHITE AND COLORED LIGHT,
SILENT OPERATION AND VERSATILITY AT YOUR SERVICE

The ORKIS is ADB's new color LED fresnel or pebble luminaire, which brings the modernity of innovative technology to the stage in a simple,

versatile, heavy duty unit. Its CRI remains stable at values of at least 97 thanks to a modern 6-color LED system and advanced software.

The Orkis's performance really comes into its own in color production: the color range obtainable is very wide, and every shade can truly be



WEIGHT AND DIMENSIONS

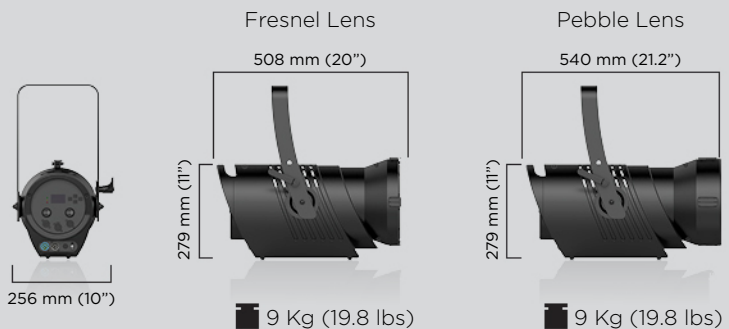



achieved. It faithfully reproduces the behaviour of a halogen light, making it compatible with various different light sources. The Orkis is also an extraordinary

variable white LED unit, from 8000K to 2500K: the white light it produces is extremely pure since it combines six colors, and the CRI is unaltered when the color temperature changes.

Its flexibility of use is remarkable: the fresnel version produces a flood light up to an angle of 87° (field angle), or a spot light with an angle of 15° (beam angle). Variation is continuous, smooth and linear within this range. Alternatively, the Orkis can be modified into a Pebble luminaire, by changing the lens with the related accessory or vice-versa. Modern, technologically advanced, versatile and extremely quiet, the Orkis can deliver high quality light in many applications: a complete solution for your rig.



ELECTRICAL

Power Supply: 90 - 260 V 50/60 Hz

OPTICAL

- Light source: 6-Color LED (Red, Green, Blue, Amber, Cyan, Lime)
- CRI: 97 at any color temperature
- Color temperature range: 2500K - 8000K
- Motorized zoom
- Fresnel lens:
 - Beam angle: 15° to 54°
 - Field angle: 22° to 87°
- Pebble lens:
 - Beam angle: 15° to 56°
 - Field angle: 26° to 80°

CONTROL

- Control modes: DMX 512, RDM, ArtNET

- Local control: Zoom, Intensity, CTO, Green-Magenta adjustment
- 16-bit ultra-smooth dimming
- IHM: color touch-screen & 3 push encoders
- Color control modes: Hue Saturation, RGB, CMY

PHYSICAL

- Aluminium & metal die-cast housing
- Color: black
- Standard accessories:
 - Metal filter frame 215 x 215 mm
 - Neutrik PowerCON TRUE1 1.5 m power cable, bare ends
- Optional accessories:
 - 8 leaves barndoors 215 x 215 mm

WEIGHT

9 Kg (19.8 lbs)

PHOTOMETRY

| Fresnel Lens | 3200K |
|--------------|---------------|
| Narrow | 2375 lux @ 5m |
| Wide | 305 lux @ 5m |
| Pebble Lens | 3200K |
| Narrow | 1668 lux @ 5m |
| Wide | 280 lux @ 5m |



KLEMANTIS

THE NEW CYCLIGHT BY ADB, WITH STATE-OF-THE-ART LED TECHNOLOGY

The new ADB KLEMANTIS is an asymmetric cyclight based on a six-color LED module, which uses cutting-edge HCR (high color rendering) LED technology to deliver a wide selection of colors from bold hues to pastel shades.

Thanks to an innovative algorithm, the unit is capable of achieving a stable CRI of over 97, as well as an impressive tunable white light ranging from 2500K to 8000K.

Its light output is enhanced by an innovative optical system, which enables the Klemantis to generate a uniform light with excellent diffusion and perfectly blended colors.

The KLEMANTIS units form a family of fixtures which are designed to be

used in linear arrays. The KLEMANTIS AS1000 is fitted with 16 multi-source LED modules and the KLEMANTIS AS500 with 8.

They can be used horizontally, vertically, laid on the floor, or hung from above on a bar. The AS500 is particularly suited for lighting cyc corners.

Unlike any other product on the market, the KLEMANTIS can be installed up to 60 cm from the cyclorama.

The Klemantis is a creative tool designed to meet today's lighting design needs. Its unique features and the unit's design reinvent the cyclorama concept, making it the perfect choice for any professional application.

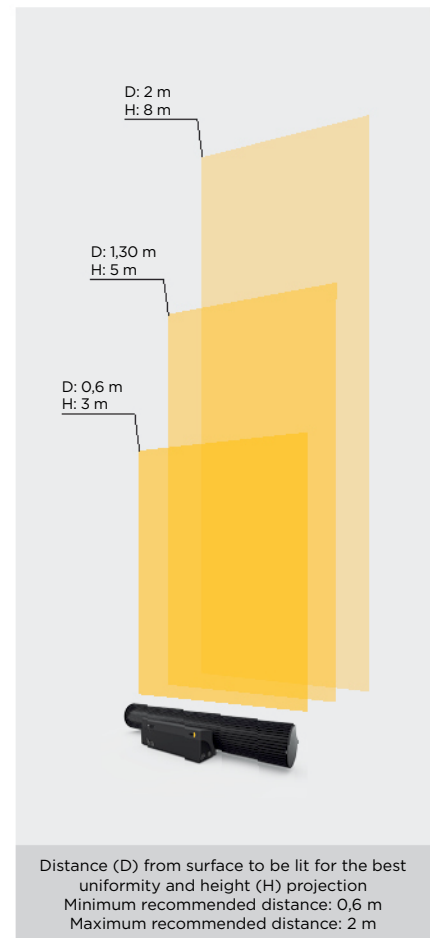

SPECIFICATIONS

- Beam type: asymmetric flood
- Very high CRI, >97 throughout the entire CCT (up to 99)
- Tunable white ranging from 2500K to 8000K, with perfect CCT
- Tungsten mode, to replicate the behaviour of a tungsten lamp during dimming from 0 to 100% and vice versa, including color temperature adjustment
- Tint correction: +/- green/magenta adjustments
- 16-bit ultra-smooth dimming, with different dimming curves available
- Exclusive LED module featuring six colors: red, green, blue, cyan, lime and amber
- Wide color gamut and extended spectrum, including deep blue and deep red
- Smooth color transition through different times, cross-fade and path options, and a gamma correction system
- Color control: hue saturation luminosity (HSL), CMY, RGB and RAW modes fully exploit the potential of the six-color system; wide selection of Digital filters (Color macros) which reproduce the spectrum of gel filters with tungsten bulbs

- High color stability and accuracy, also in tungsten mode, thanks to a high resolution driver
- Color consistency over time and temperature changes, thanks to combined fixture calibration and a LED ageing compensation algorithm
- Fixture to fixture color repeatability, thanks to tight wavelength binning selection and 100% fixture calibration
- Power supply: 100-240 V, 50/60 Hz
- Max power consumption: 280W (AS1000), 170W (AS500)
- Inputs: PowerCon IN, DMX 5 poles, USB Ethernet
- Outputs: PowerCon OUT, DMX 5 poles
- Daisy chain via PowerCon cable, max 5 KLEMANTIS AS 1000
- Connections IN and OUT for daisy chain, max 5 units
- Control protocols: DMX512, RDM, ArtNet, sACN
- Flicker-free, thanks to PWM frequency adjustment from 1 KHz to 50 KHz (10 Hz steps)
- LED cooling by natural convection

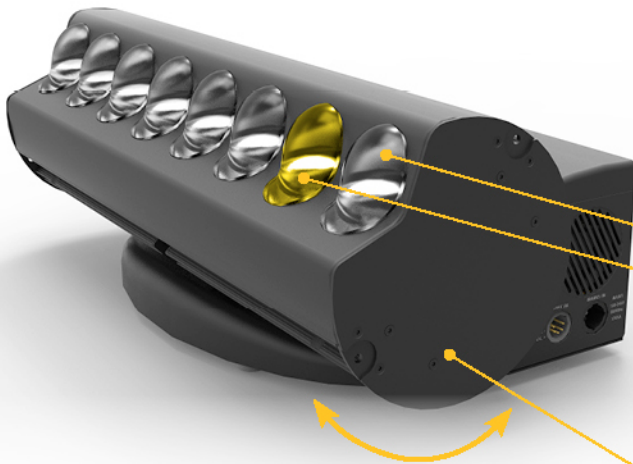

The fixture can be tilted on its base

DIMENSIONS

KLEMANTIS AS1000

LxWxH (mm): 1000 x 271 x 196

LxWxH (inches): 39.4 x 10.7 x 7.7

KLEMANTIS AS500

LxWxH (mm): 500 x 271 x 196

LxWxH (inches): 19.7 x 10.7 x 7.7

OPTICAL SYSTEM

Special optical chambers with reflective internal walls ("rods") convey the light output from each LED to the lens: this system generates perfectly mixed and uniform colors, without shadows or multi-colors at the output.

Enhanced ASYMMETRICAL LENSES for cyclorama lighting provide uniformity > 90% regardless of the cyclorama height.

Optional interchangeable SYMMETRIC LENSES turn your unit into a powerful straight beam of light.

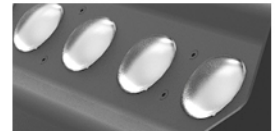

TUNGSTEN MODE

It's a special function which emulates the tungsten lamps: every parameter is set to emulate the performance of an incandescent bulb, specifically the dimming curve and the related color shift. Five different digital tungsten lamps are available.

COLOR MANAGEMENT

Klemantis features 4 operating modes: Raw Mode, HSL, RGB emulation and CMY emulation.

HSL mode is an innovative function allowing to manage both colors and white light, based on a complex, exclusive algorithm. In this mode, the CRI is kept constantly > 97, irrespective of color temperature.

COLOR LIBRARIES BASED ON GEL FILTERS

DMX channel for finding the color required, from among a huge selection based on color gels commonly used in the theatre.



Eurodim twin tech

**DON'T LIMIT YOUR INVESTMENT
TO ONLY 96 CHANNELS!**

- Up to 128 three-kilowatt channels.
- Designed for professional applications in theatres, concert halls and TV studios.
- More load per cabinet than any other dimmer on the market (3 kW configuration).
- The only one capable of operating either as a dimmer (0-100%) or as a static relay (ON-OFF switch), while protecting the components and ensuring the maximum lifespan of the connected equipment.
- Full control of all dimmer functions through a user friendly touchscreen interface.
- Automatic load balancing between all three phases.
- Three cooling fans to protect your lighting show.
- Premium quality and technical support guaranteed by ADB, part of the Osram/Claypaky group.

EURODIM TWIN TECH: YOUR BEST INVESTMENT FOR THE FUTURE.

MAIN ADB REFERENCES:

Opéra Bastille (France), Bolshoi Theatre (Russia, Moscow), Mariinsky Theatre (Russia, Saint Petersburg), Teatro Alla Scala (Italy), Beijing National Grand Theatre (China), renowned TV Studios and many more...



**THE POWER OF
384 kW
IN YOUR HAND**

REMOTE CONTROL FOR TWINTECH DIMMER

Download the "RDM Dimmer Remote" App
for iOS and Android



LEXPXPERT FAMILY

The LEXPERT family is a range of LED light projectors featuring advanced digital technology and extremely high quality light. LEXPERTs are designed for those who appreciate the advan-

tages of LEDs, but still prefer white light sources: a step towards the future, but with respect for the ways of those who have to use them.

LEXPXPERT is guaranteed by Osram's

long experience in the lighting industry, and jointly designed by ADB's R&D department. It provides all the benefits of high quality LED luminaires, with excellent value for money.





LEXP PERT PROFILE L

280W FIXED WHITE LED PROFILE SPOTLIGHT

The LEXPERT PROFILE is a white LED light able to produce a powerful, high quality light beam. The two versions available in the catalogue have different color temperatures: warm (3200K) or daylight (5600K). They are built to be modular: the body

containing the LED source works together with an optical unit with either a 15°-30° or a 25°-50° zoom. The two zoom modules are perfectly interchangeable with each other. The Lexpert Profile is equipped with a very versatile dimming system. You can

choose between 8 and 16 bit operation on five channels modes, with four preset dimmer curves. Alternatively intensity can be manually adjusted using an easily accessible knob on the back of the unit. The shaping system consists of four

WEIGHT AND DIMENSIONS

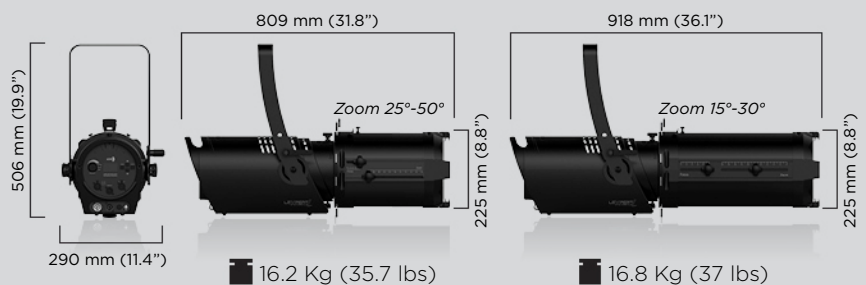

plates, which shape the light beam precisely. The unit also houses a gel holder for inserting color or frost filters, and a pattern holder, or an optional

18-blade iris.

The frequency of this very silent light may be set to between 600 and 4800 Hz and you may choose either

DMX512, RDM or ArtNet3 control. The Lexpert Profile is the ideal unit for lighting theatres, TV studios and multi-functional venues.

MAIN FEATURES

- Excellent smooth light output
- Interchangeable optical unit
- Two color temperatures: warm white (3200K) or daylight (5600K)
- Powerful high-quality beam (high CRI)
- Beam shaping system
- Gobo holder (gobo size Ø 90mm - image size Ø 75mm)
- Extremely smooth 16-bit dimming
- Strobe effect and gradients effect
- Excellent thermal design
- 4 fan selection: boost, standard, silent, ultra-silent
- Noise: 30 dB @ 1m in standard mode; under 25dB @ 1m in silent mode

LIGHT SOURCE

- 280W White LEDs

OPTICAL

- Zoom option: 15°-30° or 25°-50° (interchangeable)
- CRI: WW≥90; CW≥85

CONTROL

- DMX channels: 1/2/3/4/5, depending on the mode
- Control mode: DMX512, RDM, ArtNet
- Dimming adjustable manually via a rotating button
- Firmware upgrade: update via webpage with RJ45 socket

ELECTRICAL

- Power voltage: AC 100-240V, 50/60Hz
- Power consumption: 382 W
- Protection rating: IP20

PHOTOMETRY

| Beam | 3200K (warm white) |
|---------|-----------------------------------|
| 15°-30° | |
| Narrow | 9099 lux @ 4m (standard mode) |
| Wide | 2857 lux @ 4m (standard mode) |
| Beam | 3200K (warm white) |
| 25°-50° | |
| Narrow | 3570 lux @ 4m (standard mode) |
| Wide | 1159 lux @ 4m (standard mode) |
| Beam | 5600K (cool white) |
| 15°-30° | |
| Narrow | 10966 lux @ 4m (standard mode) |
| Wide | 3363 lux @ 4m (standard mode) |
| Beam | 5600K (cool white) |
| 25°-50° | |
| Narrow | 4050 lux @ 4m (standard mode) |
| Wide | 1365 lux @ 4m (standard mode) |

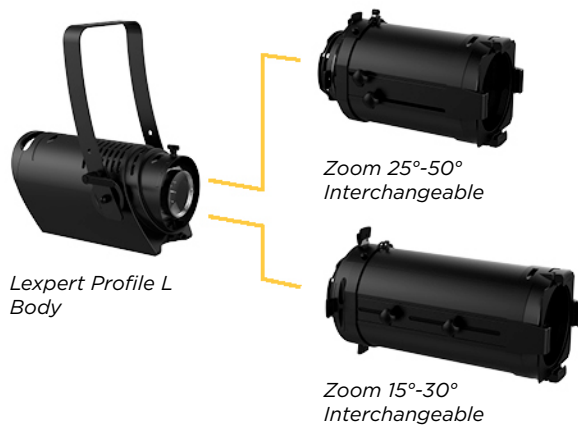

LCD Display

RJ45 socket IN Neutrik

Data IN/OUT: XRL 5 pins Neutrik

Power IN/OUT: Neutrik PowerCon

November 2019

Subject to change without notification





LEXP FRESNEL M

WHITE LED FRESNEL UNIT

The compact, lightweight LEXPERT FRESNEL M, with excellent heat dissipation and noise level of less than 30 dB, provides a powerful, smooth white LED light. Thanks to its 200 mm (nearly 8") high quality Fresnel lens

and motor-driven linear zoom, the Lexpert Fresnel M provides a uniform beam, which can be adjusted from 8 to 80 degrees using local and DMX controls.

It is equipped with a very versatile

dimming system: you can choose between 8 and 16-bit operation on four channels, with four preset dimmer curves. Alternatively it can be manually adjusted using an easily accessible knob on the back of the unit.



WEIGHT AND DIMENSIONS

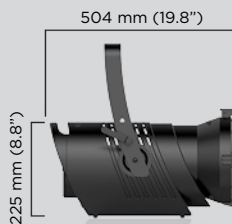
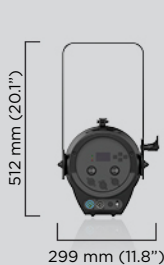

8.6 Kg (18.9 lbs)

The fixture can be ordered in two different color temperatures - warm (3200K) or daylight (5600K) - and features a gel frame and optional

8-leaves rotating barndoors. With a frequency selectable from 600 to 4800 Hz, and DMX512, RDM and ArtNet3 control to choose from, the

Lexpert Fresnel M is ideal for lighting theatres, TV studios, multi-purpose rooms and other venues.

MAIN FEATURES

- Excellent smooth light output
- High-quality light beam
- Excellent thermal design
- Two color temperatures: warm white (3200K) or daylight (5600K)
- Extremely wide 8°-80° linear motorized zoom
- Linear dimming (8/16 bit)
- Selectable frequencies: 600, 1200, 1800, 2400, 3000, 3600, 4200, 4800 Hz
- Strobe effect and gradients effect
- Optional rotating barndoors and hanger
- 4 fan selection: boost, standard, silent, ultra-silent
- Low noise: under 30 dB @ 1m

OPTICAL

- 200 mm high quality fresnel lens
- 100% Linear motorized zoom (8/16 bit)
- Beam angle: 8° - 80°
- CRI: WW≥94; CW≥90

LIGHT SOURCE

- 150W White LEDs

CONTROL

- DMX channels: 2/3/4/5/6 depending on the mode
- Control mode: DMX512, RDM, ArtNet3
- Dimming adjustable manually via a rotating button
- Zoom adjustable manually via a rotating button
- Firmware upgrade: update via webpage with RJ45 socket

ELECTRICAL

- Power voltage: AC 100-240V, 50/60Hz
- Max power consumption: 205W @ 230V
- Protection rating: IP20

PHOTOMETRY

| Beam | 3200K (warm white) |
|--------|----------------------------------|
| Narrow | 4320 lux @ 4m (standard mode) |
| Wide | 267 lux @ 4m (standard mode) |
| Beam | 5600K (cool white) |
| Narrow | 5436 lux @ 4m (standard mode) |
| Wide | 356 lux @ 4m (standard mode) |

LCD Display

Data IN/OUT: XRL 5 pins Neutrik

RJ45 socket IN Neutrik

Power IN/OUT: Neutrik PowerCon



November 2019

Subject to change without notification



LEXP

ERT EMPHASY

STYLISH, COMPACT YET VERY BRIGHT, FOR HIGHLIGHTING PRECIOUS DETAILS AND ARCHITECTURAL FEATURES

EMPHASY is an LED profile spot for accent lighting with an elegant, compact, lightweight design. The unit has built-in electronic control, and is fan-less for total silence. It is the perfect solution for all applications where the fixture cannot be hidden and an object or an architectural detail has to be enhanced; for instance in museums, art galleries, shop-windows, exhibition stands, restaurants,

hotel lobbies, churches and other commercial and entertainment venues.

EMPHASY features a high color rendering index (CRI≥95), stable over time, and a very high light output for its power consumption. The lens designed around the LED delivers a precise, sharp, perfectly diffused beam. The unit is available in various versions, with different



WEIGHT AND DIMENSIONS

EMPHASY ■ 1.8 Kg (3.9 lbs)

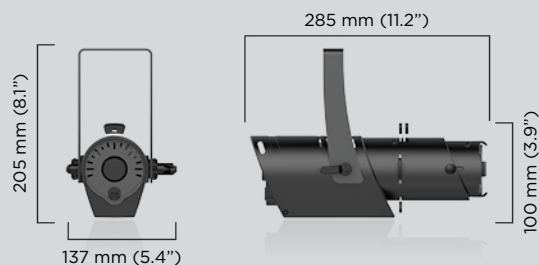

EMPHASY DMX (available on request) ■ 2 Kg (4.4 lbs)

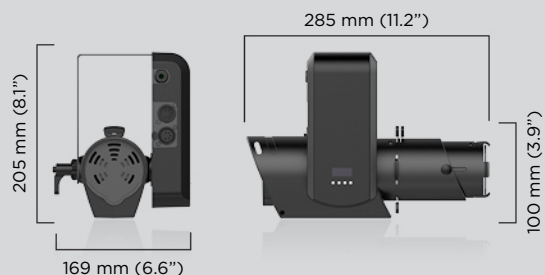

beam angles (19°, 26°, 36° or 50°), color temperatures (3200K or 5600K), body finishing color (black or white). A DMX version for

theatrical use is available. EMPHASY is guaranteed by Osram's long experience in the lighting industry and it has been jointly

designed by ADB and Claypaky's R&D departments. It provides all the benefits of LEDs with excellent value for money.

MAIN FEATURES

- Stylish design, sturdy, compact and lightweight
- Built-in electronic control
- Excellent thermal design without fans
- Enhanced optical design for a precise and uniform beam projection
- Powerful light output with a CRI \geq 95
- Beam shaping system
- Gobo holder included (gobo size \varnothing 30mm - image size \varnothing 24mm)
- Selection of 4 beam angles: 19°, 26°, 36° or 50°
- Available in 3200K or 5600K color temperature
- 0-100% smooth and precise dimming control
- Optional remote control via DMX signal available on request
- Accessories: filter frame holder, clamp, safety cable
- Adaptable to most common track lighting connectors (connector is not supplied)
- Available in black or white
- ETL & CE compliant

LIGHT SOURCE

- 36W high powerful LED
- High-quality, high-contrast lenses
- Perfect beam edge at any distance

CONTROL

- Dimming controlled via a rotating button or via DMX (optional)
- Firmware upgrade via DMX link (only DMX version)
- Data IN/OUT: XLR 5 pins Neutrik (only DMX version)

ELECTRICAL

EMPHASY

- Power at full intensity: 30W
- Voltage: 120-277VAC 50-60 Hz mains input via power cord with bare wires

EMPHASY DMX (available on request)

- Power at full intensity: 32W
- Voltage: 100-240VAC, 50/60 Hz mains input via power cord with bare wires

PHOTOMETRY

| Beam Angle | 3200K |
|------------|-------------------------------|
| 19° | 390 lux @ 5m 1080 lux @ 3m |
| 26° | 222 lux @ 5m 616 lux @ 3m |
| 36° | 142 lux @ 5m 395 lux @ 3m |
| 50° | 76 lux @ 5m 210 lux @ 3m |

| Beam Angle | 5600K |
|------------|-------------------------------|
| 19° | 436 lux @ 5m 1211 lux @ 3m |
| 26° | 244 lux @ 5m 678 lux @ 3m |
| 36° | 160 lux @ 5m 444 lux @ 3m |
| 50° | 88 lux @ 5m 244 lux @ 3m |



Enhanced optical design



Dedicated slot for filter frame

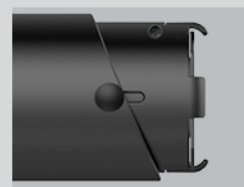

Beam shaping system and dedicated slot for gobo holder

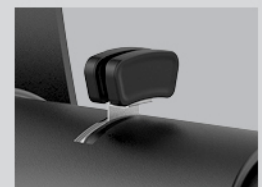

Dimming controlled via a rotating knob

November 2019

Subject to change without notification

ADB

DEVOTED TO THEATRE LIGHTING SINCE 1920



ADB, founded in 1920, was one of the pioneers of modern stage lighting. Its products are known and appreciated throughout the world for their construction quality, reliability and excellent performance, especially in the fields of theatre and television.

Since August 2016, ADB has become part of the Osram Group and merged its business with Claypaky, known for its multifunctional fixtures and unparalleled capacity for innovation.

ADB and Claypaky together set a benchmark today in the field of professional show lighting, owing to their unique capability of offering complete, integrated solutions for any kind of projects from television studios to theatres of all sizes, with a range of products including dimmers, fixed white LED luminaires and color LED luminaires.

ADB and Claypaky together are able to provide their international clientèle with a widespread organization capable of offering expert support in the design of lighting systems, their installation and commissioning. Above all they offer private customers and public institutions an unparalleled technical support.







Headquarters and Sales
Via Pastrengo, 3/b - I-24068 Seriate (BG), Italy - T +39.035.65.43.11
www.adbstagelight.com - info@adblighting.com