

User Manual of Chain Hoists



- Before installation and trial use of a hoist, please read the user manual carefully.
- Please keep the user manual well for subsequent use .

Content

1 SAFETY INSTRUCTIONS	2
2 INSTRUCTIONS ON CORRECT OPERATION AND MAINTENANCE.....	3
3 WARRANTY	4
4 ACCEPTANCE OF GOODS.....	5
5 DESCRIPTIONS-TECHNICAL CHARACTERISTICS	5
5.1 TYPE OF CHAIN HOISTS	5
5.2 MAIN LOCAL ACCESSORIES	6
5.3 OPERATION OF CHAIN HOISTS	8
5.4 DIMENSION AND WEIGHT OF CHAIN HOIST.....	8
5.5 CONNECTION ACCESSORIES OF CHAIN HOIST.....	8
5.6 ENVIRONMENTAL DATA	9
6 INSTALLATION.....	9
6.1 ELECTRICAL	10
6.2 HOISTING COMPONENTS	11
7 MAINTENANCE-REPLACEMENT	11
7.1 MAINTENANCE FORM	11
7.2 LUBRICATION	12
7.3 CHAINS	13
7.4 HOOKS.....	15
7.5 FORM ON REPLACEMENT OF SPARE PARTS.....	16
7.6 TECHNICAL FEATURES	17
7.7 HOIST SCRAPPING	17
8 TROUBLESHOOTING (3 PHASES).....	18

1 Safety Instructions

Warnings!

- Following safety instructions must be obeyed to prevent personal injuries or material damages!
- Don't let unqualified people to operate the hoist.
- Be sure to follow safety regulations (Clean personal protective equipment/work areas and indicate safety regulations in areas where these regulations must be followed.....)
- Be always ready to press the emergency stop button during operation to disable all functions.
- Don't operate the hoist beyond the maximum working load marked on the hoist. Vibration of load or accidental collision with objects generate extra load.
- Before operations, check whether the load is correctly fixed and mounted on the hook. The locking plate of the hook must be locked up correctly.
- Don't drive the hook rack to the bottom of the hoist. Don't drive the chain to be completely off the chain bag until the bump stop at the end of the chain touches the end of the hoist, or else the chain will be broken and the load will fall off.
- Don't carry people with the hoist.
- Don't twist the chain (e.g. rotate the hook rack.....)
- Don't transport load when there is any person nearby. Don't move the hook above people no matter it is loaded or not. Don't walk under the load.
- Don't shake the load deliberately.
- Don't shake the load deliberately.
- Don't disassemble the hook pin.
- Don't suspend the load on the clamp of the hook, or else the hook would be damaged to make the load fall off.
- The load must be always lifted up from the floor, and don't increase load of the hook that has been lifted up.

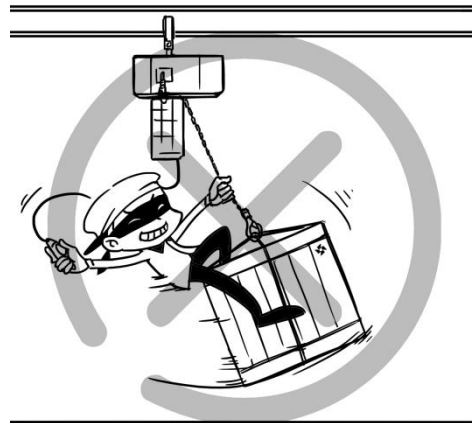

2 Instructions on Correct Operation and Maintenance

Obey following instructions to ensure good conditions of equipment and product safety.

- Don't move or lift up the hoist with cables.
- Don't put the hoist down in case of no supporting pedestal, in order not to damage the components under the hoist. (Cables, load chain, cable gland and chain bag.....).
- Only trained and authorized personnel are allowed to modify hoists. The numerical values and regulators of safety components must not be changed without the permission of manufacturer. Don't go beyond the limits indicated in the manual.
- Don't repair or modify hoists without the authorization of manufacturer or trained maintenance agents.
- Don't stop, regulate or disassemble limit switches or brakes on hoists without the authorization of manufacturer or trained maintenance agents.
- Don't drag, fluff or obliquely pull objects with hoists. Don't touch moving components.
- Don't operate hoists in case of physical discomfort.
- Don't use hoists that are not repaired well (damage or deformation.....).
- Don't make hoists subject to strenuous vibration.
- Don't use lifting chains as slings.
- Don't distract operators' attention while they are operating hoists.
- Don't suspend the load when unnecessary. Don't use hoists as earth wire for welding.
- Don't use hoists for other unexpected purposes and in other unexpected places.
- To move hoists by hands, it is necessary to push the load.
- Don't operate hoists with safety components such as buffers at the end and emergency stop.
- Don't exert unnecessary control (avoid inching - stop - start up with buttons), or else hoists will be overheated and even damaged.
- Don't operate hoists with unauthorized power supply (voltage is too low or too high without phase).
- Hoists must be handled with special structures or devices, or in original packages.
- Don't make hoists exposed to corrosive atmosphere(temperature, acidity.....).
- Make sure that hoists are always clean and kept from corrosion (lubrication.....).
- Hoists must be used under normal working conditions (ambient temperature and atmosphere.....). For outdoor operations, protective measures must be taken as far as possible to protect hoists from harsh weather conditions. Hoists must be covered well to prevent water from flowing into their chain bags. There must be scuppers at the bottom of chain bags.
- Store hoists in normal working position (without load) to protect them from corrosive atmosphere (dust and humidity).
- Hoists must be installed by professionals.
- Clean and lubricate moving components (chains included) according to this manual. Components of hoists must be replaced with genuine accessories suitable for models of hoists. Don't use suspicious parts or

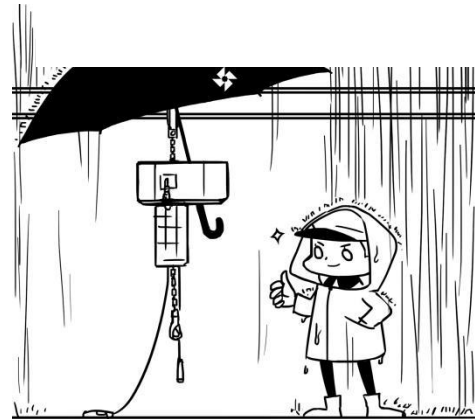

components of unknown sources.

- Make sure that limit switches are on correct position.
- Make sure that structures attached to hoists and those supporting hoists are rigid. Chain hoists must be regularly maintained according to this manual.
- Hoists must be regularly maintained according to this manual.
- Clean and lubricate moving components (chains included) according to this manual. Components of hoists must be replaced with genuine accessories suitable for models of hoists. Don't use suspicious parts or components of unknown sources.
- Don't obliquely pull the load, and the maximum allowable angle must be 10° .
- Confirm that the load has been correctly balanced before moving it, in order not to increase load only through a point. Use appropriate accessories such as slings and lifting beams.....). Pay attention to the center of gravity of handled load.
- The elements for hanging load must be independent of load (they should be soft slings at best rather than rigid beams).
- In moving the load, make sure that the load is lifted up to a height enough for it to keep away from surrounding machines and other objects. Make sure the hoist is perpendicular to the load before lifting the load up.
- Avoid swinging the load or hook in using little trolleys or cranes. If several different speeds are optional, the speed must be low during starting and braking operations.
- Moving a load with several hoists must be supervised by several experienced supervisors. All requisite preventive measures must be taken to ensure load distribution and avoid imposing excess load on any hoist. Before this operation, all hoists must be inspected carefully.
- In case of dangerous operations or problems with hoists (abnormal noise or movement.....), please notify necessary personnel.

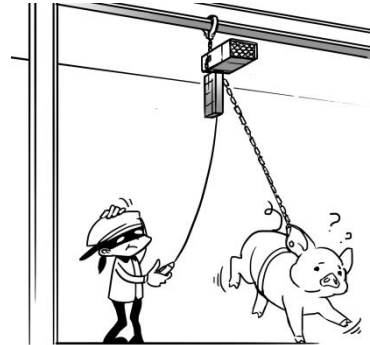

3 Warranty

- The quality of our electric chain hoists will be assured for a year from the date of delivery.
- If the delivery is delayed for reasons beyond the control of sellers, such delay shall not be longer than 3 months.
- A request must be made for extending the warranty accordingly (nor for more than 3 months each time) with written confirmation if the operation (installation) of the chain hoist is unavoidably delayed.
- Sellers must eliminate operational failures resulting from principles, manufacturing, components or materials.

Quality assurance neither covers normal wear nor failures caused by frequent and regular maintenance. It doesn't cover the damages arising from lack of supervision, misoperation, misuse of chain hoists, especially overload, side pull, too low/high voltage or wrong wiring.

- The quality assurance shall not prevail in the event that

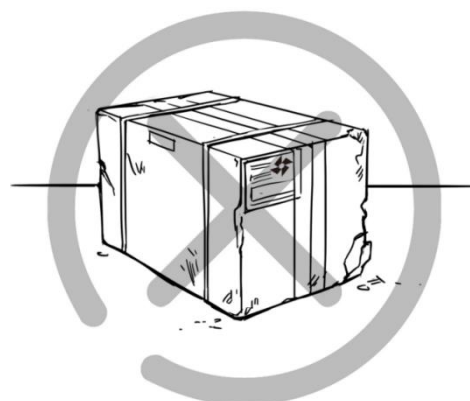

components such as machine parts or electronic elements are assembled, disassembled, modified or replaced without the prior consent of any authorized party or us.

- Within the warranty period, the sellers will freely replace or repair the damaged components tested and confirmed by qualified authorized technical service departments.
- Quality assurance doesn't cover any other services or compensations.
- Generally, the repairs covered by quality assurance shall be performed in workshops of sellers or authorized agents. The labor costs for assembly and disassembly must be borne by sellers or authorized agents .If the equipment is repaired by other personnel except for sellers or authorized agents or employees in places other than above workshops. The replaced components must be property of sellers and returned to sellers, while the fees for returning such disassembled and replaced components shall be assumed by sellers.

4 Acceptance of Goods

- Inspect appearances of packages to confirm they are intact, or else please notify the supplier according to requirements.
- Inspect if hoists conform to orders.
- For the convenience of transport, chain bags might be not assembled when they are delivered.

5 Descriptions-Technical Characteristics

5.1 Type of Chain Hoists

The serial number is indicated on the body of hoists and the nameplate of hoists outside electrical housing.

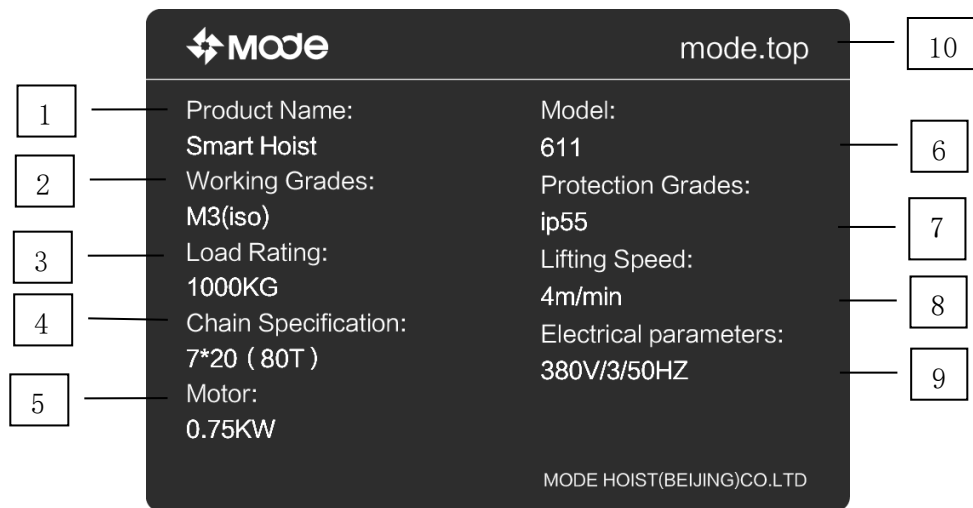

Nameplates of CSA-marked Chain Hoists

1	Product Name
2	Working Class of Mechanism
3	Allowable Minimum Load of Products
4	Chain Diameter and Pitch
5	Rated Motor Power
6	Actual Product Type
7	Protection Rating of Housing
8	High/Low Speed of Chain Hoists
9	Power Voltage and Frequency of Products, Number of Motor Phases
10	Universal Product Identification Number

Notes: The instance data shown in the above figure is only for demonstration.

5.2 Main Local Accessories

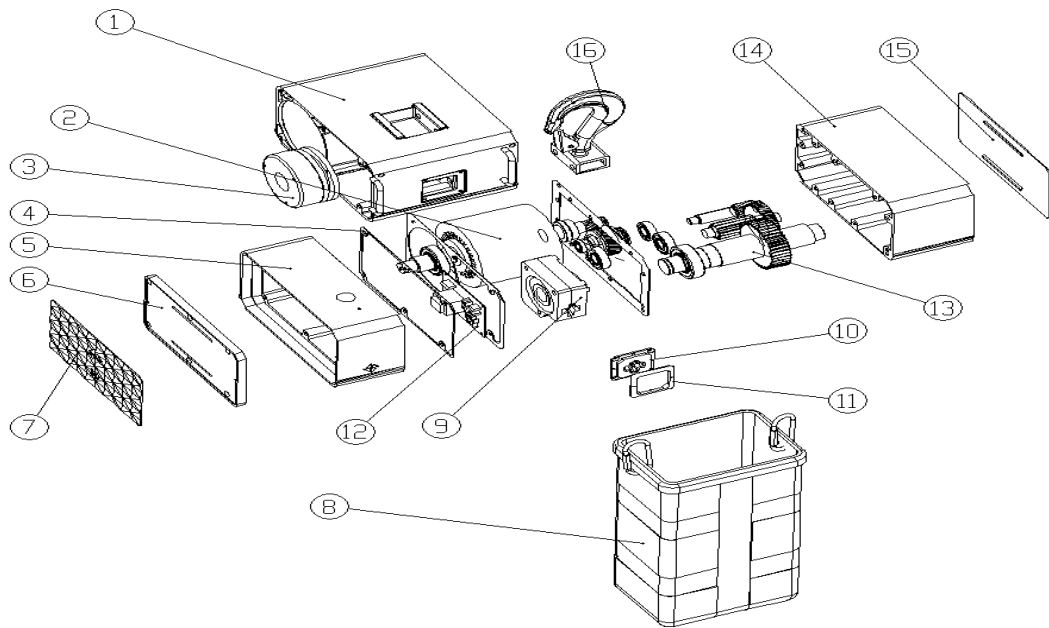

Items	Name	Quantity
1	Gearbox Frame	1
2	Electric Motor	1
3	Brake	1
4	sealant	1
5	Brake side cover	1
6	end cover	1
7	Decorative panels	1
8	Chain Bag	1
9	Chain Orientation	1
10	Chain Exit	1
11	Decorative panels	1
12	PCB	1
13	GEAR	1
14	Gear box cover	1
15	Decorative panels	1
16	Hoist Hook	1

The chain hoists you buy can be only used for lifting a load that doesn't exceed the rated load at maximum.

The service life of chain hoists is dependent upon their suspended weight, average running time, start times and maintenance.

5.3 Operation of Chain Hoists

Transmission Chain

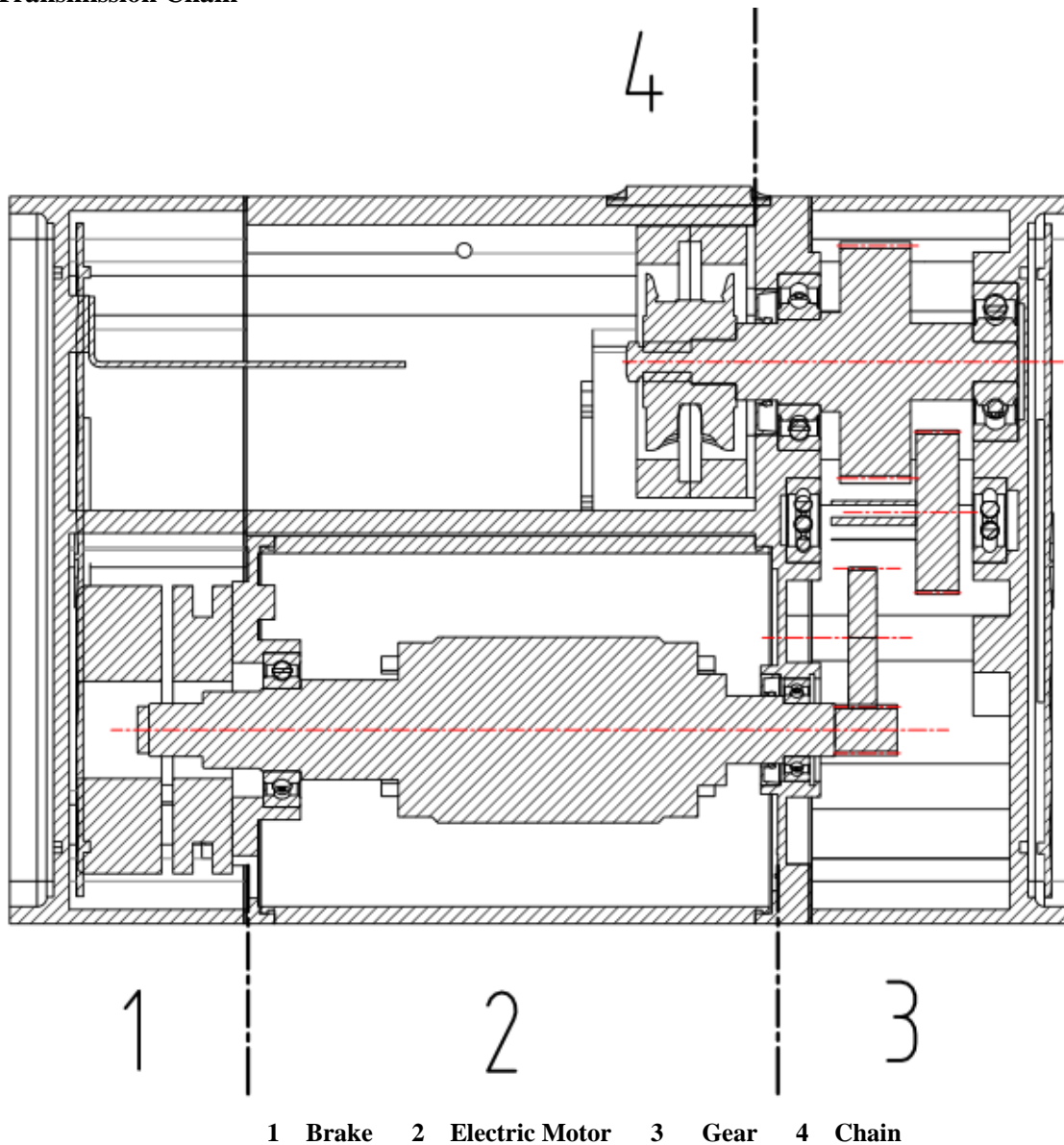

5.4 Dimension and Weight of Chain Hoist

Please refer to the dimensional drawing.

5.5 Connection Accessories of Chain Hoist

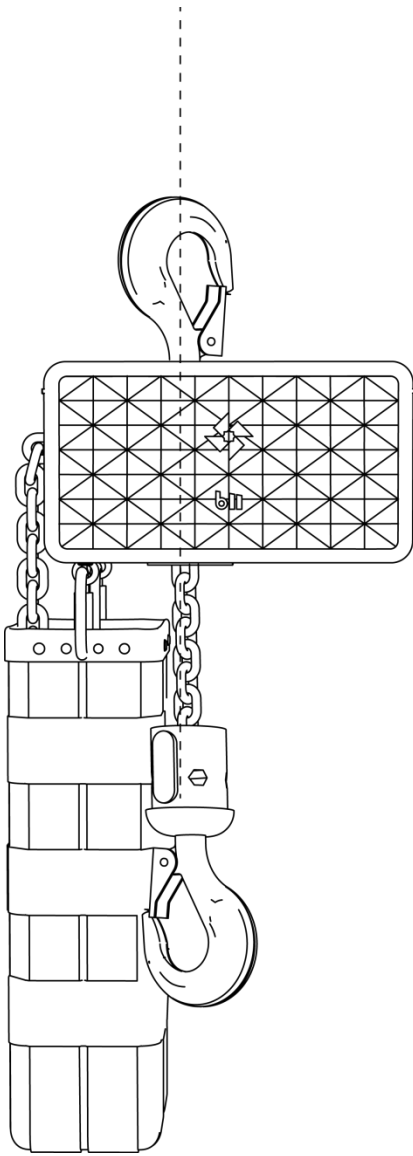

1. Hooks

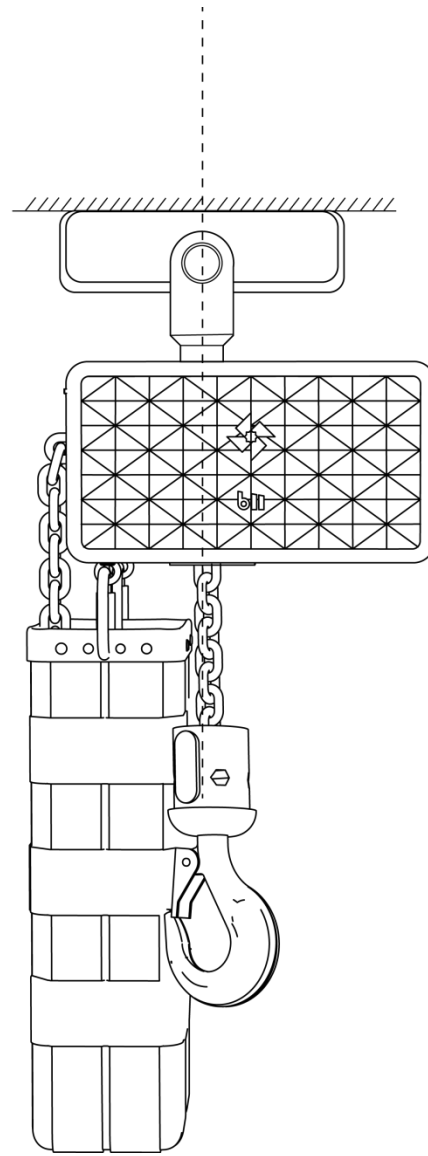

2. Customized Accessories

5.6 Environmental Data

- Ambient temperature: $-20^{\circ}\text{C}\sim+40^{\circ}\text{C}$
- Protection rating: standard IP55
- Side pull angle: $\leq 10^{\circ}$
- Sound level: ≤ 80 decibels

6 Installation

- The service life of chain hoists is dependent upon the installation methods.
- The hoist chains must be installed, used and maintained in strict compliance with this manual.
- All operations against our instructions might be dangerous. The manufacturer will not assume any responsibility for the operations. The lifts must be used after you read and understand this manual completely.
- Put this manual near hoists in places within the reach of operators and maintenance personnel.
- Be sure to follow safety regulations (Clean safety belts/work areas and indicate safety regulations in areas where these regulations must be followed).....

Electric Connections (Applicable to power connections).

Assembly of gear cases (Applicable to gear cases).

- Check whether hooks are installed correctly
- Check tightening torque of the chain guide mechanism; lock up plates and chains with the torque specified in this manual (applicable to tightening torque of screws).
- Check whether chains are distorted.

Once these checks are performed, please operate according to following instructions (be ready to press the emergency stop button any time).

- After lubrication, the chains shall be operated without load for some time.
- During load-free operations, check the movements of hooks along the direction indicated by the arrowhead on the control box.
- Check brake operations: Lift the rated load up and then descent.
- Dynamically test your devices equipped with our chain hoists with +10% of rated load, and statically test them with +25% of rated load.

6.1 Electrical

Confirm whether the power supply of the chain hoist is disconnected before any operation inside the electrical box.

The isolator switch must be installed not 6m away from the chain hoist.

6.1.1 Power connections

- Users must provide power cables, fuses and power isolator switches(refer to wiring diagrams). Check whether the chain hoists use correct power system or not.
- Check and confirm that voltage changes don't exceed+ 5% of the rated value.
- Balanced power.
- Confirm that the power switch of the chain hoist is turned off.
- Don't connect power cables to lifts with terminals (luster terminals). Don't supply power to hoists with rigid cables or those that don't conform to following requirements. Don't go beyond the limits upon isolator switches, power switches or safety equipment.
- Don't block, regulate or disassemble limit stops or switches to make them go beyond allowable upper and lower limits.

6.1.2 Connections

- Take the cover of the control box off.
- Check and confirm whether terminal blocks are screwed up correctly.
- Close the control box.
- Check the minimum cable segment for operating the hoist chain:

Power: 1.50 mm²
Auxiliary current: 0.75 mm²
Control box/chain hoist: 1.00 mm²

Don't change the labels that indicate direction of wires inside the control box or the chain hoist.

6.2 Hoisting Components

- Only use genuine chains produced by manufacturer.
- Don't use hoisting chains as slings.
- Don't twist hoisting chains.
- Don't bundle chains inside the gear case.
- Regularly clean and lubricate chains; check daily whether the chains are in good conditions.

Installation of Integrated Chain Bags

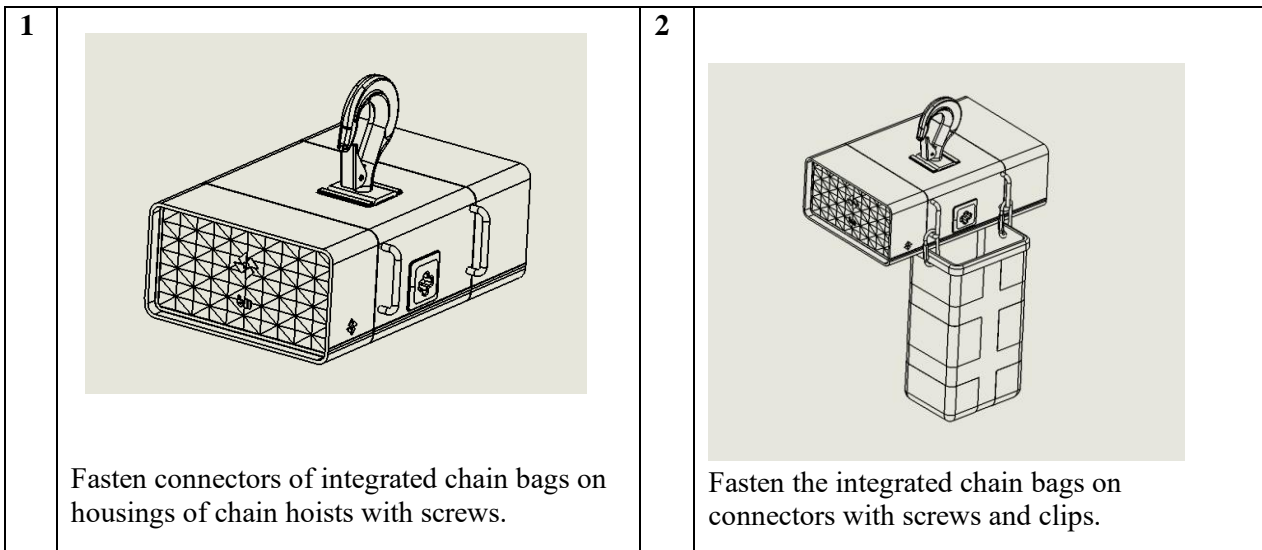

If chain hoists are stored for a long period or transported by ship, please check whether motors are dry. Move chain hoists to the installation positions.

7 Maintenance-Replacement

7.1 Maintenance Form

Test Items	Cycle *	Customers' Eligible Professionals
Inspection of Chain Appearance	Daily	Operator
Chain Cleaning and Lubrication	Monthly	Operator
Measure the degree of wear of chains	Quarterly	Operator
Measure the degree of wear of hooks	Annual	Professional and qualified electrical technician
Lubrication of driven chain wheels	Annual	Operator
Gear lubrication	Lifelong lubrication	

These intervals shall be shortened according to rules of different countries.

If chain hoists are used frequently and often bear the maximum load, or their operating conditions are rigorous, above cycles shall be shortened appropriately.

7.2 Lubrication

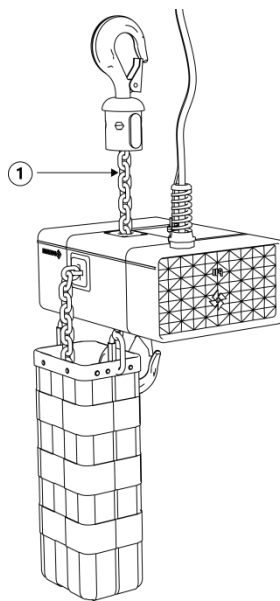

Position	Components	Interval
1	Chains	Lubrication interval shall range from one month to one year dependent upon purposes.

Notes: only designated components are lubricated. Lifelong lubrication shall be performed for other components.

<p>1</p>	<p>Chains</p> <ul style="list-style-type: none"> •To prolong their service life, chains are suggested to be lubricated regularly. •Lubrication interval shall range from one month to one year dependent upon purposes. •The components shall be lubricated before they corrode or become dry. •Lubricate chains with suitable lubricating oil. The chains shall be lubricated with permeable, waterproof and non-viscous grease or lubricating oil. •Over-lubrication might cause oil dripping. <table border="1" data-bbox="233 461 1118 584"> <thead> <tr> <th>Installation</th> <th>Commodity Name</th> <th>Quantity</th> </tr> </thead> <tbody> <tr> <td>Factory Installation</td> <td>Lubricating Oil</td> <td>Dependent upon needs</td> </tr> </tbody> </table>	Installation	Commodity Name	Quantity	Factory Installation	Lubricating Oil	Dependent upon needs	
Installation	Commodity Name	Quantity						
Factory Installation	Lubricating Oil	Dependent upon needs						
<p>2</p>	<p>Gears</p> <p>Lubricate with lubricating oil. Lubricating oil shall be applied in the whole design cycle of chain hoists.</p> <table border="1" data-bbox="233 730 1118 846"> <thead> <tr> <th>Installation</th> <th>Commodity Name</th> <th>Quantity</th> </tr> </thead> <tbody> <tr> <td>Factory Installation</td> <td>Lubricating Oil</td> <td>Free Maintenance</td> </tr> </tbody> </table>	Installation	Commodity Name	Quantity	Factory Installation	Lubricating Oil	Free Maintenance	
Installation	Commodity Name	Quantity						
Factory Installation	Lubricating Oil	Free Maintenance						

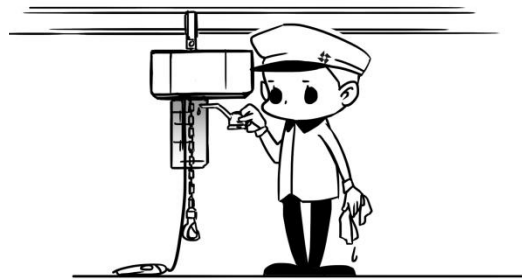

Regular Chain Lubrication

7.3 Chains

Measure the degree of wear on chains

Notes: Regularly check wear, rust and corrosion of chains.

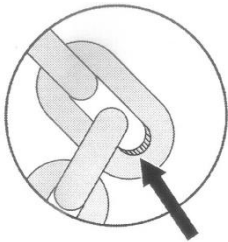
<p>1</p>	<p>Visual Inspection</p> <p>Visually inspect whether chain elements have grooves, scratches, weld spatters, or corrode, twist or get loose. Inspect whether the supporting planes are worn between chain elements.</p> <p>In case of excess pitting, corrosion, scratches, grooves, twist or wear on chain elements, the chains must be replaced by those approved by the factories using such chains.</p>	
----------	---	---

2 Measure thickness of chain elements (d)
 Measure the diameter (d) and dimensions (dm) of chains at several points.
 $dm = (d1 + d2) / 2 \leq 0.9 * dn$
 dn = nominal diameter
 t = pitch
Criterion:

	Chain dimension:		
d*t	4x11	5x14	7x20
dn	4	5	7
P max [mm] (inch)	3.6 (0.142)	4.5 (0.177)	6.3 (0.248)

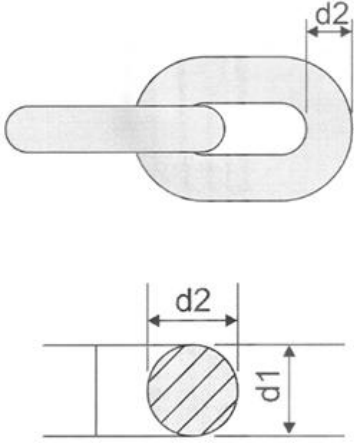

Notes: only use “blade” calipers, in order to eliminate the likelihood of wrong readings resulting from the failure to measure the complete pitch.

Measure the elongation (P)
 Measure the P value on different parts of chains, namely the pitches across 11 chain elements.
 Criteria:

	Chain dimension:		
d*t	4x11	5x14	7x20
dn	4	5	7
P max [mm] (inch)	123.42 (4.859)	157.08 (6.184)	224.4 (8.835)

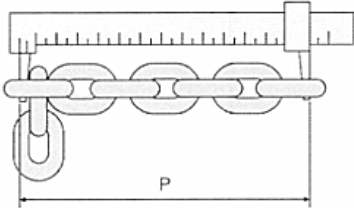

*Notes: According to ISO 7592, the elongation shall be 2%.

Notes: The chains shall be replaced immediately if they go beyond these limits. In this case, it is also necessary to check the wear of chains and sprockets. The chains and sprockets must be replaced when necessary.

Notes: The chain with any defect in any chain link must be replaced.

	Notes	Don't judge any loaded chain to be safe if its measure is below the limit for replacement specified hereunder. Other causes such as those mentioned above in the part of visual inspection might also make chains unsafe and replacement necessary even if the elongation and replacement standards are far from being met.
---	--------------	--

	Notes	Repeated intermittent movements of chains at a point cause serious wear of 2 to 3 chain links on sprockets.
---	--------------	--

Repeated shutdown and start on the same part of a chain cause more serious wear to 2 to 3 chain rings on the timing chain.

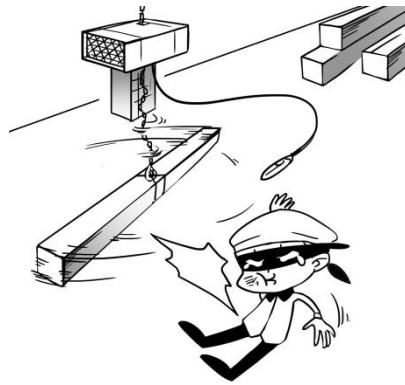

Don't twist hoisting chains.
(Rotate the pulleys with hooks)

7.4 Hooks

Inspect hook openings

Measure hook abrasion

Regularly inspect abrasion of hooks for hanging and hoisting. Damaged safety clamps

Visual Inspection must be replaced immediately.

There must not be evident rust, weld spatter, deep crack or groove on hooks.

Inspect whether chemicals are damaged, deformed, cracked or the unbent hooks are twisted at over 10° from the surface or crack, in order that their hasps can wind around the hook tips.

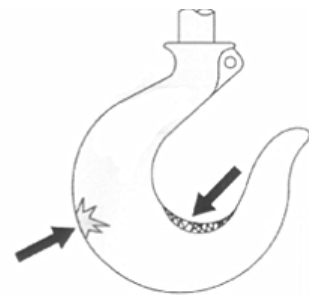

Warnings

If the hook opening is over large, it means the hoist is misused or overloaded. The damages to other bearing components of the hoist must be inspected.

Measure the hoist opening at the bottom (a2)

If the maximum size of the hoist (a2) is larger than the initial size (15%), the hoist must be replaced.

Criterion:

Hoist size	A2 maximum (mm) (inch)
012	25.3 (0.996)
020	28.75 (1.132)
04	34.5 (1.358)
08	41.4 (1.630)

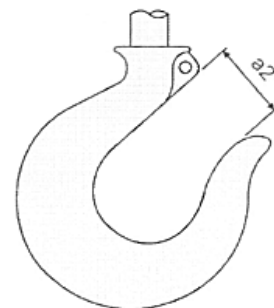

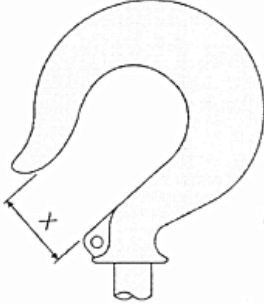
<p>Measure the opening at the top of the hook If the maximum size of the hoist (X) is larger than the initial size (15%), the hoist must be replaced.</p>		
Hoist size	X maximum (mm) (inch)	
012	25.3 (0.996)	
020	28.75 (1.132)	
04	34.5 (1.358)	
08	41.4 (1.630)	

Notes: The hook dimensions are nominal, because they are not controlled in terms of tolerance. In using a brand new hook, reference measurements must be performed on the opening (a2).

7.5 Form on Replacement of Spare Parts

After long-term storage or at the time of annual inspection during after-sales services, please inspect functions and setting of safety devices like brakes. If any component deforms or has any abnormal abrasion, it must be replaced.

Please switch the power off before replacing any accessory.

Spare parts	Replacement Personnel	Users' Qualification
Upper Chain Guide	Manufacturer's Professionals	Electric Technicians with Qualification Certificates
Output Shafts	Manufacturer's Professionals	Electric Technicians with Qualification Certificates
PG Cables	Manufacturer's Professionals	Electric Technicians with Qualification Certificates
Input Shafts for Gears Adjusting Nuts	Manufacturer's Professionals	Electric Technicians with Qualification Certificates
Covers of Electric Motors	Manufacturer's Professionals	Electric Technicians with Qualification Certificates
Transmission Gears (1 st /2 nd Grade)	Manufacturer's Professionals	Electric Technicians with Qualification Certificates
Brake Covers/Cover Seals	Manufacturer's Professionals	Electric Technicians with Qualification Certificates
Other Seals and O-shaped Rings	Manufacturer's Professionals	Electric Technicians with Qualification Certificates
Brake	Manufacturer's Professionals	Electric Technicians with Qualification Certificates
Brake Covers	Manufacturer's Professionals	Electric Technicians with Qualification Certificates
Lower Chain Guide	Manufacturer's Professionals	Electric Technicians with Qualification Certificates
Electrical Boxes	Manufacturer's Professionals	Electric Technicians with Qualification Certificates
Manufacturer's Professionals	Manufacturer's Professionals	Electric Technicians with Qualification Certificates
Bolts	Customers	Technicians with Qualification Certificates
Chains	Customers	Technicians with Qualification Certificates

After any component is replaced, please operate the hoists for inspection.

7.6 Technical Features

Basic technical specifications may be found on nameplates of chain hoists. You can read more extensive technical specifications in this chapter.

Load	1,000 KG
Load Height	25M
Power	3-phase/400V/50HZ
Hoisting Speed	4M/min

Tightening Torque

Recommended tightening torque of steel is shown in the following table.

Descriptions	The numerical values indicated in the table are rated values. In practices like in lubricating bolts, higher torque is needed.
---------------------	---

Bolt Size	Tightening Torque			
	Strength 8.8		Strength 10.9	
	[N·m]	[ft·lb]	[N·m]	[ft·lb]
M4	2.7	2.0	4.0	2.9
M5	5.4	4.0	7.9	5.8
M6	9.3	6.8	14	10.3
M8	23	17.0	33	24
M10	45	33.0	66	48.5
M12	77	56.6	115	84.6
M14	125	92	180	132
M16	190	140	280	206
M18	275	202	390	287
M20	385	283	550	404
M22	530	390	750	552
M24	660	485	950	699
M27	980	721	1,400	1,030
M30	1,350	993	1,900	1,398

Notes: You are suggested to remove all self-locking nuts and install new ones. Self-locking nuts can be used repeatedly for five times at most.

7.7 Hoist Scrapping

- If the service life of a hoist is up to Grade FEM, all components must be inspected by authorized agents or the manufacturer.
- Without the permission of authorized agents or the manufacturer, they must not be further used.
- Before scrapping the machines, please remove all grease and lubricating oil

8 Troubleshooting (3 Phases)

Problems	Causes	Solutions
The chain hoist can't work normally	The emergency stop switch has been activated	The emergency stop switch is disabled
	Trigger the fuse	Replace the fuse
	Activate temperature control (optional)	Allow cooling
	The screws get loose at contactor terminals	Fasten the screws up
	Turn off the main switch	Turn on the main switch
The load can't be increased	Overload	Reduce the load
The braking distance is longer than 10cm	The brake lining is abraded	Replace the brake, and the braking components if necessary
Abnormal noise is generated when the load moves	Chain components are not lubricated	Lubricate components
	Chains are abraded	Replace the chains
	Chain wheels or chain guides are abraded	Replace the chain wheels or chain guides
	The driven chain wheels are abraded	Replace the chain wheels
	Power phases are missing	Inspect the connections of three phases