



FOS RGB DIODE laser series 3000, 4000,
5000 mW



PRODUCT SPECIFICATIONS

TECHNICAL SPECIFICATION

Voltage: 90/250 Volt AC, 50/60 Hz.

Power Consumption: 150 Watt.

Scanner:

- FOS 3000 & 4000: 25kpps High – Speed optical scanner, +/- 20° scanning angle.
- FOS 5000: 40kpps High – Speed optical scanner, +/- 30° scanning angle.

LASER analogue module, 10 kHz:

- FOS 3000 RGB: 400 mW RED (635 nm), 500 mW GREEN (520 nm), 1600 mW BLUE(450 nm)
- FOS 4000 RGB: 600 mW RED (635 nm), 700 mW GREEN (520 nm), 2200 mW BLUE (450 nm)
- FOS 5000 RGB: 1000 mW RED (635 nm), 1000 mW GREEN (520 nm), 3000 mW BLUE (450 nm)

Control: Auto, Music, DMX, ILDA

DMX Channels: 17

SD Card input

Protection Class: IP20 (for indoor use only)

Width: 290 mm

Depth: 230 mm

Height: 310 mm (including the bracket)

Weight: 8,7 Kg

ANIMATION LASER SHOW SYSTEM SAFETY NOTES

Thank you very much for choosing our product, for your safety, please read the laser safety instruction and this manual carefully before your operation.

This manual includes installation and user information.

Please install and operate the laser according to the requirements of this manual and safety guidelines.

DO NOT OVER DRIVE THE SCANNERS. WHEN USING MAX SPEED KEEP THE ANGLE SMALL. FOR MAX ANGLE DO NOT EXCEED 2000PPS ON THE ILDA SOFTWARE SETTING.

CLASS 3b AND 4 LASER USER SAFETY GUIDE

IMPORTANT WARNINGS

Class 4 Lasers have the potential to harm eyesight if looked directly the beam, and in many cases, this may be the case even if viewed over longer distances of several tens of meters. Therefore, before using the laser product you should familiarize yourself with its operation and the safety aspects that need to be considered.

Laser lighting effects are quite safe to watch if installed and used correctly, and being aware of a few basic factors will help you to achieve this. This guide has been prepared to help provide a basic backgrounder to the key safety aspects, and is based on current UK health and safety guidance on the use of lasers for public displays.

Installation

The laser should only be installed and operated by those that are aware of how to operate laser, and what the various controls perform.

The laser should be mounted in a suitable and secure position in the venue, so that once in position it is unlikely to be affected by unintended movement.

Prior to installation and operation of the laser, the paths of the beams and effects should be considered, particularly with respect to how they will touch the audience. If direct audience scanning is desired then the laser energy in the effects needs to be considered to decide if the effects are safe for direct viewing.



NOTE! If the signal cable is over 60 m between the DMX512 controller and fixture or between two fixtures, then a DMX signal amplifier is needed as well.

Introduction

Laser lighting products are used to create some of the most vivid and striking visual effects, and are often noted for how they seem to produce solid shapes that cut through the air, and pick up highly defined swirling smoke patterns. The light that is used to create these stunning effects is different from normal light and therefore several precautions need to be taken when using lasers to ensure that the lighting effects are safe and enjoyable to view. The optical power output from the kind of lasers used for lighting displays can be harmful if not properly setup or is misused. But when used following the recommended health and safety guidelines, laser lighting effects no more harmful than looking at any conventional lighting effect.

Although this guide covers the main points to consider when using laser effects, users are advised to familiarize themselves with other guidance, particularly that issued by the Health and Safety Executive, HS(G)95 The Radiation Safety Of Lasers Used For Display Purposes.

A laser product that emits more than 5mW of light and less than 500mW can be classified as a Class 3B laser product.

A laser product that emits more than 500mW of light and can be classified as a Class 4 laser product.

Class 3B and 4 are safe if used responsibly, and in accordance with the relevant the guidance issued by the Health and Safety Executive.

Class 4 laser devices may cause fires and burn the skin if exposed directly.

In the simplest terms, generally keeping the beams and effects above the audience will not present a hazard to those viewing the show or effects. When you start to aim the laser effects down into the audience area is when it becomes harder to tell if the effects could cause harm. With a Class 3B and 4 laser lighting effect, the problem can arise if the beams or effects hit someone's face. If in doubt, keep the effects above the audience.

Class 3B and 4 laser devices can be harmful to eyesight if viewed directly. i.e. that is, the beam or effect strikes the face of a person directly. The actual injury that a Class 3B and 4 lasers can cause depends upon many factors, including how long the laser beam enters the eye for, the intensity of light, and what part of the eye it gets focused onto. The most susceptible part of the eye to receive damage from a laser is the internal back wall of the eyeball, known as the retina. It is this part of the eye that receives the light signals that are sent to brain. All light entering the eye gets focused onto the retina.

Audience scanning

Audience Scanning is the term commonly used to describe when laser effects are being directly aimed at the viewing audience. This creates a very dramatic looking effect, as people can touch the light, and look down smoky tunnels. But because the laser light can touch or scan past people's faces, it also carries a risk that it could cause damage to people's eyesight, if they are overexposed to the laser light.

The amount of laser light that a person can be exposed to without it causing harm to eyesight is known as the Maximum Permissible Exposure or MPE. These levels are defined in the British Laser Safety Standard BS/EN 60826-1. When people are exposed to laser light which is above the MPE, it poses a risk of causing eye damage. This could be of concern when the laser effects are viewed directly in the face or there is a chance that they could be.

Knowing what the MPE and exposure level is for a given laser effect is quite a complex and involved process to establish. For it is dependent on a whole number of conditions and variables that need to be considered. The laser safety standard BS/EN 60825-1 contains the data required to calculate the safe levels, but it is not straightforward to interpret. Laser Safety Calculation Software has been developed to help ease the task of establishing laser effects exposure.

The BS/EN60825-1 Laser Safety Standard recommends that all establishments that use, or businesses that work with Class 3B laser products, should appoint a Laser Safety Officer (LSO). The Laser Safety Officer should be aware of the safety issues when using lasers, and is responsible for overseeing how the laser is used. In smaller businesses, the LSO will probably also be the installer, operator, owner etc.

The worst-case effect to look at directly is a static single beam, because all the light energy is concentrated into one point.

Menu Screen

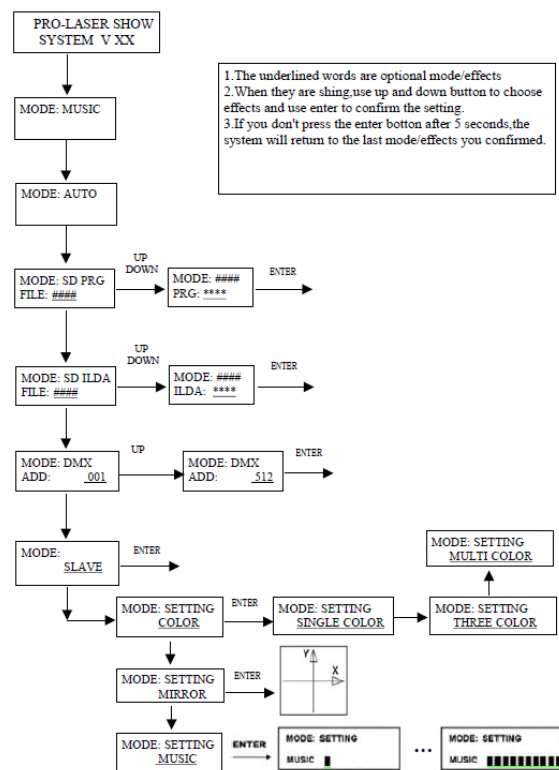

Rear Panel

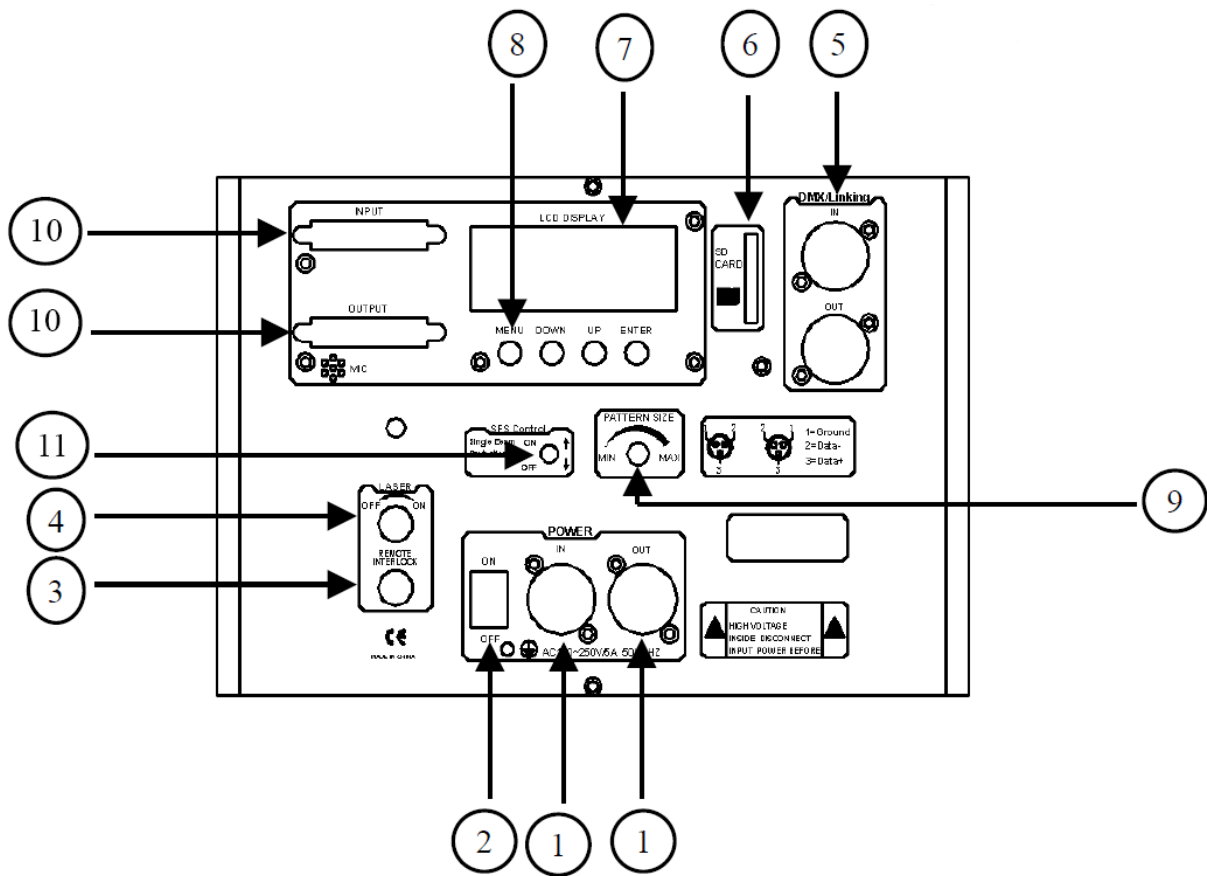

1. Power input / output
2. On / Off switch
3. Remote interlock
4. Safety key switch
5. DMX512 input / output
6. SD-Card socket
7. LCD menu screen
8. Menu navigation buttons
9. Pattern size knob
10. ILDA input / output
11. SFS Control: Scanner fail safety switch On / Off

Note:

1.The underlined words are optional mode/ effects

2. When they are show, use up and down button to choose effects and use enter to confirm the setting.
3. If you don't press the enter button after 5 seconds, the system will return to the last mode/effects you confirmed.
4. ① Press UP/DOWN button to choose PRG FILE, press ENTER button to confirm the file. The default mode is animation effect mode
5. ② Press UP/DOWN button to choose Effects. Press ENTER button to confirm.
6. ③ Press UP/DOWN button to choose FILE. Press ENTER button to confirm the file. The default effects is ANIMATION EFFECT mode.
7. ④ Press UP/DOWN button to choose IILDA program. Press ENTER button to confirm the program.
8. ⑤ Press UP/DOWN button to choose effect mode. Press ENTER button to confirm.

DMX Operation

Channel	Function	Value	Description	
CH1	Model Select	0-9	Laser OFF	
		10-49	PRG mode	
		50-99	ILD mode	
		100-149	Audio(Sound Active) mode	
		150-199	Auto mode	
		200-255	Manual mode	
CH2	Pattern/Folder Select	0-255	Manual mode	PRG/ILD mode
			Pattern select, every 3 value one pattern	File select
CH3	Flashing/File Select	0-10	No strobe	Play file select
		11-199	Auto strobe	
		200-255	Audio strobe	
CH4	RGB Color Selection	0-16	White	
		17-33	Red	
		34-50	Green	
		51-67	Blue	
		68-84	Yellow	
		85-101	Purple	
		102-118	Cyan	
		119-135	White, red, green, blue color section	
		136-152	Blue, yellow, purple, cyan color section	
		153-169	W, R, G, B, Y, P, C 7 color section	
		170-186	White, red, green, blue 4 color flow	

		187-203	Blue, yellow, purple, cyan 4 color flow
		204-220	Blue, yellow, purple, cyan 4 color flow
		221-237	color subsection by inflexion
		238-255	Sound active color change
CH5	X move	0-125	Adjust position by manual
		126-185	Move circle from left to right automatically
		186-225	Jump circle from left to right automatically
		226-245	Auto jumping
		246-255	Audio jumping

CH6	Y move	0-125	Adjust position by manual
		126-185	Move circle from left to right automatically
		186-225	Jump circle from left to right automatically
		226-245	Auto jumping
		246-255	Audio jumping
CH7	Zoom(+/-)	0-10	No change
		11-87	Adjust size by manual
		88-150	Zoom +
		151-200	Zoom -
		201-255	Zoom (+/-) circle
CH8	Rolling X	0	No change
		1-128	Manual rotation
		129-255	Auto rotation
CH9	Rolling Y	0	No change
		1-128	Manual rotation
		129-255	Auto rotation
CH10	Rolling Center	0	No change
		1-128	Manual rotation
		129-192	Auto clockwise rotation
		193-255	Auto counterclockwise rotation
CH11	Drawing	0-10	No change
		10-74	Manual drawing
		75-104	Auto drawing +
		105-144	Auto drawing -
		145-184	Auto drawing circle
		185-224	End to end drawing circle +
		225-255	End to end drawing circle -
CH12	X wave	0-9	No wave
		10-69	Small wave
		70-129	Medium wave

		130-189	Big wave
		190-255	Biggest wave

CH13	Y wave	0-9	No wave
		10-69	Small wave
		70-129	Medium wave
		130-189	Big wave
		190-255	Biggest wave
CH14	Display Mode	0-63	Normal display
		64-127	Light dot display
		128-191	Segment display
		192-255	Dot display
CH15	Red Dimmer	0-255	Dimmer laser output power from 100% to 0%
CH16	Green Dimmer	0-255	Dimmer laser output power from 100% to 0%
CH17	Blue Dimmer	0-255	Dimmer laser output power from 100% to 0%

IR Remote Operation

Button	Function
LASER 	Turn laser ON/OFF
Reset	System reset
Auto	AUTO mode, run built-in auto programs
Music	Sound-active mode, run built-in auto programs
DMX	DMX mode
Slave	Master/Slave mode. The effect same as master mode(AUTO/MUSIC mode)
ILD	Run .ILD files in SD card.
PRG	Run .prg play-list files in SD card.
Floder	Select program floder of .ild and .prg
Muiti.	Multi-effects
Anima.	Animation effects
Grat.	Grating multi-pattern effects
3D-L	3D line effects
3D-P	3D plane effects
3D-R	Row effects
Size	Pattern size adjustment with up and down button
Down	Down adjustment
Up	Up adjustment



General Information

Replacing a fuse:

Always disconnect the fixture from main power before replacing a fuse. Use only the appropriate fuse, with the same type and rating. A fuse with different rating, can damage the fixture in case of failure.

Risk of electric shock and / or fire:

The fixture must be earthed, supplied always with its nominal voltage and cleaned periodically from dust. For cleaning use only, a moist cloth. Never use liquids or force water. After cleaning, let the fixture dry before use.