

TLP Pro 525T

5" TABLETOP TOUCHLINK PRO TOUCHPANEL



The Extron TLP Pro 525T is a 5" tabletop TouchLink® Pro Touchpanel. We designed this first 5" tabletop model with many enhanced features, inside and out. In addition to the new, high-performance quad-core processor and eight times more memory, it also features a high resolution, 800x480 capacitive touchscreen built with scratch and smudge-resistant Corning® Gorilla Glass® and a distinctive enclosure with a sleek, gracefully-sweeping back.

- ▶ 5" capacitive touchscreen with 800x600 resolution and 24-bit color depth
- ▶ Gorilla Glass screen is tough, scratch, and smudge-resistant
- ▶ Faster, quad-core processing and eight times more memory
- ▶ Compatible with all IP Link Pro control processors
- ▶ Power over Ethernet provides power and communication over a single Ethernet cable
- ▶ Built-in speaker provides audible feedback from button presses

DESCRIPTION

The **TLP Pro 525T** is Extron's first 5" tabletop touchpanel. Like the popular 7" and 10" tabletop models in this family, it features a distinctive and beautifully-designed enclosure that complements the decor of any modern workspace. To streamline integration and help minimize cable clutter, the TLP Pro 525T offers the convenience of PoE - Power over Ethernet, which allows it to receive power and communication over a single Ethernet cable.

All TouchLink Pro touchpanels can be customized using Extron GUI Designer software. This powerful interface design software offers ready-to-use templates for a wide variety of rooms and presentation environments. These designs may be used as is, or customized for the application by simply changing individual graphic elements.

KEY FEATURES

- ▶ 5" capacitive touchscreen with 800x600 resolution and 24-bit color depth
- ▶ Gorilla Glass screen is tough, scratch, and smudge-resistant
- ▶ Faster, quad-core processing and eight times more memory
- ▶ Compatible with all IP Link Pro control processors
- ▶ Power over Ethernet provides power and communication over a single Ethernet cable
- ▶ Built-in speaker provides audible feedback from button presses

DIMENSIONAL DRAWINGS

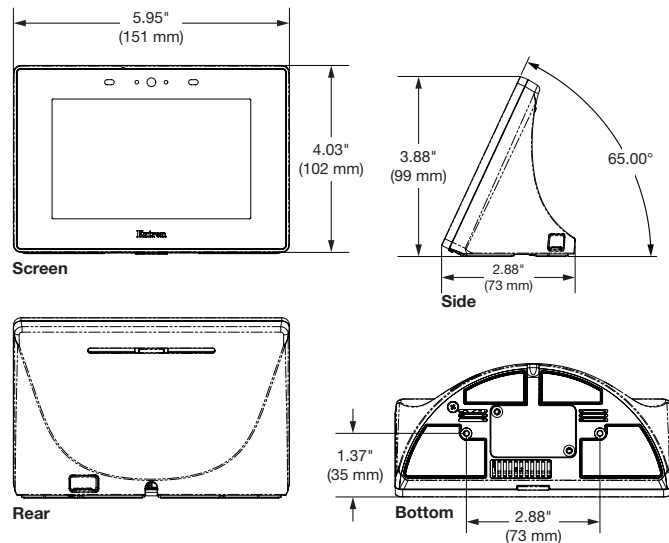

SPECIFICATIONS

DISPLAY		
Screen type	TFT Active matrix color LCD	
Size	5" (12.7 cm), measured diagonally	
Resolution	800x480 (WVGA)	
Aspect ratio	5:3	
Color depth	24 bit, 16.7 million colors	
Contrast	700:1	
STORAGE		
RAM	2 GB	
Storage	4 GB	
ETHERNET		
Data rate	10/100/1000Base-T, half/full duplex with autodetect	
Protocols	DHCP, DNS, HTTP, HTTPS, ICMP, SFTP, SSH, TCP/IP, UDP/IP	
SOFTWARE		
Configuration software	Global Configurator Plus and Professional, GUI Designer	
Programming software	Global Scripter	
Control apps	Extron Control, iGVE	
Resource management software	GlobalViewer Enterprise, iGVE	
Utilities	Toolbelt, Embedded web page	
USB		
Quantity/type	1 high-speed USB 2.0	
Standards	USB 2.0, USB 1.1, USB 1.0 compatible	
AUDIO OUTPUT		
Playback format(s)		
Container format	WAV (Microsoft RIFF)	
Encoding	LPCM (uncompressed)	
Audio channels	Mono or stereo	
GENERAL		
Power input requirements	Power over Ethernet (PoE 802.3af, class 3)	
Auxiliary power output		
USB	5 VDC, 275 mA	
Mounting	Set on a tabletop	
Enclosure dimensions	3.88" H x 5.95" W x 2.88" D (9.9 cm H x 15.1 cm W x 7.3 cm D)	
Regulatory compliance	CE, C-tick, c-UL, FCC Class B, ICES, RoHS, UL, VCCI, WEEE	
Product warranty	3 years parts and labor; touchpanel display and overlay components are covered for 1 year	
Model	Version Description	Part number
TLP Pro 525T	Black - Tabletop	60-1559-02
TLP Pro 525T	White - Tabletop	60-1559-03
TLP Pro 525T NC	Black - Tabletop, NC	60-1559-12
TLP Pro 525T NC	White - Tabletop, NC	60-1559-13

For complete specifications, please go to www.extron.com
Specifications are subject to change without notice.

WORLDWIDE SALES OFFICES

Anaheim • Raleigh • Silicon Valley • Dallas • New York • Washington, DC • Toronto • Mexico City • Paris • London
Frankfurt • Madrid • Stockholm • Amersfoort • Moscow • Dubai • Johannesburg • Tel Aviv • Sydney • Melbourne
Bangalore • Mumbai • New Delhi • Singapore • Seoul • Shanghai • Beijing • Hong Kong • Tokyo

www.extron.com