

# BLAZE

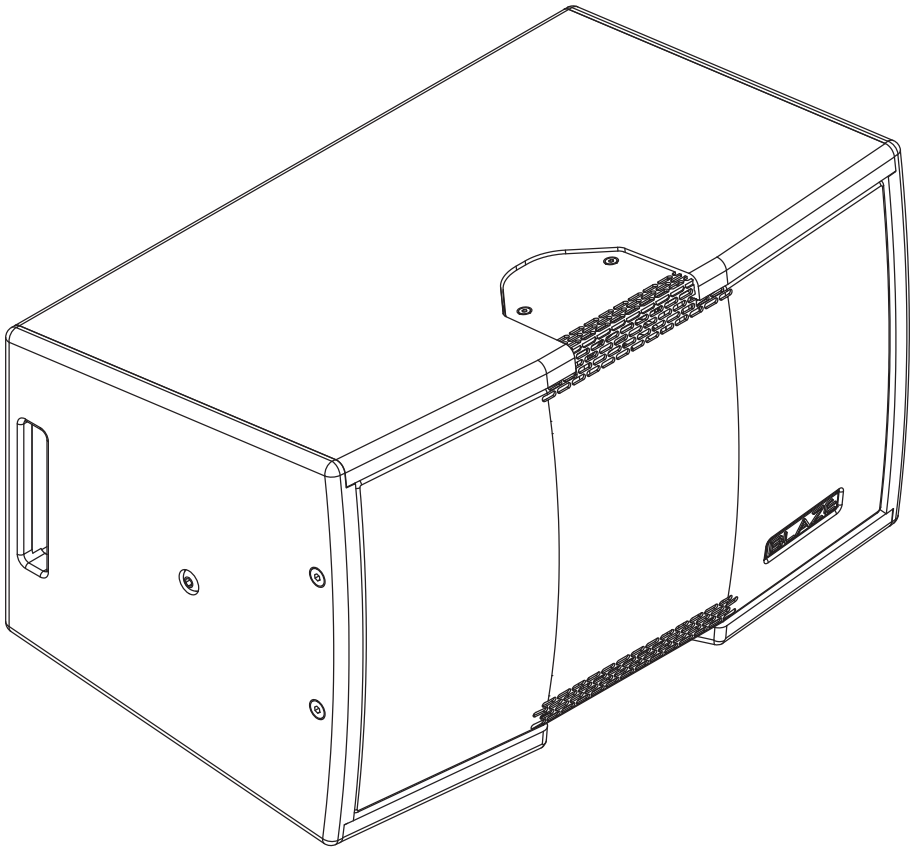

## INSTALLATION MANUAL

CBL523-PAS Loudspeakers

# 1. Introduction and Overview

## 1.1 Introduction

Thank you for purchasing the Blaze Audio CBL523-PAS loudspeaker. The CBL523-PAS is a compact constant directivity, full range loudspeaker designed for installation in venues that require a versatile, short throw, high quality public address loudspeaker solution. Mounted in landscape format, the CBL523-PAS provides 55°\* vertical and 160° horizontal coverage with maximum continuous sound pressure level of 119dB at 1m.

The CBL523-PAS incorporates multiple attachment points that enable a variety of ceiling mount, wall mount and flown installations. A ceiling or wall mount bracket, flying hardware, and coupler straps that enable two loudspeakers to be fastened together in a flyable array are optionally available.

The CBL523-PAS comprises a low frequency array of two high performance 5 inch drivers operating from 71Hz to 520Hz, combined with a vertical line source wide band array of three 2 inch drivers operating from 520Hz to 18kHz. CBL523-PAS loudspeakers are designed to be driven by Blaze PowerZone Connect power amplifiers configured to provide appropriately filtered equalized outputs.

\*Average beamwidth, 500Hz - 5kHz.

## 1.2 CBL523-PAS Pack Contents

Each CBL523-PAS package contains a single loudspeaker and its document pack.

CBL523-PAS  
loudspeaker

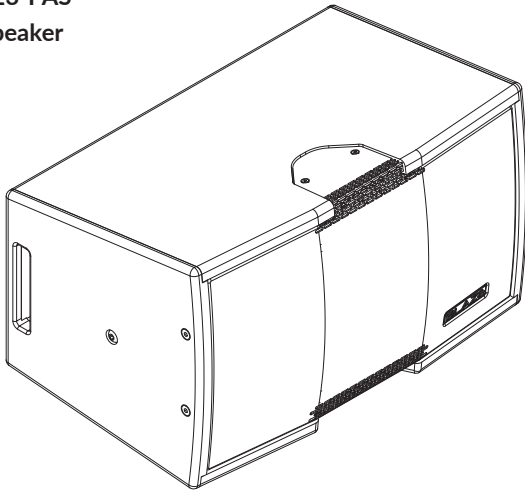

Document Pack

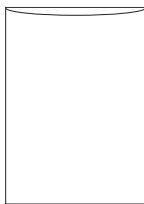

## 1.3 CBL523-PAS Mounting, coupling and flying accessories

The accessories illustrated below are optionally available to enable CBL523-PAS loudspeakers to be wall or ceiling mounted, flown, or coupled in pairs.

CBL523-PAS  
Mounting Bracket

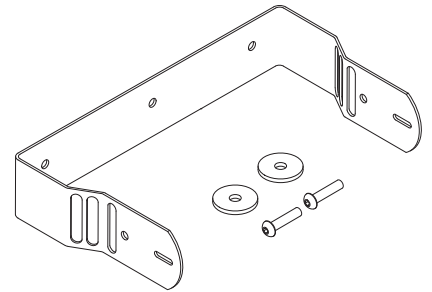

CBL523-PAS  
Flying and Coupling Accessories

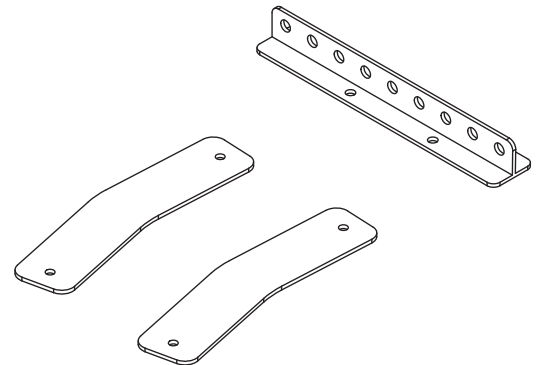

## 2. Applications and Deployment



### 2.1 Important Safety Instructions

**WARNING:** Failure to observe the following safety precautions may result in severe injury or death. Installations such as described in this guide should only be attempted by a trained professional.

- Read these instructions.
  - Keep these instructions.
  - Heed all warnings.
  - Follow all instructions.
  - Before installing or suspending any CBL523-PAS loudspeaker, inspect all hardware, the enclosure, and associated equipment for damage. Missing, corroded, or deformed components, or components without correct load ratings, could significantly reduce the strength of the installation or placement and should immediately be repaired or replaced.
  - Always make sure that the structure the loudspeaker is to be suspended from has been approved by the building or structural engineer and will support the weight of all the components of the speaker system including speakers, speaker cable, wire rope, etc.
  - Consult a licensed professional structural engineer regarding physical equipment installation.
  - Do not suspend loudspeakers directly over people.
  - Use only hardware that is rated for the load conditions of the installation and that allows for a possible short-term, unexpected overload. Never exceed the rating of the hardware or equipment.
  - Blaze Audio strongly recommends that the system be inspected at least once a year and logged. If any sign of weakness or damage is detected, remedial action should be taken immediately.
  - All installation crew members must be trained for loudspeaker rigging and mounting.
  - Make sure that all relevant health and safety regulations are known, are followed by the installation crew, and follow applicable local laws. Local government offices can help with this information.
  - Suspended installations must be completed or supervised by a certified rigger.
  - The system should be designed so that it is a static suspension.
- There should be no dynamic or shock loading.
- Personal protective equipment (hard hats, steel-toed footwear, safety glasses, etc.) should be always worn by the installation crew.
  - If called for in the design, make sure all installation personnel are trained to work at height and have certifications for scissor lifts, theatrical hoists, etc.
  - Make sure all lifting equipment (slings, span-sets, deck chain, scaffolding, etc.) is in good working order. Thoroughly inspect all components prior to use.
  - Inspect all the components associated with the project for damage before assembly. Any parts with damage or suspected damage should not be used. Contact the component manufacturer for replacement parts if necessary.
  - Keep a tidy workplace. Do not leave tools, rigging items, etc., on top of loudspeakers during installation. Loose items can fall and cause injury.
  - Never leave the system unattended during the installation process. Make sure that the workspace is isolated from public access. No one should be allowed to pass beneath the loudspeakers during installation.
  - Do not suspend any other components or loudspeakers other than the supported configurations described in this manual.
  - If secondary steel safeties are required, they should be installed once the entire system is at operating height and before public access is allowed.

## 2. Applications and Deployment

### 2.2 Installation Options

CBL523-PAS loudspeakers can be wall or ceiling mounted, or flown in either singles or pairs. These installation options are illustrated and described in the following sections.

#### 2.2.1 Wall Mount Installation

CBL523-PAS loudspeakers can be wall mounted using the Blaze CBL523 Mounting Bracket. To use the bracket proceed as illustrated and described in the following paragraphs and diagrams.

**Note:** *It is important to ensure that any structure to which a CBL523 loudspeaker is mounted is able to support its weight with an appropriate factor of safety. The fittings and screws used must also be appropriate for the type of building construction. If there is any doubt in either respect, a specialist structural engineer must be consulted.*

**Step 1.** Select the required wall mount location and secure the Mounting Bracket using three appropriate screws and wall fixings. Use flat or pan head screws with a minimum shank diameter of 8mm ( $5/16$  inch) and a minimum head diameter of 12mm ( $1/2$  inch).

**1. Use three screws to secure the Mounting Bracket at the required location.**

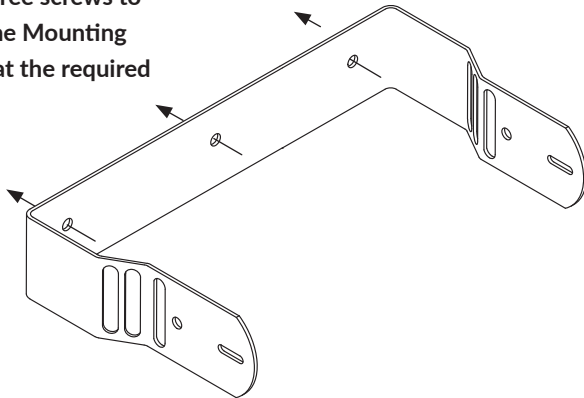

**2. Remove the side panel attachment screws.**

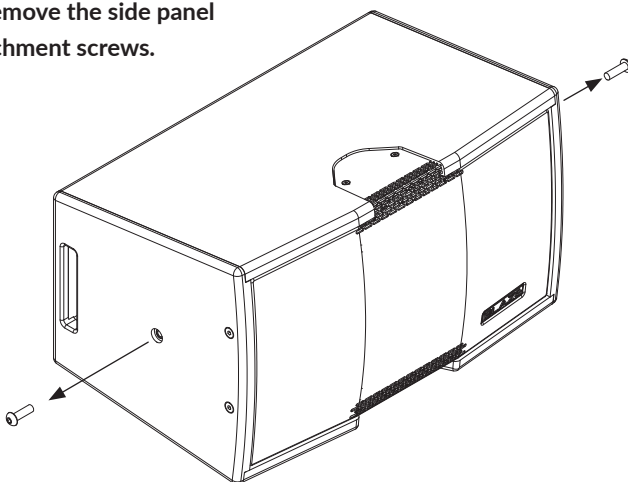

**Step 2.** Remove the attachment point screws located in the loudspeaker side panels.

**Step 3.** Identify the rubber washers in the Mounting Bracket accessory pack. The washers are self adhesive on one side and should be adhered to the sides of the loudspeaker at the screw positions. One washer is required for each side of the loudspeaker.

**Step 4.** Attach the loudspeaker to the Mounting Bracket using the M6x35 screws included in the Mounting Bracket accessory pack inserted through the slot holes in the bracket. Adjust the mounting location in the slot length and the mounting angle as required then tighten the screws so that the rubber washers are compressed to secure the loudspeaker.

**3. Adhere a rubber washer to each side of the loudspeaker.**

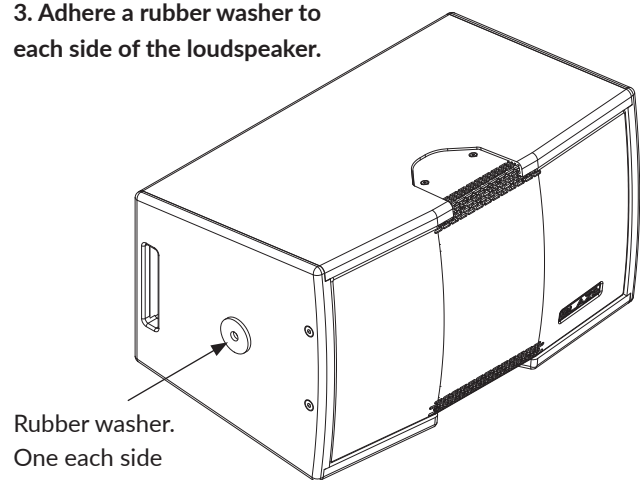

**4. Use the accessory kit screws to secure the loudspeaker to the Mounting Bracket.**

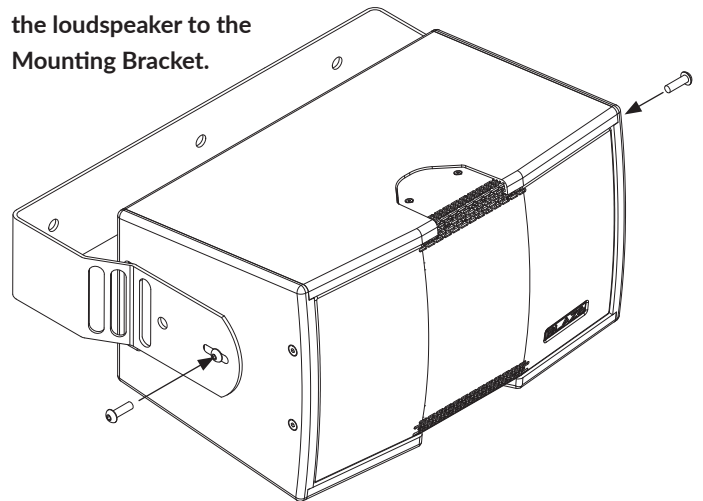

## 2. Applications and Deployment

### 2.2.2 Ceiling Mount Installation

CBL523-PAS loudspeakers can be ceiling mounted using the Blaze CBL523 Mounting Bracket. To use the bracket proceed as illustrated and described in the following paragraphs and diagrams.

**Note:** *It is important to ensure that any structure to which a CBL523 loudspeaker is mounted is able to support its weight with an appropriate factor of safety. The fittings and screws used must also be appropriate for the type of building construction. If there is any doubt in either respect, a specialist structural engineer must be consulted.*

**Step 1.** Select the required ceiling mount location and secure the Mounting Bracket using three appropriate screws and fixings. Use flat or pan head screws with a minimum shank diameter of 8mm ( $\frac{5}{16}$  inch) and a minimum head diameter of 12mm ( $\frac{1}{2}$  inch).

1. Use three screws to secure the Mounting Bracket at the required location.

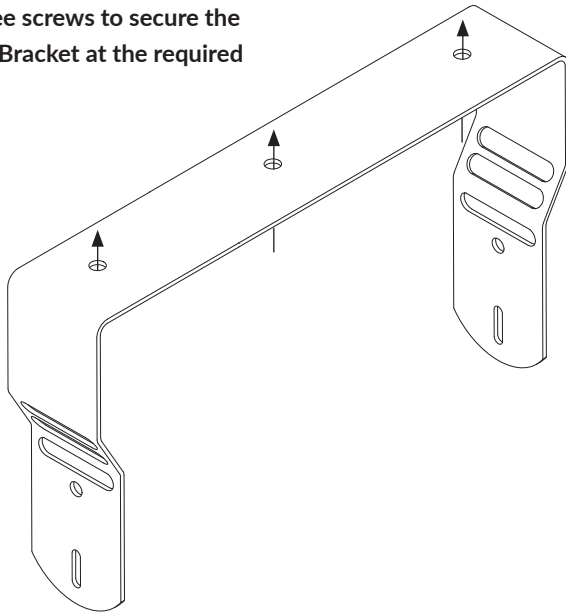

2. Remove the side panel attachment screws.

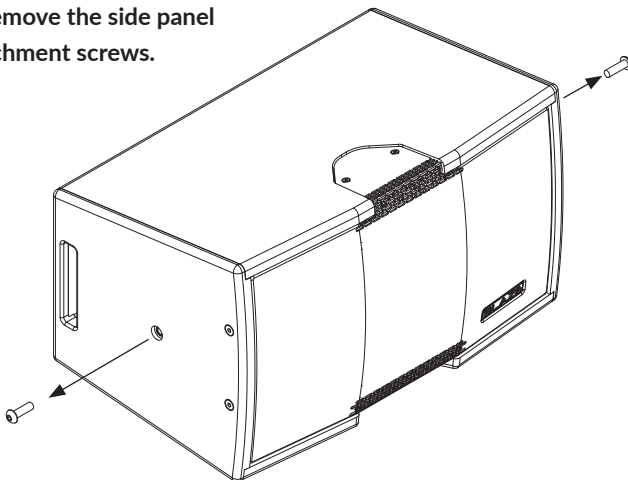

**Step 2.** Remove the attachment point screws located in the loudspeaker side panels.

**Step 3.** Identify the rubber washers in the Mounting Bracket accessory pack. The washers are self adhesive on one side and should be adhered to the sides of the loudspeaker at the screw positions. One washer is required for each side of the loudspeaker.

**Step 4.** Attach the loudspeaker to the Mounting Bracket using the M6x35 screws included in the Mounting Bracket accessory pack inserted through the holes in the bracket. Adjust the mounting angle as required then tighten the screws so that the rubber washers are compressed to secure the loudspeaker.

**Note:** *The Mounting Bracket slot holes are not intended for ceiling mount applications.*

3. Adhere a rubber washer to each side of the loudspeaker.

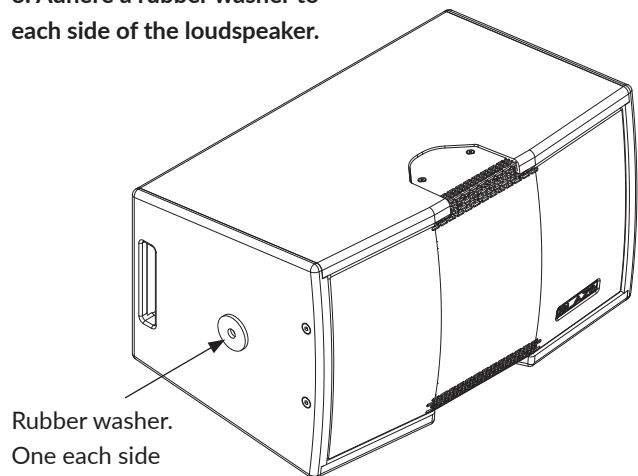

4. Use the accessory kit screws to secure the loudspeaker to the Mounting Bracket.

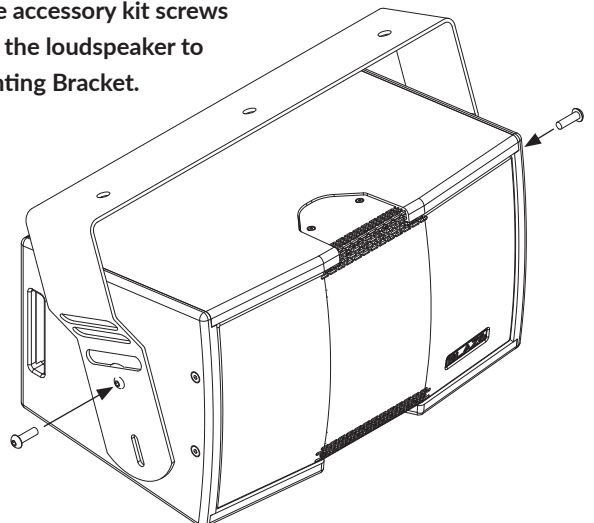

## 2. Applications and Deployment

### 2.2.3 Flown Installation

CBL523-PAS loudspeakers can be flown using the Flying Beam component from the CBL523-PAS Flying and Coupling accessory kit. To attach and use the Flying Beam proceed as illustrated and described in the following paragraphs and diagrams.

**Step 1.** Invert the loudspeaker and remove the four Flying Beam attachment screws. Retain the screws.

**Step 2.** Place the Flying Beam in position on the loudspeaker and

**1. Invert the loudspeaker and remove the four Flying Beam attachment screws.**

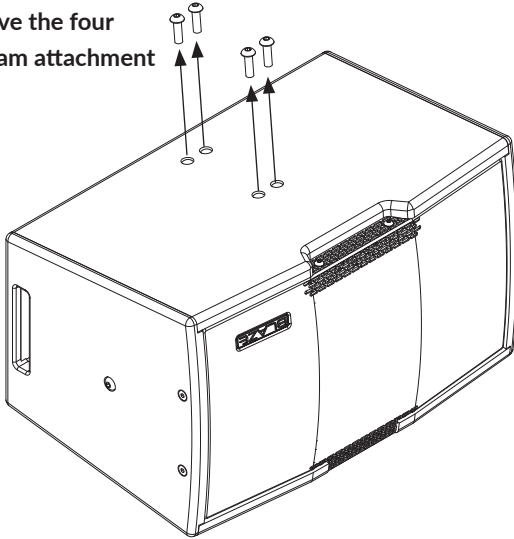

secure it with the screws removed in Step 1. Use all four screws. With the Flying Beam secured, the loudspeaker can be attached to flying hardware. Use at least two attachment holes in the Flying Beam

**2. Place the Flying Beam on the loudspeaker secure it with the screws removed in Step 1.**

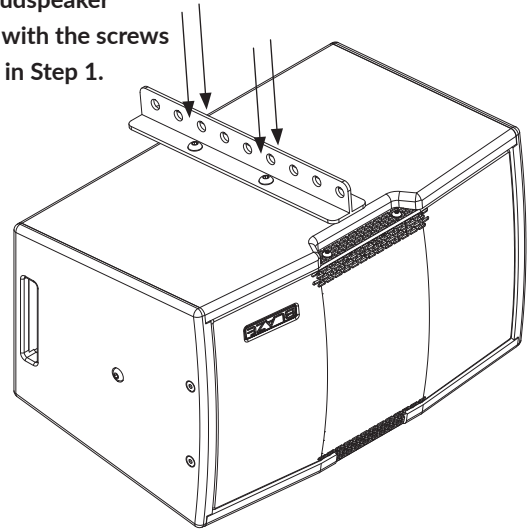

**WARNING:** Consult a professional mechanical or structural engineer, licensed in the jurisdiction of the sound system installation, to review, verify, and approve all attachments to the building or structure. Employ the services of a certified, professional rigger for hoisting, positioning and rigging the equipment to the supporting structure. Improper suspension can lead to serious damage, injury, or death.

**NEVER SUSPEND LOUDSPEAKERS DIRECTLY ABOVE THE AUDIENCE**

## 2. Applications and Deployment

### 2.2.4 Loudspeaker Arrays

Two CBL523-PAS loudspeakers can be coupled together to create a flyable array that offers 30° vertical coverage. To couple two loudspeakers, use the Flying and Coupling accessories and proceed as illustrated and described in the following paragraphs and diagrams.

**Note:** *It is not possible to use the wall or ceiling Mounting Bracket with a coupled loudspeaker array.*

**Step 1.** Attach a Flying Beam, as described in Section 2.2.3, to the (inverted) loudspeaker that is to be the upper element in the array.

**Step 2.** Place the upper loudspeaker with the Flying Beam fitted on top of a second non-inverted loudspeaker and remove the attachment point screws located in the loudspeaker side panels. Retain the screws.

**Step 3.** Use the screws removed in Step 2 to secure a Coupling

**2. Remove the loudspeaker side panel attachment screws.**

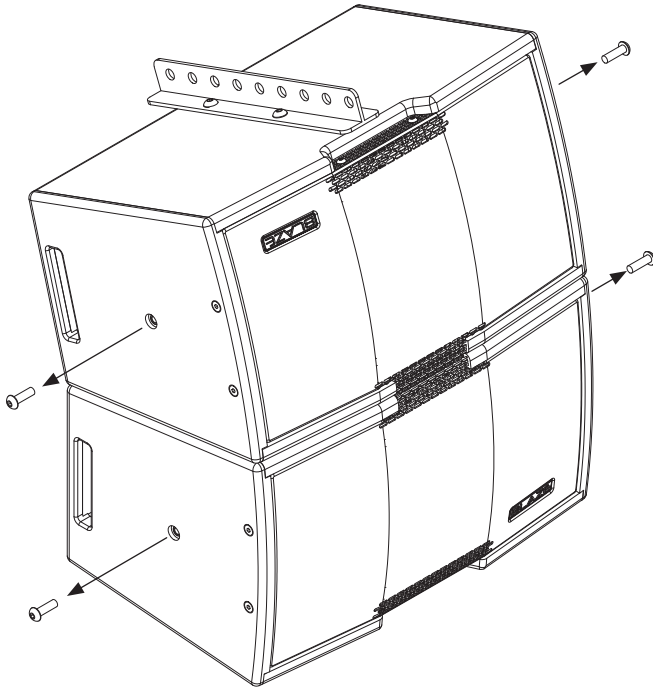

Strap to each side of loudspeaker array. With the loudspeaker array constructed it can be attached to flying hardware. Use at least two attachment holes in the Flying Beam

**3. Secure a Coupling Strap to each side of the loudspeaker.**

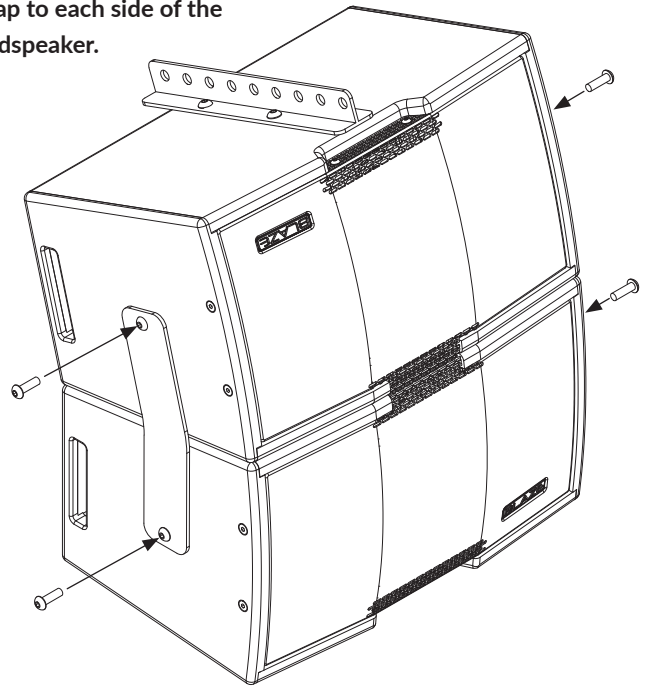

**WARNING:** Consult a professional mechanical or structural engineer, licensed in the jurisdiction of the sound system installation, to review, verify, and approve all attachments to the building or structure. Employ the services of a certified, professional rigger for hoisting, positioning and rigging the equipment to the supporting structure. Improper suspension can lead to serious damage, injury, or death.

**NEVER SUSPEND LOUDSPEAKERS DIRECTLY ABOVE THE AUDIENCE**

# 3. Connection and Amplification

## 3.1 CBL523-PAS Connections

The CBL523-PAS is fitted with a two Neutrik NL4 Speakon sockets on its rear panel for connection to an appropriate Blaze PowerZone Connect Amplifier and optional parallel output connection to a second CBL523-PAS loudspeaker. Input and output connections are described and illustrated below.

### 3.1.1 CBL523-PAS Connections

The CBL523-PAS connection sockets are configured as indicated in the following table and diagrams. The two sockets are wired in parallel to enable the connection of a second CBL523-PAS loudspeaker when, for example, two are coupled in an array as described in Section 2.2.4.

CBL523-PAS Socket Connections	
Signal Routing	Connection Pin
System (-)	1 (-)
System (+)	1 (+)

### Neutrik Speakon NL4 Pins

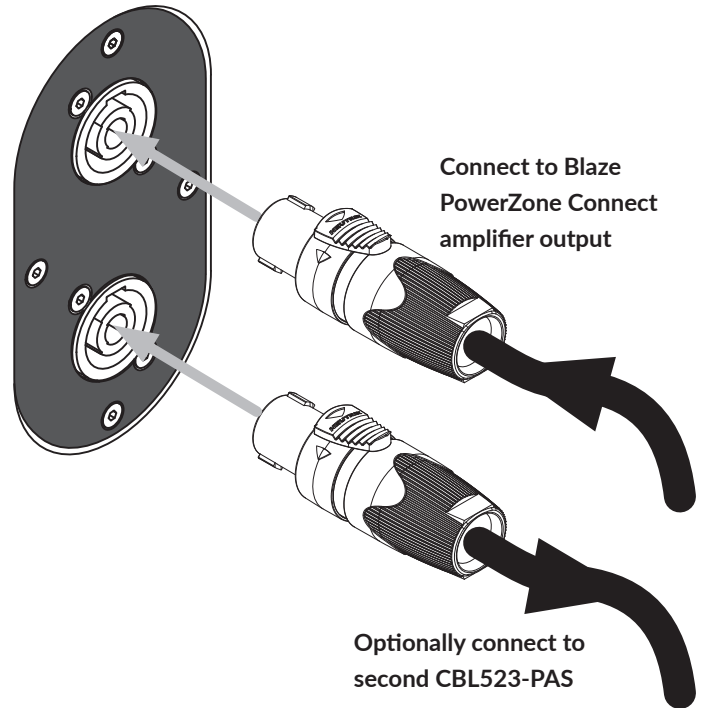
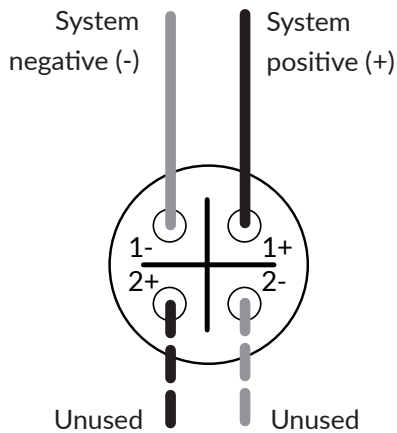



# 3. Connection and Amplification

## 3.1.2 CBL523-PAS Amplifier Connections

CBL523-PAS loudspeakers are intended to be paired with Blaze PowerZone Connect 252 or 504 power amplifiers. These amplifier models incorporate the DSP equalisation facilities required to optimise the CBL523-PAS acoustic performance, while also providing appropriate output power capabilities. The PowerZone Connect 252 and 504 amplifiers are two and four output units respectively.

**Note:** It is possible for each PowerZone Connect amplifier output to drive two CBL523-PAS loudspeakers, however this configuration is not recommend for anything beyond medium duty applications at modest sound pressure levels.

CBL523-PAS loudspeaker and PowerZone amplifier connections are illustrated in the diagram alongside.

**Note:** No more than two CBL523-PAS loudspeakers must be connected to each amplifier channel.

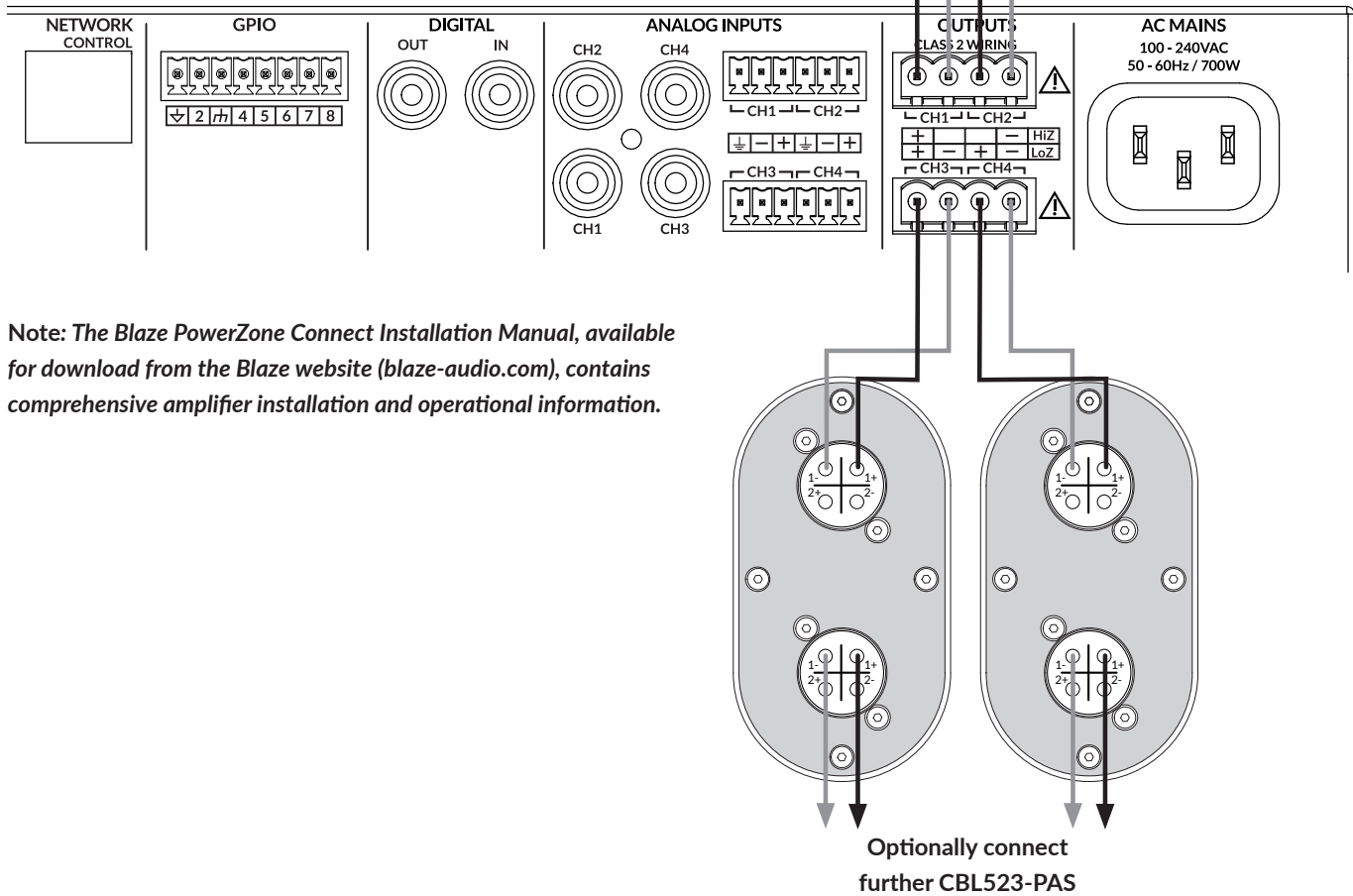

**Note:** The Blaze PowerZone Connect Installation Manual, available for download from the Blaze website ([blaze-audio.com](http://blaze-audio.com)), contains comprehensive amplifier installation and operational information.

# 3. Connection and Amplification

## 3.2 PowerZone Connect Amplifier Equalization Profiles

The Blaze PowerZone Connect amplifier incorporates DSP based loudspeaker equalization, accessed via a web page interface, that enables preconfigured filter and equalization presets to be applied to speaker outputs. A preset for CBL523-PAS loudspeakers is available for download from the Blaze website and must be used for correct loudspeaker performance. The procedure for downloading and applying loudspeaker presets is described in the following paragraphs.

### 3.2.1 PowerZone Control Network Connection

In order to install the CBL523-PAS speaker preset files, the PowerZone Connect amplifier requires either a wired or wireless connection via a TCP/IP network, or to connect via its own wireless access point, to a computer or mobile device from which speaker preset files can be uploaded. Internet access for speaker preset file download is also required.

**Note:** *The PowerZone Connect amplifier Quick Start Guide and Installation Manual documents cover network connection and can be downloaded from the Blaze website: <https://blaze-audio.com/support/#Manuals>*

### 3.2.2 Speaker Preset Download and Application

Follow the steps below to download and apply the CBL523-PAS speaker preset to required amplifier output or outputs.

**Step 1.** Using a computer or mobile device, visit the Blaze website ([blaze-audio.com/products/speakers/ccca10/](http://blaze-audio.com/products/speakers/ccca10/)) and select the speaker preset files for download.

**NOTE:** *The speaker preset files will download in a compressed .zip archive format. Expand the .zip archive and store the files in an appropriate location on the download device.*

**Step 2.** On the computer or mobile device, navigate to the PowerZone Connect 3004 amplifier web interface and select the **Output** tab.

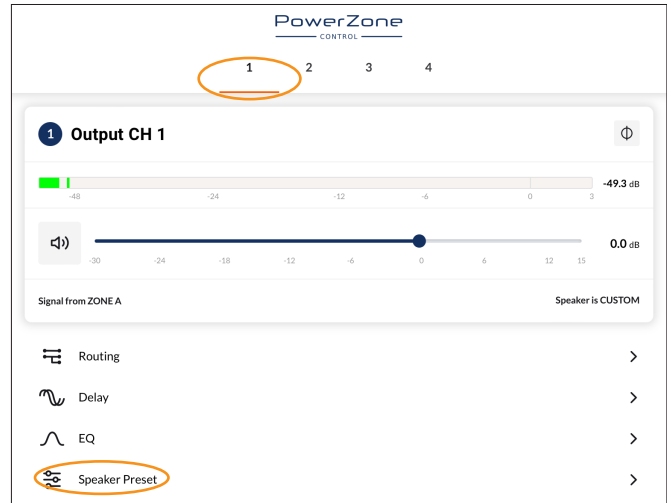

**Step 3.** From the **Output** page select the required **Output** tab at the top of the display and then select the **Speaker Preset** menu option.

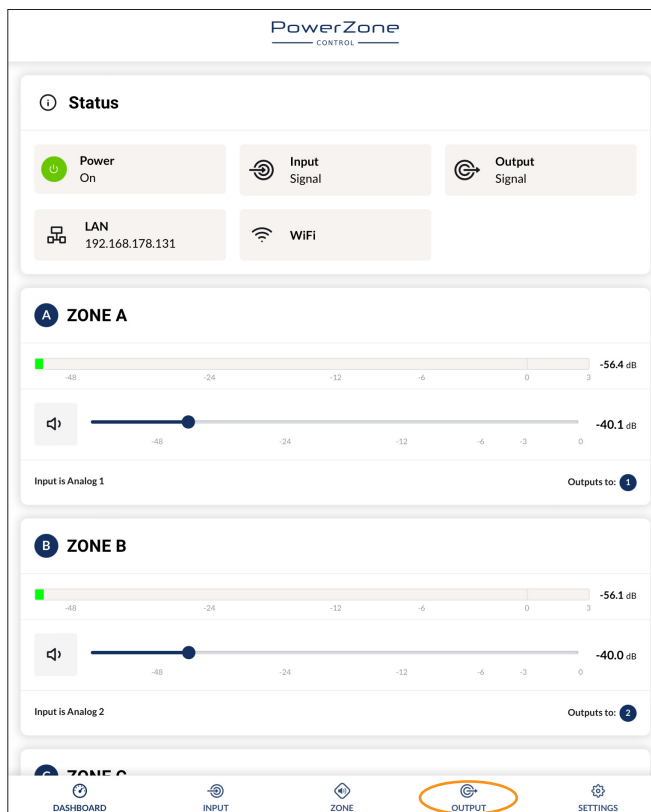

**NOTE:** *The exact appearance and layout of the amplifier web interface may vary slightly depending on the device and browser in use.*

### 3. Connection and Amplification

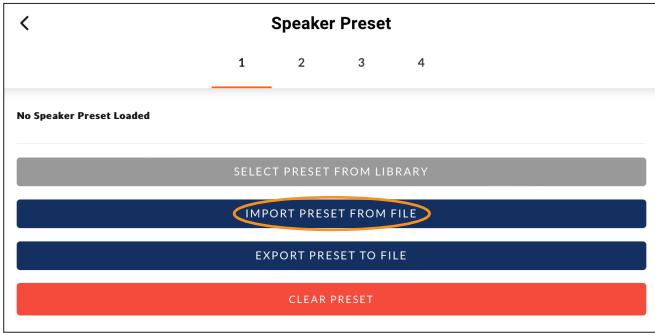

Step 4. Selecting **IMPORT PRESET FROM FILE** will open the **Speaker Preset Import** pop-up box that provides the option to choose a preset file.

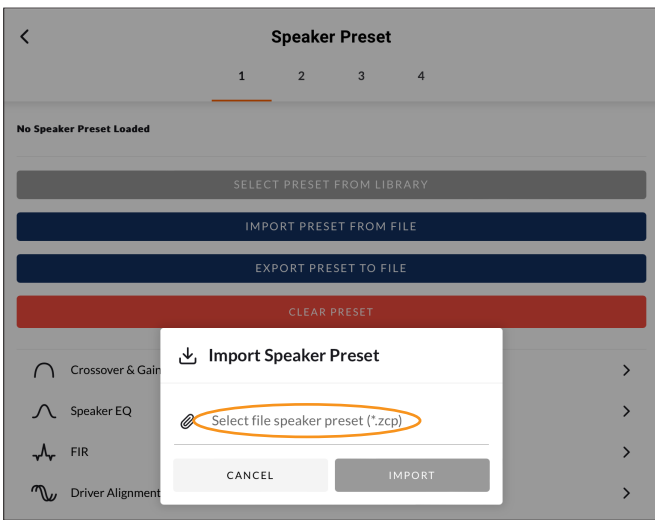

Step 5. Browse the download device for the files downloaded in Step 1 and select the file named: **CBL523-PAS\_PreSet\_Locked\_V1.2.zcp**  
Select **IMPORT**.

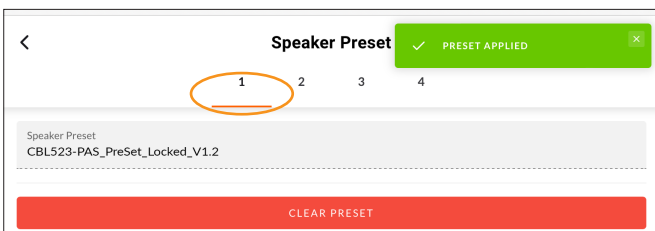
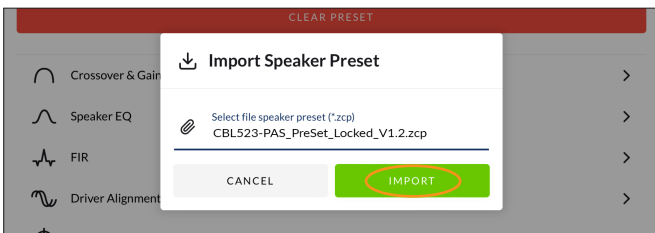

Step 6. The speaker preset file will now be applied to amplifier **Output 1**.

Step 7. With the appropriate speaker preset file (CBL523-PAS\_PreSet\_Locked\_V1.2.zcp) applied to amplifier Output 1, repeat Step 2 to Step 6 for any other amplifier outputs with CBL523-PAS speakers connected.

**NOTE:** Amplifier outputs are selected from the numbered tabs at the top of the amplifier interface Output page.



**IMPORTANT:** It is vital for the correct operation of the CBL523-PAS loudspeaker that the correct speaker preset file is applied to the amplifier output.

## 4. Technical Information

### 4.1 CBL523-PAS Specifications

4.1.1 System Performance	
Frequency Response (-3dB)	71Hz - 18kHz
Frequency Response (-10dB)	55Hz - 18kHz
Recommended High-Pass Filter	48Hz
Horizontal Nominal Dispersion (-6dB)	160°
Vertical Nominal Dispersion (-6dB)	55° (Average beamwidth, 500Hz - 5kHz)
Crossover Frequency	520Hz
Long Term Power Handling (Full Range)	160W
Impedance	4 $\Omega$
Pressure Sensitivity @ 1W/1m (2.83v)	91dB
Max SPL @ 1m	119dB

4.1.2 Physical Characteristics	
Enclosure Material	12mm birch plywood, engineered plastics.
Finish	Two-part spray catalyzed Polyurea coating on plywood.
Grille Material	16-gauge (1.6mm) perforated steel, powder-coated finish, black.
Environmental	Indoor use only.
Connectors/Bi-Amp	Two (2) parallel-wired NL4 Neutrik® Speakon® connectors.
Suspension/Mounting	Wall/Ceiling Mount and Suspension Options. Hardware sold separately.
Dimensions (HxWxD)	8.08" x 13.78" x 8.9" (205.3 x 350 x 226.2 mm)
Net Weight	15lbs / 6.8kg
Shipping Weight	18lbs / 8.16kg

# 4. Technical Information

## 4.2 CBL523-PAS Mechanical Drawings

### 4.2.1 CBL523-PAS Loudspeaker Dimensions

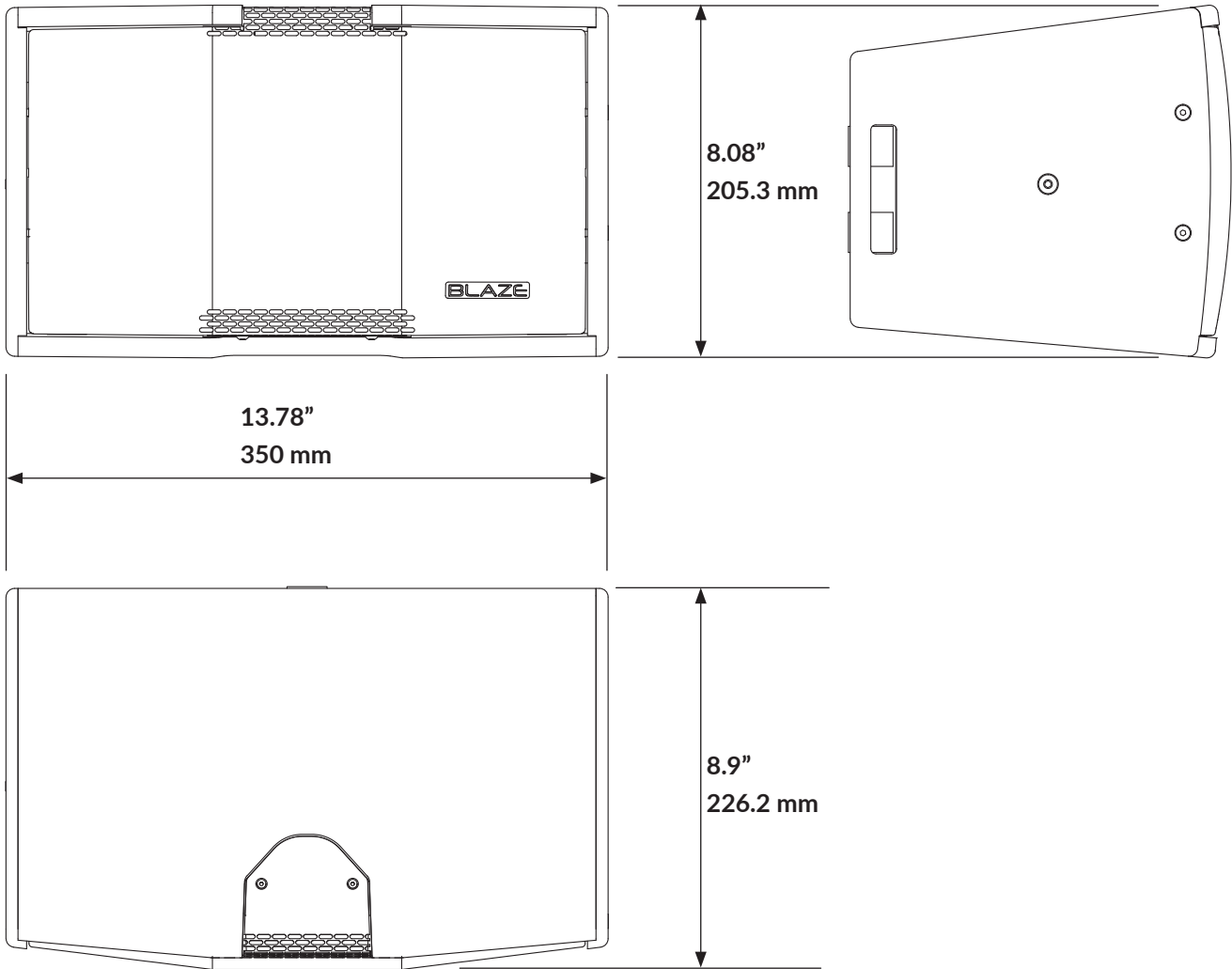

# BLAZE