

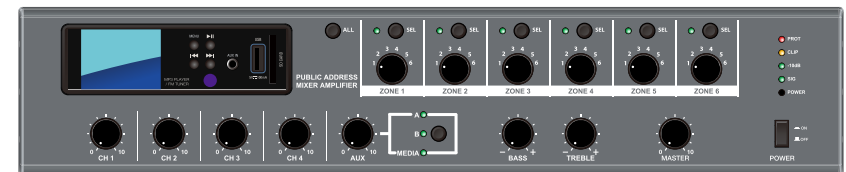

CONSTANT VOLTAGE MIXER-AMPLIFIERS

MODEL : IPA-480



IMPORTANT SAFETY INSTRUCTIONS

1. Read these instructions - All the safety and operating instructions should be read before this product is operated.
2. Keep these instructions - The safety and operating instructions should be retained for future reference.
3. Heed all warnings - All warnings on the appliance and in the operating instructions should be adhered to.
4. Follow all instructions - All operating and use instructions should be followed.
5. Do not use this apparatus near water - The appliance should not be used near water or moisture - for example, in a wet basement or near a swimming pool, and the like.
6. Clean only with dry cloth.
7. Do not block any ventilation openings. Install in accordance with the manufacturer's instructions.
8. Do not install near any heat sources such as radiators, heat registers, stoves, or other apparatus (including amplifiers) that produce heat.
9. Do not defeat the safety purpose of the polarized or grounding plug. A polarized plug has two blades with one wider than the other. A grounding plug has two blades and a third grounding prong. The wide blade or the third prong is provided for your safety. If the provided plug does not fit into your outlet, consult an electrician for replacement of the obsolete outlet.
10. Protect the power cord from being walked on or pinched, particularly at plugs, convenience receptacles, and at the point where they exit from the apparatus.
11. Only use attachments/accessories specified by the manufacturer.
12. Use only with the cart, stand, tripod, bracket, or table specified by the manufacturer, or sold with the apparatus. When a cart is used, use caution when moving the cart/apparatus combination to avoid injury from tip-over. 
13. Unplug the apparatus during lightning storms or when unused for long periods of time.
14. Refer all servicing to qualified service personnel. Servicing is required when the apparatus has been damaged in any way, such as power supply cord or plug is damaged, liquid has been spilled or objects have fallen into the apparatus, the apparatus has been exposed to rain or moisture, does not operate normally, or has been dropped.
15. Please keep the unit in a good ventilation environment.
16. **WARNING:** To reduce the risk of fire or electric shock, do not expose this apparatus to rain or moisture. The apparatus shall not be exposed to dripping or splashing and that no objects filled with liquids, such as vases, shall not be placed on apparatus.
17. **WARNING:** The mains plug or appliance inlet is used as disconnect device, the disconnect device shall remain readily operable.
18. **Power Sources** – This product should be operated only from the type of power source indicated on the rating label. If you are not sure of the type of power supply to your home, consult your product dealer or local power company. For products intended to operate from battery power, or other sources, refer the operating instructions.
19. **Safety Check** – Upon completion of any service or repairs to this product, ask the service technician to perform safety checks to determine that the product is in proper operating condition.
20. Don't touch conductive parts of output terminals to prevent hazardous electrical shock. The external wiring connected to the terminals requires installation by an instructed person or the use of ready-made leads or cords.
21. This equipment is for commercial & professional use only.
22. This product is in compliance with EU WEEE regulations. Disposal of end of life product should not be treated as municipal waste. Please refer to your local regulations for instructions on proper disposal of this product. 
23. To prevent hazardous electrical shock, do not touch the conductive parts of the output terminals. The external wiring connected to the terminals requires installation by an qualified technician or the use of ready made leads or cords.
24. Please locate the apparatus at places nearby power socket for quick power disconnection in emergency.



Protective earthing terminal. The apparatus should be connected to a mains socket outlet with a protective earthing connection.



This lightning flash is intended to alert the user to the presence of non-insulated "dangerous voltage" on the output terminals that may be of sufficient magnitude to constitute a risk of electric shock. The external wiring connected to the terminals requires installation by an instructed person or the use of ready-made leads or cords.



CAUTION
RISK OF ELECTRIC SHOCK
DO NOT OPEN



CAUTION: To reduce the risk of electric shock, do not remove any cover. No user-serviceable parts inside. Refer servicing to qualified service personnel only.



The lightning flash with arrowhead symbol within the equilateral triangle is intended to alert the user to the presence of uninsulated "dangerous voltage" within the product's enclosure that may be of sufficient magnitude to constitute a risk of electric shock.



The exclamation point within the equilateral triangle is intended to alert the user to the presence of important operation and maintenance (servicing) instructions in the literature accompanying this appliance.

CAUTION: To prevent electric shock, do not use this polarized plug with an extension cord, receptacle or other outlet unless the blades can be fully inserted to prevent blade exposure.

Specifications

Performance	
Model Name	IPA-480
Input Sensitivity for full output at maximum gain	
Balanced Microphone Channels	-36dB ± 3dB
Balanced Line Channels	-6 dB ± 3dB
Balanced Remote Microphone Station	0 dB ± 3dB
Balanced EMC	0 dB ± 3dB
Unbalanced Link-Out / Rec-Out	0 dB ± 3dB
Unbalanced Aux-In	-6 dB ± 3dB
Frequency Response	
at 1watt from speaker out tap, 100Hz ~10kHz	+1.5/-3dB
Tone Control	
100Hz, 10KHz	±12dB±3dB
Signal to Noise Ratio at rated power output	Less than 90dB
Crosstalk at all control maximum	-70dB at 1kHz
Rated Output Power at THD 0.5%	480W
Total Harmonic Distortion(THD) at 1kHz rated power	Less than 0.5%
Phantom Power	+48 VDC
Power Band Width at 1kHz from speaker out tap	80Hz~15kHz with less than 0.5% THD
DC Output Offset	Less than ±3mV
Operating Temperature/Humidity at non-condensing	0°~40°C at 95% humidity
Construction	
Cooling	Convection Cooled
Dimensions (Width/Height/Depth)	420 mm X 88 mm X 320 mm
Net Weight	11.2kg

Necessary modifications are carried out without notice.

Table of Contents

Introductions.....	4
Features.....	4
Controls.....	5-6
Setups.....	7-8
Connections.....	9
Operations.....	10-13
Specifications.....	14

Introductions

Welcome

Congratulation and thank you for the purchasing IPA-480 series, a multi-function commercial amplifier.

These amplifiers are designed to provide a big impact in sound reproduction and to produce the best and highest quality audio at an affordable price. We wish you great enjoyment and satisfaction when using your amplifier, whether you are an installation, or reinforcement en gineer.

Unpacking and Installation

Although it is neither complicated to install nor difficult to operate your amplifier, a few minutes of your time is required to read this manual for a properly wired installation and becoming familiar with its features and how to use them. Please take a great care may be needed when moving your set and are required if it ever becomes necessary to return your set for service. Never place the unit near radiator, in front of heating vents, to direct sun light, in excessive humid or dusty location to avoid damages and to guaranty a long reliable use.

Connect your unit with the system components according to the description on the following

Features

The IPA-480 series mixer amplifiers are comprehensive, all-in-one solutions for commercial and industrial applications.

These low-cost units provide all necessary features in a simple building-block format.

- * Four microphone or line inputs with Euro block terminals.
- * Two AUX input with RCA jacks and a media player module.
- * One remote microphone input with RJ45 terminal.
- * Phantom power and VOX control for all of MIC channels.
- * Acceptable wide range input level.
- * User recordable internal voice alarm.
- * Three layer priority muting with EMC (external evacuation message control) input.
- * Built in user selectable pre-announce chime and siren for evacuation.
- * Six zone output with volume control selector.
- * Zone selection and chime control with contact clouser.
- * Advanced protection system includes current limiting, over current and thermal protection.
- * Desktop and 19-inches rack mountable type.

Medioplayer

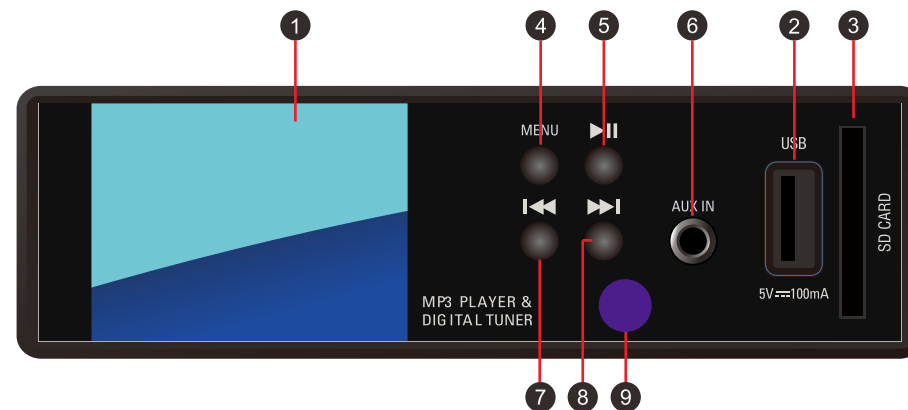

1. Display

2. USB Connector

3. SD Card Slot

4. MENU

Short press to select FM/USB/SD card/Blue Tooth/AUX.

Press and hold to turn on and off of device power.

5.PLAY/PAUSE

Short press to move stored FM frequency for tuner,to toggle play and pause current track for USB,SD card.

Press and hold to search and store audible FM frequency automatically for tuner,stop to play the current track for USB,SD card.

6.AUX IN

External audio signal input jack.

7. 8.PREVIOUS/NEXT

Short press to select previous or next FM frequency for tuner, to select previous or next track for USB,SD card.

Press a nd hold to search previous or next FM frequency automatically for tuner,fast forward or rewind in current track for USB,SD card.

9.IR COMMUNICATION RECEIVER

Remote Microphone Control

IPA-480 series mixer-amplifier can be connected a remote paging microphone station(IPA-Paging Microphone).

The remote microphone station (IPA-Paging Microphone) can select 6 individual zone and play pre- announcement chime.

It should be connected by more than UTP CAT5 cable specification.

This remote microphone station (IPA-Paging Microphone) can be connected upto 4 stations by link port and recommended maximum distance is 200m between IPA-480 series mixer-amplifier and remote microphone station.

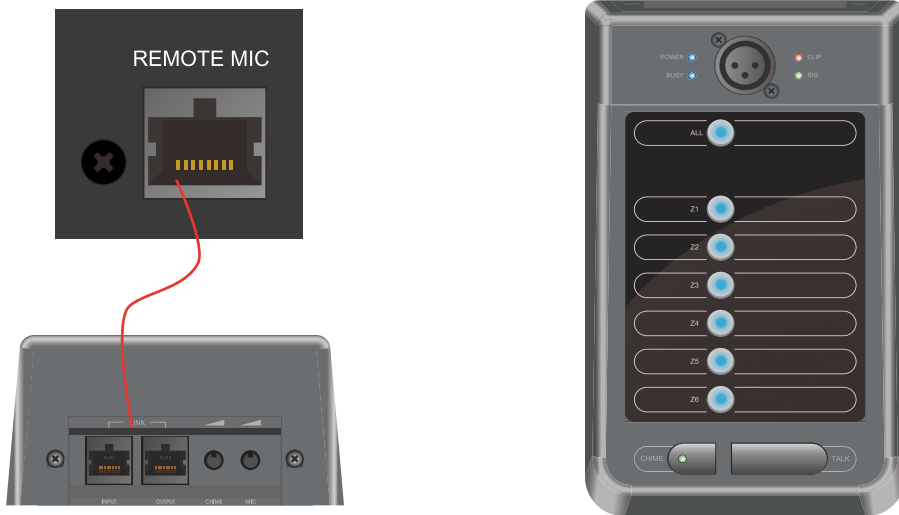

[Figure 3.4]

CAUTION : This port is not network terminal. Do not connect to network device.

Controls

FRONT PANEL

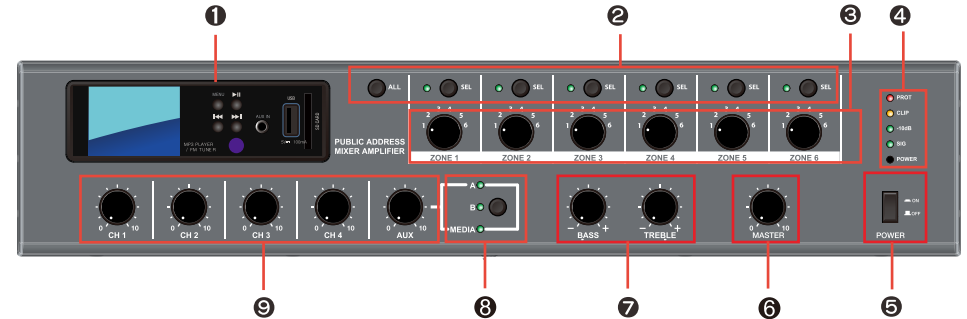

[Figure 1.1 Front panel diagram]

1. Internal music source (MP3 player, FM Tuner and Bluetooth).
2. Speaker zone output selector and indicator.
3. Each zone output level control..
4. Status indicators (Protect/Output level/AC power).
5. Power switch.
6. Master volume control.
7. 2 band tone control(100Hz, 10kHz)
8. AUX and media source selector and indicator.
9. Aux and media source level control
2 band tone control(100Hz, 10kHz)

Rear Panel

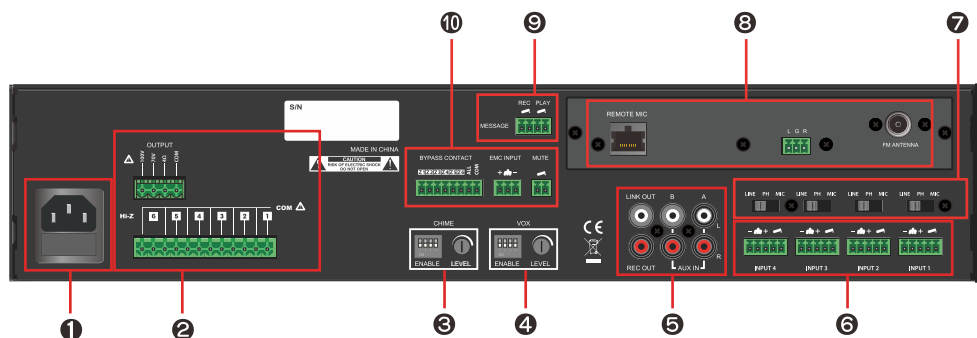

[Figure 1.2 Rear panel diagram]

1. AC 230V 50/60Hz with fuse.
2. Speaker outputs connector (individual zone and 100V, 4-ohm, 70V output).
3. FM antenna, line output of media module and remote mic station(RM6) input jack.
4. VOX enable and level control.
5. Selectable music source inputs (AUX IN A, B) and record output, link output.
6. Balanced Line / Mic input with contact closure for pre-announcement chime.
7. Line / Mic / Mic with phantom power selection for each input.
8. Chime enable and level control.
9. Alarm message recording and playback.
10. External evacuation message input with zone selection and muting other input signals.

User message recording and playback

IPA-480 series mixer-amplifier has internal memory for recording and playback of simple message.

You can recording and playback around 60 seconds message.

This message should be recorded and played by contact clouser on the rear panel.

How to recording . . .

1. Close and hold the PLAY contact input.
2. Close and open the REC contact input for starting recording.
3. Close and open the REC contact input again to stop recording.
4. Open the PLAY contact input for ready to play.

How to playing . . .

1. Close and open the PLAY contact input.

Emergency message input and controls

IPA-480 series mixer-amplifier has emergency message input channel with highest priority.

This message can be played to selected output zones by BYPASS CONTACT on the rear panel.

When evacuation message input through EMC INPUT channel, all other inputs will be muted automatically.

Also MUTE allow to system mute by contact clouser except EMC INPUT.

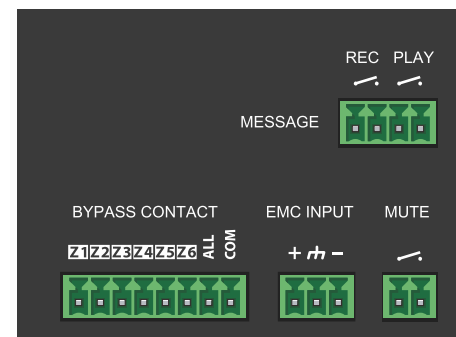

[Figure 3.3]

Operations

Signal input gain control

IPA-480 series mixer-amplifier can accept variable and wide range balanced input signal with gain selection switches.

Phantom power

IPA-480 series mixer-amplifier supply DC +48V phantom power to use condenser microphone with all of MIC channels. The switch should be located PH position.

Chime control

IPA-480 series mixer-amplifier allow to control chime by contact clouser in each input 1~4.

If you want to play chime at input channel 2 then enable switch 2 to on position.

This chime level should be adjustec by LEVEL volume.



[Figure 3.1]

VOXcontrol

IPA-480 series mixer-amplifier allow to control VOX with enable switches in each input 1~4.

This VOX level should be adjusted by LEVEL volume.

If channel 2 is enabled VOX then all of other input signals should be muted or reduced by volume.

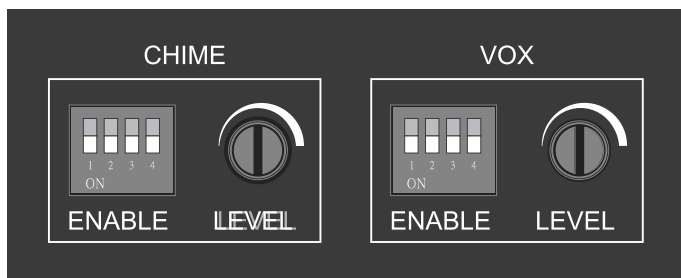

[Figure 3.2]

Priority control

IPA-480 seeries mixer-amplifier has four layer priorities mute function for each inputs.

When higher level source is activated, other input signals are muted except same priority level.

AUX1~2, Media player > VOX > RM-6 > EMC input

Setups

Installation

CAUTION : Before you begin, make sure your mixer-amplifier is disconnected from the power source, with the power switch in the "OFF" position and all level controls turned completely down(counter-clockwise).

You may stack mixer-amplifiers without using a cabinet or you may place a single mixer amplifier on a surface with 12-inches (about 30cm) of air space around the unit for convection cooling. When using an equipment rack, do not mount units directly on top of each other. Allow 2U between units for convection cooling. The side walls of the rack should be a minimum of 2-inches (about 5cm) away from the amplifier sides, and the back of the rack should be a minimum of 4-inches (about 10cm) from the mixer-amplifier rear panel.

How to attach rack ears.

1. Locate the two rack ears and four rack-ear screws supplied.
2. Place a rack-ear flush with the right front of the chassis.
3. Insert a screw into the bottom hole of the rack-ear and chassis. Screw it in.
4. Insert a screw into the top hole of the rack-ear and chassis. Screw it in.
5. Repeat steps 2 to 4 for the left side of the chassis.
6. Remove the four legs from bottom of unit.
7. Please refer to Figure 2.1

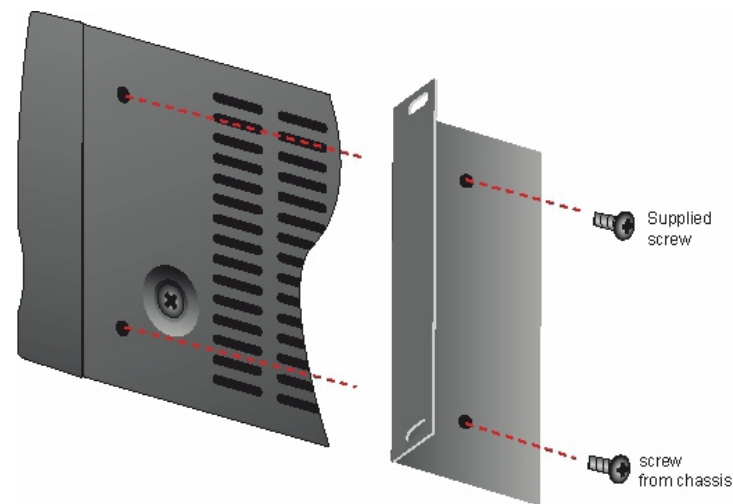

[Figure 2.1 How to connect rack ears]

Wiring guide

Choose input wire and connectors

We recommends using pre-built or professionally wired balanced line. 22 to 24 gauge cables. Figure 2.2 shows connector pin assignments for wiring. The RCA input connections can also be used for unbalanced inputs.

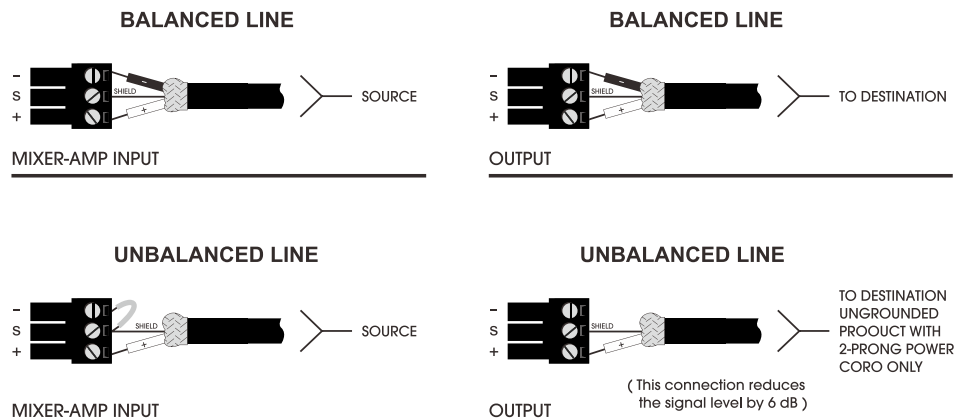

[Figure 2.2 Input wire and connectors]

Choose output wire and connectors

For the amplifier output connectors, We recommends using pre-built or professionally wired, high-quality, and heavy gauge speaker wires. You may use EURO blocks for your output connectors. To prevent the possibility of short-circuits, wrap or otherwise insulate exposed loud speaker cable connectors.

Using the guidelines below, select the appropriate size wire based on the distance from amplifier to speaker. The wire sizes apply to the 4-ohm tap

Distance	Wire Size
Up to 25 ft.	16 AWG
26~40 ft.	14 AWG
41~60 ft.	12AWG
61~100 ft.	10AWG
101ft~150 ft.	8AWG
151~200 ft.	6AWG

NOTE : Custom wiring should only be performed by qualified personnel. Class 2 wiring is required.

Connections

INPUT : Connect microphones or balanced line-level sources to mixer-amplifier balanced inputs. Set Gain volume accordingly. Connect unbalanced line-level signals to RCA input connectors.

OUTPUT : Maintain proper polarity on output connectors.

For each output channel, connect the output EURO block terminals to the loudspeaker loads.

Use terminals marked 4ohm and COM for a 4-ohm loudspeaker load, or use terminals marked 1 to 6 and COM for constant-voltage(100V) speaker loads.

Connect the COM terminal to speaker negative(-) lead; connect one of the other terminals to speaker positive(+) lead.

The impedance and output voltage are same as following Table 2.1

IPA-480	4Ω / 43V	21Ω / 100V
---------	----------	------------

[Table 2.1 Output voltage and impedance]

NOTE : Impedances indicated in the table 2.1 represent the total speaker system impedances.

CAUTION : Never use both the Low-Z(4 ohms) and Hi-Z(100V) terminals at the same time.