



# Master Audio

## Prijzen Exclusief BTW

**Bekafun & EV sound**  
**Klank & Licht**

Bekafun BVBA  
Heilig Hartstraat 23 B-8870 Izegem  
T 051 31 28 03 | F 051 31 82 18  
[www.bekafun.be](http://www.bekafun.be) | [info@bekafun.be](mailto:info@bekafun.be)  
BTW BE 0457.542.763

# POWER AMPLIFIERS

## HD series

NEW DESIGN WITH ADJUSTABLE POWER LIMITERS



The HD series consists of four models with a power output ranging from 230 W/8 Ω per channel, to 4000 W/4 Ω (bridged), all in a 19"/2U format, ideal for long-term fixed installations.

HD Series technology combines Class AB for the smaller models HD800 / HD1200, with Class H for the more powerful units HD2000 / HD3200 / HD4000.

All models are based on our proven High Dynamic Power technology, which means higher dynamic headroom for an outstanding hearing experience.

They incorporate the soft-start circuit with gradual volume increase, clip limiters and special protection features such as temperature control, overcurrent, DC output and anti-short circuit on the outputs.

- High dynamic Class H amplifiers.
- Linear power supply.
- High reliability, best for installation.
- 2 U 19" rack. Soft Start.
- Balanced XLR inputs.
- Speakon and binding post outputs.
- Clip-Limiter.
- Bridge mode/Parallel switch.
- 2 Ω stable. Forced cooling. Protections: DC, Short Circuit, Temperature, Breaker.



Detachable front panel gives access to a limiter threshold adjust. (LIMITER)

		<b>Retail</b>
<b>HD800</b>	2x 400 W/4 Ω - 2x 230 W / 8 Ω - 14 kg	<b>730 €</b>
<b>HD1200</b>	2x 600 W/4 Ω - 2x 350 W / 8 Ω - 15 kg	<b>835 €</b>
<b>HD2000</b>	2x 1000 W/4 Ω - 2x 600 W / 8 Ω - 18 kg	<b>1,045 €</b>
<b>HD3200</b>	2x 1750 W/4 Ω - 2x 1000 W / 8 Ω - 21 kg	<b>1,225 €</b>
<b>HD4000</b> <span style="color: red; font-weight: bold; background-color: white; padding: 2px;">NEW</span>	2x 1100 W/4 Ω - 4000 W / 4 Ω BRIDGE - 21 kg	<b>1,265 €</b>

# Xamp3K

AVAILABLE MARCH 2016

Xamp3K is an amplifier with a dedicated design to drive two-way bi-amplified systems of the Xcellence series. A 2400 W / 4 Ω Class H channel for low frequency plus a 600 W / 4 Ω channel for high frequency offer a flexible, reliable and powerful option for most loudspeakers combinations. Together with the DSP608, it is a perfect match to control your loudspeakers in applications where active solutions cannot be deployed.



Xamp3K

2400 W + 600 W • 4 Ω

Retail

1,250 €

# TPD

AVAILABLE APRIL 2016

2.1 AMPLIFIER • 2000 W • 64-bit DSP

The original TP concept (which stands for TriPhonic), a 3-channel processing amplifier was first released back in 1988 by Amate Audio. Its unique 3-in-1 topology allowed making subwoofer plus satellite installations for small and medium-sized clubs very easy to set up and use, giving exceptional results only comparable with much more complex and expensive systems. One single device united one stereo amplifier for satellites, another channel for subwoofer and the active signal processing to drive the speaker systems. TPD... a step ahead!



Rear view

TPD

1000 W (SUB) + 500+500 W (L + R) • 4 Ω

Retail

1,365 €

# SIGNAL PROCESSING

## DSP

### Digital loudspeaker management systems

Fully configurable by its front panel keypad/ LCD screen or by PC (Windows / MacOS).

For each input/output: 10 parametrical EQ, 2 seconds delay, limiter, crossover and polarity control. 64-bits architecture.



### DSP206

2-in, 6-out, DSP with USB interface  
24-bit, 48 kHz • 110 dB Dynamic Range

**Retail**  
610 €



### DSP608 Ethernet control

High performance DSP with USB & Ethernet interface  
4 analog + 2 digital-in, 8-out  
24-bit, 65 kHz • 118 dB Dynamic Range

**Retail**  
1,000 €

## TYPICAL INSTALLATION

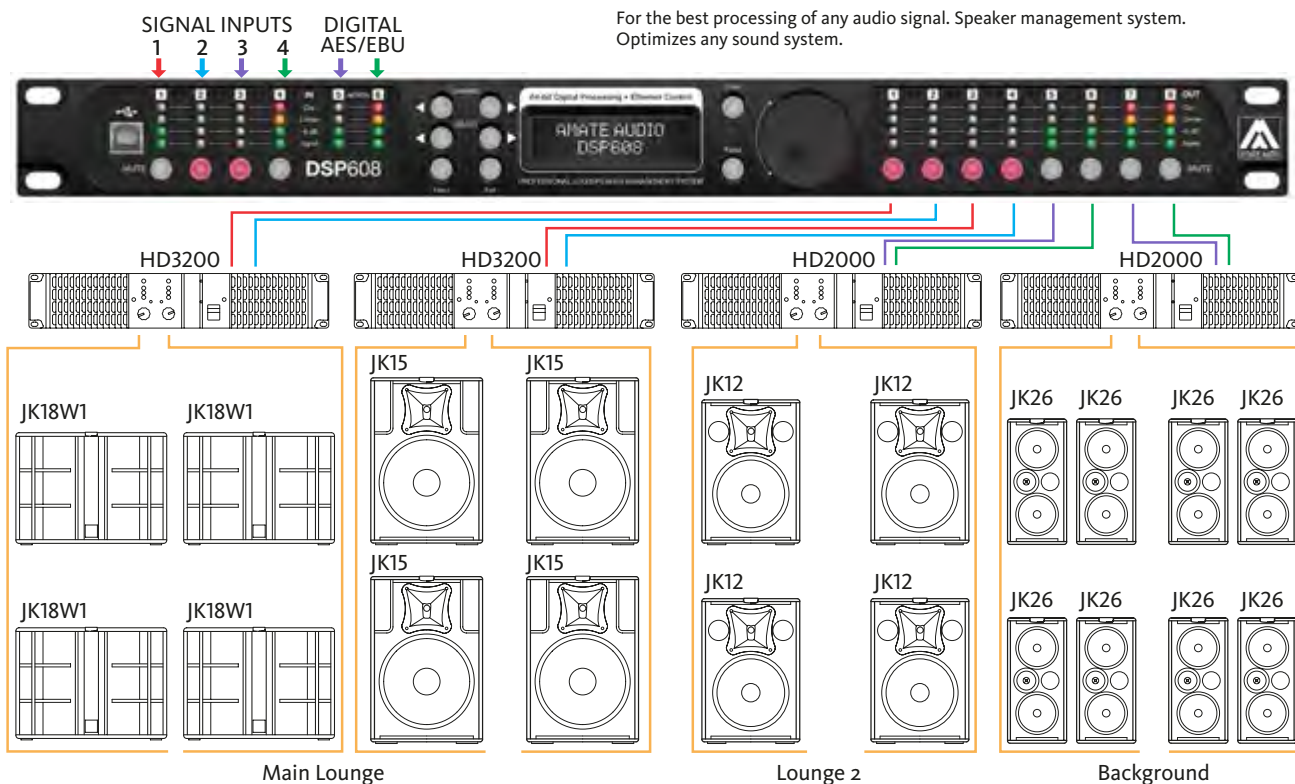

# GE230

## Parametric graphic equalizer

Low noise and compressor-limiter adjustable.



**GE230** LOW NOISE 2x 30 Bands Stereo Graphic Equalizer  
Constant Q • Balanced inputs and outputs XLR  
6/12 dB Range • HPF  
Limiter de salida ajustable en cada canal.

**Retail**  
475 €

# PUBLIC ADDRESS

## CS series

Ceiling systems. Low impedance versions (16  $\Omega$ ) and high impedance for 100 V line.  
High quality transducers for professional sound installations.

**CS6FR** Hi-Fi / High Power 2 way ceiling speaker  
6" Polypropylene cone with butyl rubber surround +  
1" adjustable Titanium tweeter  
30 W rms / 60 W Musical Program – 16  $\Omega$   
Passive filter: 12 dB/Oct.  
Frequency Response: 60 Hz - 20 kHz / 90 dB (1W/1m)  
External diameter: 228 mm  
Weight: 1.5 kg

**Retail**  
55 €



**TF-100** 100 V Line transformer suitable for CS6FR  
(5 W-10 W-20 W-40 W)



25 €

# PUBLIC ADDRESS

## B series

### Multipoint PA Solutions

Compact design, discreet and easy to install.  
Black and white colours.  
High quality transducers for professional sound installations.



		Retail
<b>B5/T</b>	5" Woofer. 1" Titanium dome tweeter Line transformer 100 V (5W/10W/20W/40W) 50 W rms / 16 Ω – 88 dB (1W/1m) Dimensions: 248 x 170 x 145 mm – Weight: 2.9 kg	95 €
<b>B6</b>	6.5" Woofer – 1" Titanium dome tweeter 50 W / 16 Ω – 90 dB / (1W/1m) Dimensions: 310 x 205 x 185 mm – Weight: 4.1 kg	120 €
<b>B6/T</b>	6.5" Woofer – 1" Titanium dome tweeter Line transformer 100 V (5W/10W/20W/40W) 50 W rms / 16 Ω – 90 dB (1W/1m) Dimensions: 310 x 205 x 185 mm – Weight: 4.6 kg	125 €
<b>B8</b>	8" Carbon fiber woofer – 1" Titanium dome tweeter 100 W / 16 Ω – 91 dB / 1W/1m Dimensions: 415 x 270 x 250 mm – Weight: 6.1 kg	170 €

## B5A Multipurpose stereo active system

5.25" Woofer – 1" Titanium tweeter  
Active stereo 30 + 30 W  
Flexible inputs and outputs:  
RCA, mini jack, Terminal block  
Dimensions: 248 x 170 x 176 mm 248 x 170 x 290 mm (with SP-5A)  
Weight: 2.9 + 2.5 kg 3.2 + 2.8 kg (with SP-5A)

**Available colours: arctic white, onyx black and grey titanium.**

*The new B5A means Amate Audio high-end engineering applied to a compact stereo system, just plug and play!  
This active and multipurpose system will fulfill your expectations working both as nearfield monitor or for your presentations...  
And even more, it is compatible with anything, hung on the wall or just standing on your desktop.  
Definitely, B5A is your best multimedia partner.*

### 2 UNITS STEREO SET

Set Retail  
285 €



**SP-5A** (black)  
Wall mount (adjustable bracket)

Retail  
25 €

**NEW** GREY TITANIUM Version



Arctic white version

Onyx black version

# KEY

*Unlock the beat!*



With **KEY**, Amate Audio wants to offer new possibilities and specially help to make a statement: never more your budget will compromise your sound quality!

**KEY** Acoustic Systems are perfect for delivering flawless sound at any venue, offering excellent reliability thanks to their engineering and carefully selected components.

The KEY10, KEY12 and KEY15, full-range systems, can also be used as stage monitors. KEY15W and KEY18W compact subwoofer helps to enhance and complement bass response— all with the absolute reliability of a product **“Made in Spain”**.

**KEY** opens the door to professional sound.  
**KEY**. *Unlock the beat!*

# POINT SOURCE



The KEY point source line is composed of full-range, two-way speaker systems in four formats: 8", 10", 12" and 15".

The combination of multilayer plywood cabinets covered with resistant black matt paint, optimized steel grille, ergonomic handles and carefully selected transducers, allows KEY to have high reliability with an unbeatable price to quality ratio.

PA system or stage monitor, they are the ideal option for both fix and live sound applications on tight budgets.

STAGE  
MONITOR  
POSITION  
KEY10 / KEY12 / KEY15  
KEY12A / KEY15A

		Retail
ACTIVE	<b>KEY12A</b> 600 W Amplifier Class D Bi-amplified DSP with Presets 12" woofer (2" voice coil) – 1" Kevlar diaphragm driver 608 x 420 x 405 mm – 20.1 kg	945 €
	<b>KEY15A</b> 600 W Amplifier Class D Bi-amplified DSP with Presets 15" woofer (2.5" voice coil) – 1" Kevlar diaphragm driver 688 x 474 x 440 mm – 23.2 kg	1,010 €
PASSIVE	<b>KEY8</b> 8" woofer (1.5" voice coil) 1" Neodymium titanium diaphragm tweeter 240 W musical program / 16 Ω – 450 x 295 x 280 mm – 9.5 kg	315 €
	<b>KEY10</b> 10" woofer (2" voice coil) 1" Kevlar diaphragm driver 300 W musical program / 8 Ω – 535 x 365 x 340 mm – 13.5 kg	365 €
	<b>KEY12</b> 12" woofer (2" voice coil) 1" Kevlar diaphragm driver 400 W musical program / 8 Ω – 608 x 420 x 405 mm – 18.7 kg	420 €
	<b>KEY15</b> 15" woofer (2.5" voice coil) 1" Kevlar diaphragm driver 500 W musical program / 8 Ω – 688 x 474 x 440 mm – 21.9 kg	500 €



# SUBWOOFERS

## Compact bass reinforcement

The KEY15W and KEY18W subwoofers are the ideal complement for enhancing bass response at any venue.

Best for a wider acoustic response at lower frequencies. Its helpful ergonomics makes transport easy and its high performance will give a nice tonal balance in any sound system.

KEY15W and KEY18W opens the door to a convincing and accurate low end.

**KEY**  
Unlock the beat!

KEY18WA / KEY18W

KEY15W



ACTIVE

### KEY18WA

1000 W Amplifier Class D  
DSP with Presets  
18" woofer – 4" long excursion voice coil  
700 x 550 x 605 mm – 41.9 kg

Retail

1,255 €

PASSIVE

### KEY15W

15" woofer  
3" long excursion voice coil  
600 W musical program / 8 Ω  
600 x 490 x 520 mm – 27 kg

590 €

### KEY18W

18" woofer  
4" long excursion voice coil  
1000 W musical program / 8 Ω  
700 x 550 x 605 mm – 39.9 kg

705 €

# JOKER

*your best play*



The **JOKER** series is the result of the latest technology engineered, improved and completely customized by Amate Audio with more than 40 years of experience developing acoustic systems.

With a Amate Audio's **JOKER** it is easy to win because it covers the highest demand both in touring and fixed installations.

Its compact design and exclusive characteristics allow setup, cable installation and maintenance easy.

Furthermore, material's strength and quality finishes make your **JOKER** a strong partner for your best play.

**With a JOKER you assure your best play in every situation!**

# POINT SOURCE

**NEW**

WHITE EDITION



JK26 / JK26A+



JK10 / JK10A



JK12 / JK12A



JK15 / JK15A

		Retail
ACTIVE	<b>JK26A+</b> <span style="float: right;"><b>NEW</b></span>	985 €
	450 W Amplifier Class D Bi-amplified DSP with Presets 2x 6" Carbon fiber cone neodymium woofers 1" Titanium diaphragm neodymium tweeter 532 x 250 x 260 mm – 9.5 kg	
	<b>JK10A</b>	1,145 €
	600 W Amplifier Class D Bi-amplified DSP with Presets 10" neodymium Woofer – 1.4" PETP film diaphragm driver 539 x 365 x 340 mm – 14.6 kg	
<b>JK12A</b>	1,410 €	
700 W Amplifier Class D Bi-amplified DSP with Presets 12" woofer – 1.75" PETP film neodymium driver 609 x 410 x 405 mm – 22.7 kg		
<b>JK15A</b>	1,595 €	
700 W Amplifier Class D Bi-amplified DSP with Presets 15" woofer – 1.75" PETP film neodymium driver 689 x 460 x 450 mm – 27.2 kg		

		Retail
PASSIVE	<b>JK26</b>	440 €
	2x 6" Carbon Fiber cone neodymium woofers 1" Titanium diaphragm neodymium tweeter 400 W musical program – 8.7 kg <b>Available in 8 Ω or 16 Ω</b>	
	<b>JK10</b>	560 €
	10" Woofer – 1.4" PETP film diaphragm driver 500 W musical program / 8 Ω – 16.3 kg	
<b>JK12</b>	790 €	
12" Woofer – 1.75" PETP film neodymium driver 700 W musical program / 8 Ω – 21.7 kg		
<b>JK15</b>	935 €	
15" Woofer – 1.75" PETP film neodymium driver 800 W musical program / 8 Ω – 26.2 kg		

# THREE-WAY

THREE WAY SYSTEM

ACTIVE • DSP • 3000 W

JOKER



**JK318A** 3000 W Amplifier Class D – Bi-amplified  
 DSP with Presets  
 18" Neodymium woofer (4" voice coil)  
 12" Neodymium woofer (3" voice coil)  
 1.75" PETP diaphragm Neodymium driver  
 1240 x 534 x 524 mm – 59 kg

**Retail**

3,390 €

# STAGE MONITORS

## VERSATILE COAXIAL ACTIVE SPEAKER SYSTEM



Point source /  
Stage monitor

JK10MA



STAGE MONITOR POSITION

**Retail**

**JK10MA** 700 W Amplifier Class D – Bi-amplified  
DSP with Presets  
10" Coaxial woofer – 2.5" voice coil  
1.75" Polyester diaphragm driver  
539 x 365 x 340 mm – 15.2 kg

1,330 €

## LOW PROFILE STAGE MONITOR



**JK12MA**

700 W Amplifier Class D – Bi-amplified – DSP with Presets  
12" Coaxial woofer – 3" Titanium diaphragm driver  
374 x 600 x 565 mm – 2.4 kg

**Retail**

1,745 €

# COLUMN ARRAY

## ACTIVE FULL-RANGE COLUMN SPEAKER SYSTEM



WHITE EDITION

FRONTAL VIEW

REAR VIEW

## JK46A

600 + 100 W Amplifier Class D Bi-amplified – DSP with Presets  
 Stylized design and low weight ready for everything!  
 4x 6" Neodymium woofers with carbon fiber cone and  
 1.75" wide coverage asymmetrical horn make JK46A a truly multipurpose  
**FULL-RANGE** system with a wide frequency response and great sound quality.  
 1050 x 250 x 260 mm – 19 kg

**Retail**

1,585 €

**ASYMMETRICAL HORN**

Good coverage of audiences often is a conflicting combination of:

- \*wide coverage for the closest audience (short throw)
- \*narrow coverage for distant areas (long throw)

The asymmetrical dispersion horn coverage varies from "short throw" to "long throw" along the vertical axis (keeping a constant vertical directivity).

**Vertical-Positioned JK46A (Flown and aiming to the audience)**  
 We need wide coverage (100°) for the closest listeners and narrow coverage for the distant audience.

Directivity feature of (50° to 100°(H), 55°(V)) can be seen as if the horn itself had "two" horizontal directivities (audience coverage), which depend on the distance.  
 For short distances the horn should be used with its "wide" dispersion (100°).  
 For long distances the horn should be used with its "narrow" dispersion (50°).

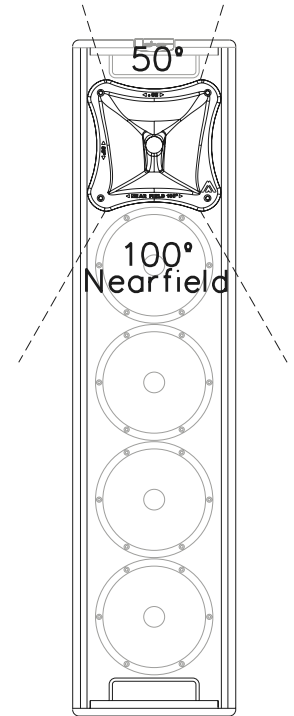
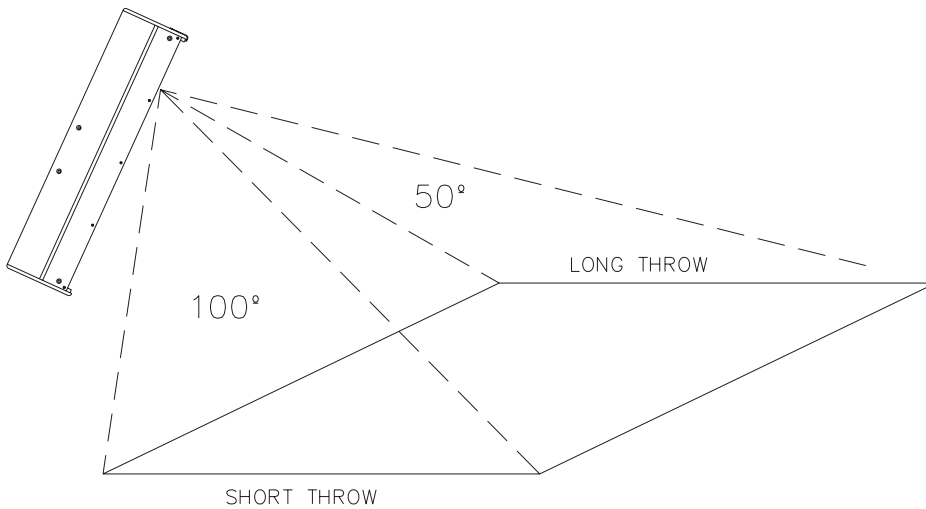





**ACCESSORIES**

**VERTICAL COLUMN-MOUNT**  
 HR-26 + SC-15

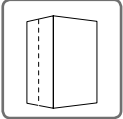
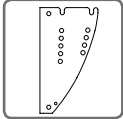
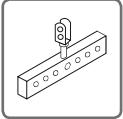
**VERTICAL TRUSS-MOUNT**  
 HR-26 + GT-50HR + SC-15

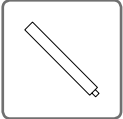
**VERTICAL TRUSS-MOUNT**  
 SP-46

-  NC-JK46
-  SP-46
-  HR-26
-  GT-50HR
-  SP/CR/TL
-  SC-15
-  ACR-M8

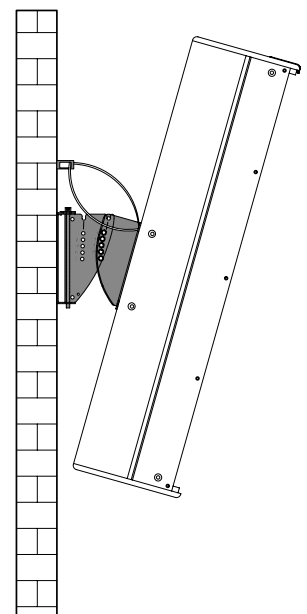
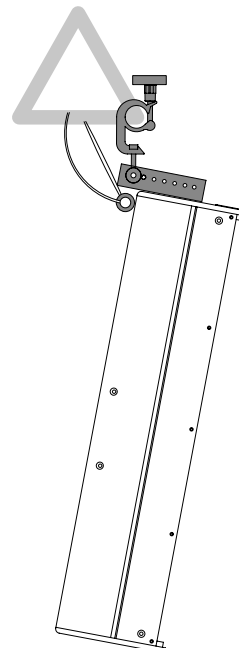
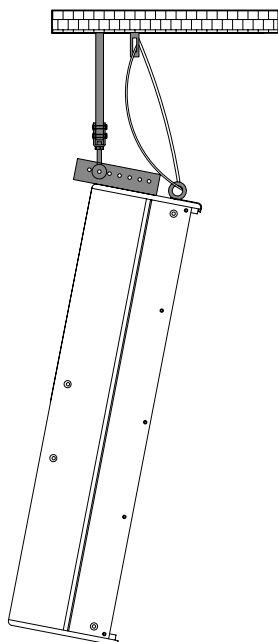

# SUBWOOFERS



JK12WA / JK12W



JK15WA / JK15W

JK18WA1 / JK18WA2  
JK18W1 / JK18W2



## Retail

**JK12WA**

500 W Class D amplifier  
DSP with Presets  
12" Woofer – 3" long excursion voice coil  
387 x 520 x 530 mm – 25.6 kg

1,160 €

**JK15WA**

1000 W Class D amplifier  
DSP with Presets  
15" Woofer – 4" long excursion voice coil  
475 x 630 x 630 mm – 41.6 kg

1,525 €

**JK18WA1**

1000 W Class D amplifier  
DSP with Presets  
18" Woofer – 4" long excursion voice coil  
552 x 740 x 710 mm – 50.9 kg

1,640 €

**JK18WA2**

2000 W Class D amplifier  
DSP with Presets  
18" Woofer – 4" long excursion voice coil  
552 x 740 x 710 mm – 51.9 kg

2,535 €



# Joker



JK218W2 / JK218W4

			<b>Retail</b>
<b>PASSIVE</b>	<b>JK12W</b>	12" Woofer 3" long excursion voice coil 800 W musical program / 8 Ω 387 x 520 x 530 mm – 24.2 kg	665 €
	<b>JK15W</b>	15" Woofer 4" long excursion voice coil 1000 W musical program / 8 Ω 475 x 630 x 630 mm – 39.5 kg	805 €
	<b>JK18W1</b>	18" Woofer 4" long excursion voice coil 1000 W musical program / 8 Ω 552 x 740 x 710 mm – 48.9 kg	970 €
	<b>JK18W2</b>	18" Woofer 4" long excursion voice coil 2000 W musical program / 8 Ω 552 x 740 x 710 mm – 47.8 kg	1,105 €
	<b>JK218W2</b>	2x 18" Woofer 4" long excursion voice coil 2000 W musical program / 4 Ω 572 x 1070 x 805 mm – 77.8 kg	1,475 €
	<b>JK218W4</b>	2x 18" Woofer 4" long excursion voice coil 4000 W musical program / 4 Ω 572 x 1070 x 805 mm – 78.4 kg	1,775 €

# Excellence

## DISCO

- PREMIUM PASSIVE SYSTEMS —
- OUTSTANDING POWER HANDLING —
- LONG-TERM RELIABILITY —
- STATE-OF-THE-ART SPEAKERS —
- UNIQUE DESIGN —



# ready for the club... and beyond!



## READY FOR THE CLUB... AND BEYOND

*Xcellence DISCO* series has been carefully designed to deliver a high sound pressure level while keeping a TOP audio quality. A compact design, but yet with great power handling loudspeakers, makes it suitable for all kind of clubs or other venues requiring high performance passive systems.



## PREMIUM CUSTOMISED COMPONENTS

Each sound system claims to have a personality. For that reason the *Xcellence DISCO* series has been accurately designed including customised components to optimize the acoustic properties of each speaker's cabinet. Speakers, drivers, horns, crossovers, enclosures, lead to a perfect combination that takes full advantage of the technology behind them to create advanced sound systems.



## LONG-TERM RELIABILITY

We have invested in, and applied, the very best knowledge, materials and technology to deliver the ultimate product. Every detail has been considered, featuring the new steel grille with custom punch hole, smart accessories for a trouble-free installation, and the new double-colour Polyurea® paint, not only do they contribute to an extraordinary look, they also look forward high protection and resilience.



## PRECISE ACOUSTIC DESIGN

High-end speaker systems require an accurate acoustic design of the cabinet. Our engineering team uses complex and powerful physical and electroacoustical calculation software to achieve the necessary results in every detail. The cabinet and its components: transducers, drivers, protective grille... everything must perform as a unique element.

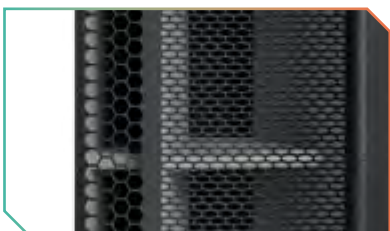

## DESIGN IN EVERY DETAIL

Fixed installations are very demanding and we know it. *Xcellence DISCO* is designed to work for countless hours without interruption. Its loudspeakers, crossovers and materials have gone through the most challenging tests before they have been selected to be in an Xcellence system.



## THE BEST COMBINATION

The best experience of *Xcellence DISCO* system is reached with **Amate Audio's** HD Series amplifiers and DSP2o6/6o8 digital signal processors. Factory presets are available to download and setup the system in a short time.

# POINT SOURCE

## X15D

**Retail**

1,722 €



### FULL-RANGE 15" 2-WAY PASSIVE SPEAKER SYSTEM

*Great coverage and outstanding power handling define this 2-way system that fits every kind of installation. The low frequency and punch of a 15" with a very high definition in the mid-range, topped with a high directivity horn that projects the mid-high with astonishing accuracy. Suitable also for clustering!*

2000 W program power

Nominal impedance: 8 Ω

15" neodymium woofer (4" voice coil)

2.5" titanium diaphragm neodymium driver

Customized 60° x 50° rotatable constant directivity horn

Frequency response: 44 Hz - 19 kHz (with external DSP)

Maximum SPL: 132 dB

Dimensions (HxWxD): 720 x 450 x 460 mm

Weight: 30.5 kg

# SUBWOOFERS

## X18D

**Retail**

1,725 €



### 3200 W 1x 18" PASSIVE SUBWOOFER

*A discreet but powerful subwoofer, the X18D is the ideal choice when there is a limited space available. Obtain a surprising low frequency response in a compact package.*

3200 W program power

Nominal impedance: 4 Ω

18" long excursion heavy duty neodymium woofer (4" voice coil)

Frequency response: 32 Hz - 150 Hz (with external DSP)

Maximum SPL: 134 dB

Dimensions (HxWxD): 540 x 664 x 700 mm

Weight: 40.9 kg

# X218D

## Retail

3,275 €

### 6800 W 2x 18" PASSIVE SUBWOOFER

*A double 18" direct radiation subwoofer with huge power handling to provide with an extensive performance to the low frequency. Power, definition, punch, the X218D has everything to succeed.*

6800 W program power

Nominal impedance: 4 Ω

2x 18" long excursion heavy duty neodymium woofer (4.5" voice coil)

Frequency response: 28 Hz - 150 Hz (with external DSP)

Maximum SPL: 139 dB

Dimensions (HxWxD): 1046 x 740 x 780 mm

Weight: 99.5 kg



# X21D

## Retail

2,565 €

### 3600 W 1x 21" PASSIVE SUBWOOFER

*Experience the ultimate transducer technology in this 21" in a original bandpass/hornloaded configuration. The X21D provides an impressive very low frequency sensation, without compromising the definition of the punch, saving the need of double 15" subs.*

3600 W program power

Nominal impedance: 4 Ω

21" long excursion ultra heavy duty neodymium woofer (5.3" voice coil)

Frequency response: 28 Hz - 140 Hz (with external DSP)

Maximum SPL: 134 dB

Dimensions (HxWxD): 668 x 749 x 900 mm

Weight: 72.9 kg



# SUBWOOFERS

# Xcellence

## TOURING



**Xcellence** is the response of Amate Audio to the challenge of creating high-end products, a compromise to deliver our best and share with you our passion, the search for the best sound.

**Xcellence** means combining the latest available technologies, an extreme care for the finest details and a user friendly design, in order to create a product that meets the most demanding markets and applications with excellent performance.

### ETHERNET CONNECTION & FULL WIRELESS CONTROL



**DSP STUDIO®  
CONTROL  
SOFTWARE**  
iPad App version  
available

# POINT SOURCE

**X14T** **NEW**



**Retail**

2,780 €

**DOUBLE FUNCTION:**  
Main system or stage monitor

**14" COAXIAL ACTIVE SPEAKER SYSTEM**  
**BI-AMPLIFIED 1000 + 500 W, 48 bit - 96 kHz DSP**

*Get the best of two worlds: a revolutionary new 14" coaxial loudspeaker performs as a 15" in the low frequencies, keeping vocals as clear as in a 12". There is no better combination of performance, power, weight and size! An outstanding stage monitor, and still a great deal as main PA. One size fits all: the new X14T!*

Coaxial 14" neodymium woofer (3" voice coil)  
3" titanium diaphragm neodymium driver  
Directivity: 80° Conical

**Ethernet connectivity**

**Built-in DSP – Presets**

Frequency Response: 46 Hz - 20 kHz • Maximum SPL: 128 dB  
Dimensions (HxWxD): 625 x 410 x 430 mm • Weight: 22.6 kg

**X15T** **NEW**

**Retail**

2,945 €

**15" TWO-WAY ACTIVE SPEAKER SYSTEM**  
**BI-AMPLIFIED 1000 + 200 W, 48 bit - 96 kHz DSP**

*The well-known high-end two-way system by Amate Audio, now a step ahead! A new generation amplifier allows a more compact design, but even more powerful and lighter: performance normally found only in larger systems. The 60°x50° constant directivity horn makes it ideal for long coverage and clustering.*

15" Neodymium woofer (4" voice coil)  
2.5" Neodymium titanium diaphragm driver  
Customized 60° x 50° rotatable constant directivity horn

**Ethernet connectivity**

**Built-in DSP – Presets**

Frequency Response: 44 Hz - 19 kHz • Maximum SPL: 131 dB  
Dimensions (HxWxD): 720 x 450 x 460 mm • Weight: 32.9 kg



# SUBWOOFERS

## X18T **NEW**



**Retail**

3,750 €

**18" ACTIVE SUBWOOFER, 2500 W, 48 bit - 96 kHz DSP**

*A new expression of the compact and powerful 18" subwoofer! The new cabinet design with laminar ports gets the most of the latest technology 18" transducer, making this subwoofer an ideal complement to X14T, X15T and X208 line array (stacked or flown).*

18" long excursion neodymium woofer with 4" voice coil

**Ethernet connectivity**

**Built-in DSP – Presets • Cardioid preset included**

Frequency response: 32 Hz - 130 kHz

Maximum SPL: 133 dB

Dimensions (HxWxD): 540 x 664 x 700 mm

Weight: 44.1 kg / 47.5 kg (with KR-18T)



**Retail**

5,095 €

## X215W

**2x 15" ACTIVE SUBWOOFER, 2400 W, 48 bit - 96 kHz DSP**

*Stunning characteristics, both inside and out.*

*The X215W's exclusive Band Pass design provides a surprisingly powerful low-frequency response, balanced perfectly against its size. With two 15-inch woofers, is the best bass reinforcement to be flown with X210. Simply unbeatable!*

2x 15" long excursion neodymium woofers with 4" voice coil and rubber surround.

**Ethernet connectivity**

**Built-in DSP – Presets • Cardioid preset included**

Frequency Response: 32 Hz - 120 Hz

Maximum SPL: 135 dB

Dimensions (HxWxD): 600 x 764 x 859 mm • Weight: 79 kg



**ETHERNET CONNECTION & FULL WIRELESS CONTROL**



**DSP STUDIO® CONTROL SOFTWARE**  
iPad App version available



# SUBWOOFERS



## X218W3K

**Retail**

5,860 €

**2x 18" ACTIVE SUBWOOFER, 3000 W, 48 bit - 96 kHz DSP**

*The combination of two 18-inch woofers with 4.5-inch long excursion voice coil in a highly reinforced cabinet, with 3000 W amplification, DSP and ergonomic design, makes the X218W3K one of the most advanced, powerful and easy-to-handle subwoofer on the market.*

2x 18" long excursion neodymium woofers with 4.5" voice coil

**Ethernet connectivity**

**Built-in DSP – Presets • Cardioid preset included**

Frequency Response: 28 Hz - 120 Hz

Maximum SPL: 138 dB

Dimensions (HxWxD): 1046 x 740 x 780 mm



## X21T **NEW**



**Retail**

4,575 €

**21" ACTIVE SUBWOOFER, 2500 W, 48 bit - 96 kHz DSP**

*The definitive answer to your bass requirements. When it comes to astonish the audience with a superb bass, the X21T will do the work. Thanks to its original design in bandpass/hornloaded configuration and a new oversized neodymium 21" woofer, delivers both consistent low end as well as an amazing punch in the upper lows.*

21" long excursion neodymium woofers with 5.3" voice coil

**Ethernet connectivity**

**Built-in DSP – Presets • Cardioid preset included**

Frequency Response: 28 Hz - 120 Hz

Maximum SPL: 133 dB

Dimensions (HxWxD): 668 x 749 x 900 mm

Weight: 75.8 kg



# LINE ARRAY

## X208

*Style and performance come together in the X208. Exclusive, customized waveguide projects sound with consistency at great distance, allowing you to handle nearly any application. Amate Audio technology in X208 delivers ease of use a unique sound quality in a compact size. Innovation that you can hear!*



**Rear view of 4 units set**  
(1x X208A + 3x X208P)

## X208A



**Retail**

4,180 €

**2x 8" ACTIVE SYSTEM, BI-AMPLIFIED, 48 bit - 96 kHz DSP**

2400 W Low, 600 W Mid/High

**Ethernet connectivity**

**Built-in DSP – Presets**

Speakon output to drive up to 3 units X208P.

Directivity: 110° x 11°

2x 8" Neodymium Woofers (2.5" voice coil)

2x 1.7" PEN diaphragm neodymium drivers

Frequency response: 78 Hz - 18 kHz

Maximum SPL: 130 dB (one unit)

Dimensions (HxWxD): 250 x 684 x 522 mm • Weight: 25 kg

## X208P

**PASSIVE UNIT**

Same acoustic features as X208A.

Weight: 22 kg

**Retail**

1,940 €



# X210



*There is no way to make the X210 any better. Breakthrough technologies, cutting-edge acoustic design, the highest quality, precision-engineered, customised components and materials – X210 is the flagship of the Xcellence series and the epitome of audio perfection. What are you waiting for?...*



Rear view of 2 units set (Active + Passive)



**DSP STUDIO®  
CONTROL  
SOFTWARE**  
iPad App version  
available

# X210A



**Retail**

5,110 €

**2x 10" ACTIVE SYSTEM, BI-AMPLIFIED, 48 bit - 96 kHz DSP**  
2400 W Low, 600 W Mid/High.

**Ethernet connectivity**

**Built-in DSP – Presets**

Speakon output to drive one X210P

Directivity: 120° x 7°

2x 10" Neodymium woofers (2.5" voice coil)

3x 1.7" PEN diaphragm neodymium drivers

Frequency response: 70 Hz - 18 kHz.

Maximum SPL: 134 dB (one unit)

Dimensions (HxWxD): 314 x 764 x 574 mm • Weight: 37 kg

# X210P

**PASSIVE UNIT**

Same acoustic features as X210A.  
Weight: 33 kg

**Retail**

2,735 €

# XCELLENCE CONFIGURATIONS

## STAGE MONITOR



X14T

## POINT SOURCE



X14T / X15T

## POLE MOUNT

X14T + X18T  
X15T + X18T

## STACKING



4x X208 + X18T + FR-X18



2x X210 + X215W + ST-X215



2x X210 + X218W3K + FR-X210



4x X210 + 2x X21T + FR-X210

*A high-end range  
never before was  
so easy to install!*

Every little aspect of Xcellence series has been designed for maximum user comfort, safety and ease of installation. Shapes, details, finishes, stainless-steel resistant materials, all together allow Xcellence configurations make the most of every system.



# Suitable in any application

## FLYING



8x X208 + TA-X208R



4x X208 + X215W + TA-X210R + FA-X208/215



2x X210 + 2x X208 + TA-X210R + FA-X208/210



8x X210 + TA-X210R



4x X208 + X18T + TA-X208R + KR-18T



X14T / X15T + HR1215 + GT50HR



X14T / X15T + HR1215

## WALL MOUNT



X14T / X15T + UB-L

# DSP STUDIO CONTROL SOFTWARE



## ENJOYABLE FROM THE BEGINNING

Straightforward, modern and user-friendly interface. Never before was so nice to setup a system.

Effortless auto-detection that let you add intuitively each cabinet into a layout before adjusting its position.

## INTUITIVE ORGANIZATION

Organize and control several cabinets quickly and easily. Links for two or more identical cabinets, or as groups of varying models.

Optimized layout grid for any project size.

## GET FULL CONTROL

Comprehensive information about input and output levels, heat-sink temperature, clip and protection indicators.

Edit until the finest detail of parameters such as crossover frequency, gain, limiter, polarity, delay, five custom parametric EQs or an array of filter shapes.

## FLEXIBILITY LIKE NEVER BEFORE

Bespoke control protocol that supports Wi-Fi connectivity (control over IP). CWK-D wireless communication kit needed.

Edit processor values easily from any spot in the venue.

*Fcellence*

# "Instant access to outstanding sound"

1

Configure your wifi network

2

Detect loudspeakers

3

Setup audio settings

4

Enjoy the best sound



Link setup



Equalizer setup



Audio settings controls



Loudspeaker information



DSP Studio 2  
Download it from our website:  
[www.amateaudio.com](http://www.amateaudio.com)



Auto detection

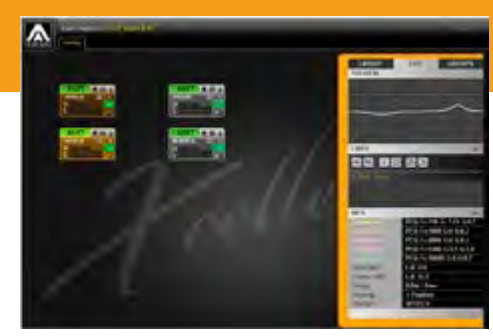

Link edition



Preset selection



Advanced parameters setup

# PRICE LIST

2016



---

## **Amate Audio S.L.**

Perpinyà, 25 · Polígon Industrial Nord · 08226 Terrassa  
T. +34 93 735 65 65 – F. +34 93 735 60 48 – [export@amateaudio.com](mailto:export@amateaudio.com)

**R+D / FACTORY:** Violinista Vellsolà, 18 · 08222 Terrassa  
T. +34 93 736 23 90 – F. +34 93 786 47 00

**Barcelona – SPAIN**

---

[www.amateaudio.com](http://www.amateaudio.com)

All pictures and specifications on this price list are related for quick reference only. Refer to the main catalogue for more accurate information.

All prices are ex VAT.

Due to the continuous research and development of our R&D, the product specifications are subject to change without prior notice.